

Parallel Arm Rotary Cutter

RCP2660, RCPM2660, RCP3060 and RCPM3060

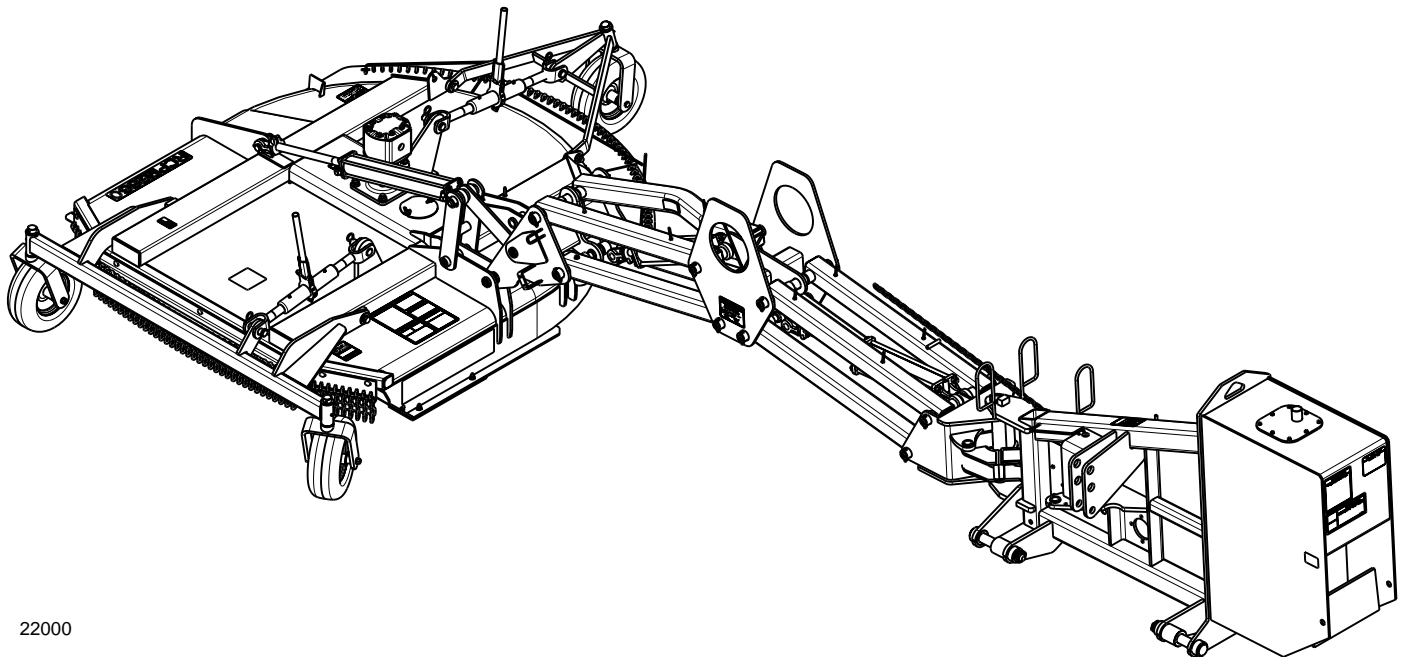

22000

316-111M Operator's Manual



Read the Operator's manual entirely. When you see this symbol, the subsequent instructions and warnings are serious - follow without exception. Your life and the lives of others depend on it!

© Copyright 2008 Printed 12/16/08

*Hydraulic hoses and fittings (not shown) are included with Parallel Arm Cutter.
Cover photo may show optional equipment not supplied with standard unit.*



Important Safety Information	1	Section 3: Operating Procedures	27
Safety at All Times	1	Operating Check List	27
Look For The Safety Alert Symbol	1	Transporting	27
Safety Labels	4	Cutting Operation	28
Introduction	10	Breakaway Operating Procedures	29
Application	10	Cylinder Shear Bolt	29
Using This Manual	10	General Operating Instructions	30
Owner Assistance	10	Section 4: Optional Equipment	31
Section 1: Assembly & Set-up	12	Hydraulic Control Options	31
Tractor Requirements	12	Operator Protective Shield Option	31
Horsepower	12	Section 5: Hydraulic Plumbing	32
Weight	12	Hydraulic Plumbing Without Solenoid	32
Wheel Base	12	Hydraulic Plumbing With Solenoid	32
Hitch	13	Wiring Schematic (Without Float Switch)	33
Hydraulic Outlets	13	Wiring Schematic (With Float Switch)	34
PTO Speed	13	Pump & Motor Plumbing	35
Protective Equipment	13	Breakaway Cylinder Plumbing	36
Dealer Preparations	13	Pressure Shut Down Valve Operation	36
3-Point Hook-up	14	Section 6: Maintenance & Lubrication	37
PTO Hook-up	15	Maintenance	37
Flow Control Valve Plumbing	16	Cutter Blades	37
Tractors Rated at 15 GPM and Under	16	Skid Shoes	38
Tractors Rated at 16 GPM and Above	16	Solenoid Valve Block	39
Fill Hydraulic Reservoir	16	Tractor Maintenance	39
Hydraulic Hose Hook-up	17	Cutter Storage	39
Solenoid Controlled Cylinders	17	Lubrication Points	40
Tractor Controlled Cylinders	18	Parallel Arm	40
Breakaway Cylinder	18	Deck Pivot	40
Electrical Hook-up	19	Driveline Profile	40
Switch Functions	19	PTO U-joint	41
Operational Checks	20	Gauge Wheel	41
Transport Safety Chain	20	Ratchet Jack	41
Momentary Push Button Switches	21	Motor Spindle Hub	42
Float Switch Control	21	Hydraulic Reservoir	42
Tractor Console Control Levers	22	Speed Increaser	42
Pump & Motor Operation	23	Section 7: Specifications & Capacities	43
Gauge Wheel Model Set-up	24	Section 8: Features & Benefits	45
Section 2: Adjustments	25	Section 9: Troubleshooting	46
Hydraulic Flow Control Settings	25	Section 10: Appendix	48
Cutter Flow Control	25	Torque Values Chart	48
Tractor Flow Control	25	Warranty	49
Deck Level Adjustments	26		
Cutter Without Gauge Wheels	26		
Cutter With Gauge Wheels	26		

© Copyright 2008 All rights Reserved

Land Pride provides this publication "as is" without warranty of any kind, either expressed or implied. While every precaution has been taken in the preparation of this manual, Land Pride assumes no responsibility for errors or omissions. Neither is any liability assumed for damages resulting from the use of the information contained herein. Land Pride reserves the right to revise and improve its products as it sees fit. This publication describes the state of this product at the time of its publication, and may not reflect the product in the future.

Land Pride is a registered trademark.

All other brands and product names are trademarks or registered trademarks of their respective holders.

Printed in the United States of America.

Important Safety Information

These are common practices that may or may not be applicable to the products described in this manual.

Safety at All Times

Thoroughly read and understand the instructions given in this manual before operation. Refer to the "Safety Label" section, read all instructions noted on them.

Do not allow anyone to operate this equipment who has not fully read and comprehended this manual and who has not been properly trained in the safe operation of the equipment.

- ▲ Operator should be familiar with all functions of the unit.
- ▲ Operate implement from the driver's seat only.
- ▲ Make sure all guards and shields are in place and secured before operating implement.
- ▲ Do not leave tractor or implement unattended with engine running.
- ▲ Dismounting from a moving tractor could cause serious injury or death.
- ▲ Do not allow anyone to stand between the tractor and implement while backing up to the implement.
- ▲ Keep hands, feet, and clothing away from power-driven parts.
- ▲ Wear snug fitting clothing to avoid entanglement with moving parts.
- ▲ Watch out for wires, trees, etc., when raising implement. Make sure all persons are clear of working area.
- ▲ Turning tractor too tight may cause implement to ride up on wheels. This could result in injury or equipment damage.
- ▲ Do not carry passengers on implement at any time.

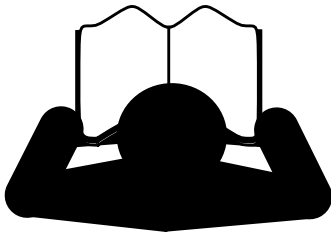

Look For The Safety Alert Symbol

The SAFETY ALERT SYMBOL indicates there is a potential hazard to personal safety involved and extra safety precaution must be taken. When you see this symbol, be alert and carefully read the message that follows it. In addition to design and configuration of equipment, hazard control and accident prevention are dependent upon the awareness, concern, prudence and proper training of personnel involved in the operation, transport, maintenance and storage of equipment.

Be Aware of Signal Words

A Signal word designates a degree or level of hazard seriousness. The signal words are:

DANGER

Indicates an imminently hazardous situation which, if not avoided, will result in death or serious injury. This signal word is limited to the most extreme situations, typically for machine components that, for functional purposes, cannot be guarded.

WARNING

Indicates a potentially hazardous situation which, if not avoided, could result in death or serious injury, and includes hazards that are exposed when guards are removed. It may also be used to alert against unsafe practices.

CAUTION

Indicates a potentially hazardous situation which, if not avoided, may result in minor or moderate injury. It may also be used to alert against unsafe practices.

For Your Protection

- ▲ Thoroughly read and understand the "Safety Label" section, read all instructions noted on them.

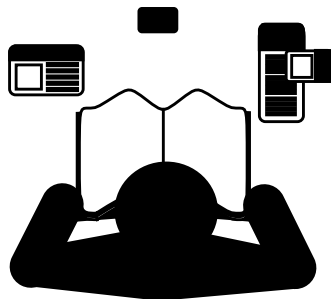

Shutdown and Storage

- ▲ Lower machine to ground, put tractor in park, turn off engine, and remove the key.
- ▲ Detach and store implements in a area where children normally do not play. Secure implement by using blocks and supports.

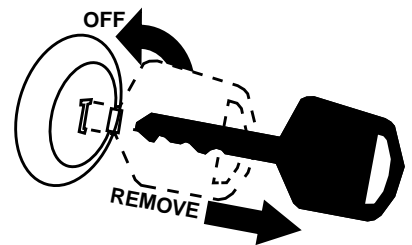

Important Safety Information

These are common practices that may or may not be applicable to the products described in this manual.

Use Safety Lights and Devices

- ▲ Slow moving tractors, self-propelled equipment, and towed implements can create a hazard when driven on public roads. They are difficult to see, especially at night.
- ▲ Flashing warning lights and turn signals are recommended whenever driving on public roads.

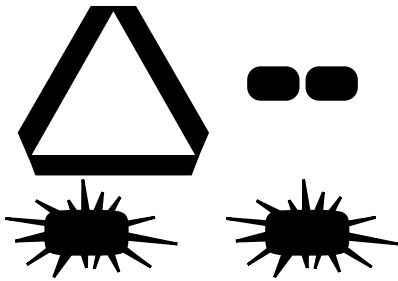

Transport Machinery Safely

- ▲ Comply with state and local laws.
- ▲ Maximum transport speed for implement is 20 mph. **DO NOT EXCEED.** Never travel at a speed which does not allow adequate control of steering and stopping. Some rough terrain require a slower speed.
- ▲ Sudden braking can cause a towed load to swerve and upset. Reduce speed if towed load is not equipped with brakes.

- ▲ Use the following maximum speed - tow load weight ratios as a guideline:
 - 20 mph** when weight is less than or equal to the weight of tractor.
 - 10 mph** when weight is double the weight of tractor.
- IMPORTANT:** Do not tow a load that is more than double the weight of tractor.

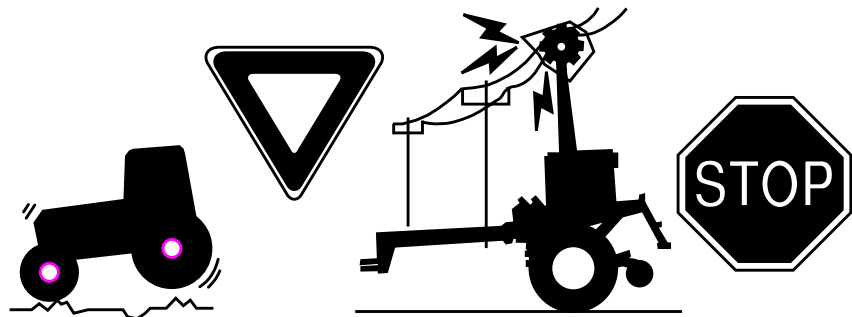

Use A Safety Chain

- ▲ A safety chain will help control drawn machinery should it separate from the tractor drawbar.
- ▲ Use a chain with the strength rating equal to or greater than the gross weight of the towed machinery.
- ▲ Attach the chain to the tractor drawbar support or other specified anchor location. Allow only enough slack in the chain to permit turning.
- ▲ Do not use safety chain for towing.

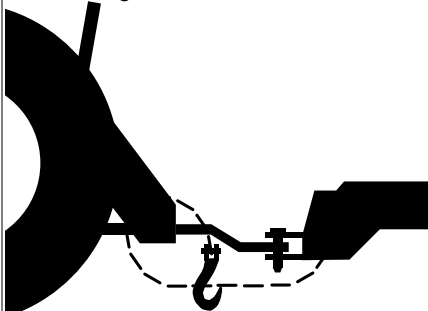

Practice Safe Maintenance

- ▲ Understand procedure before doing work. Use proper tools and equipment, refer to Operator's Manual for additional information.
- ▲ Work in a clean dry area.
- ▲ Lower the implement to the ground, put tractor in park, turn off engine, and remove key before performing maintenance.

- ▲ Allow implement to cool completely.
- ▲ Do not grease or oil implement while it is in operation.
- ▲ Inspect all parts. Make sure parts are in good condition & installed properly.
- ▲ Remove buildup of grease, oil or debris.
- ▲ Remove all tools and unused parts from implement before operation.



Important Safety Information

These are common practices that may or may not be applicable to the products described in this manual.

Prepare for Emergencies

- ▲ Be prepared if a fire starts.
- ▲ Keep a first aid kit and fire extinguisher handy.
- ▲ Keep emergency numbers for doctor, ambulance, hospital and fire department near phone.

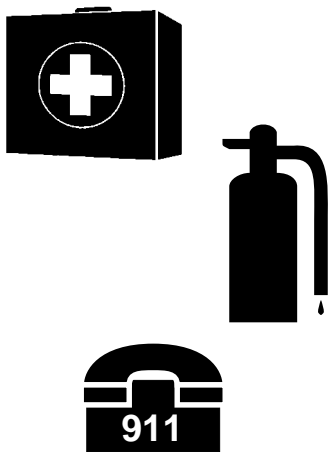
**Avoid High Pressure Fluids Hazard**

- ▲ Escaping fluid under pressure can penetrate the skin causing serious injury.
- ▲ Avoid the hazard by relieving pressure before disconnecting hydraulic lines or performing work on the system.
- ▲ Make sure all hydraulic fluid connections are tight and all hydraulic hoses and lines are in good condition before applying pressure to the system.
- ▲ Use a piece of paper or cardboard, NOT BODY PARTS, to check for suspected leaks.
- ▲ Wear protective gloves and safety glasses or goggles when working with hydraulic systems.
- ▲ If an accident occurs, see a doctor immediately. Any fluid injected into the skin must be treated within a few hours or gangrene may result.

**Keep Riders Off Machinery**

- ▲ Riders obstruct the operator's view, they could be struck by foreign objects or thrown from the machine.
- ▲ Never allow children to operate equipment.

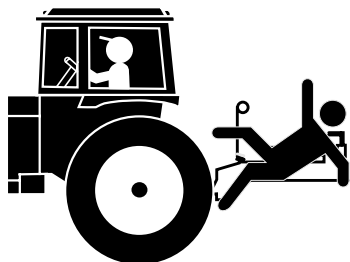
**Wear Protective Equipment**

- ▲ Protective clothing and equipment should be worn.
- ▲ Wear clothing and equipment appropriate for the job. Avoid loose fitting clothing.
- ▲ Prolonged exposure to loud noise can cause hearing impairment or hearing loss. Wear suitable hearing protection such as earmuffs or earplugs.
- ▲ Operating equipment safely requires the full attention of the operator. Avoid wearing radio headphones while operating machinery.



Important Safety Information

Safety Labels

1. Your Rotary Cutter comes equipped with all safety labels in place. They were designed to help you safely operate your implement. Read and follow their directions.
2. Keep all safety labels clean and legible.
3. Replace all damaged or missing labels. To order new labels go to your Land Pride dealer.
4. Some new equipment installed during repair requires safety labels to be affixed to the replaced component as specified by Land Pride. When ordering new components make sure

the correct safety labels are included in the request. To order new labels go to your Land Pride dealer.

5. Refer to this section for proper label placement.

To install new labels:

- a. Clean the area the label is to be placed.
- b. Spray soapy water on the surface where the label is to be placed.
- c. Peel backing from label. Press firmly onto the surface.
- d. Squeeze out air bubbles with the edge of a credit card.

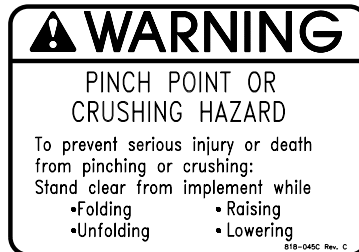
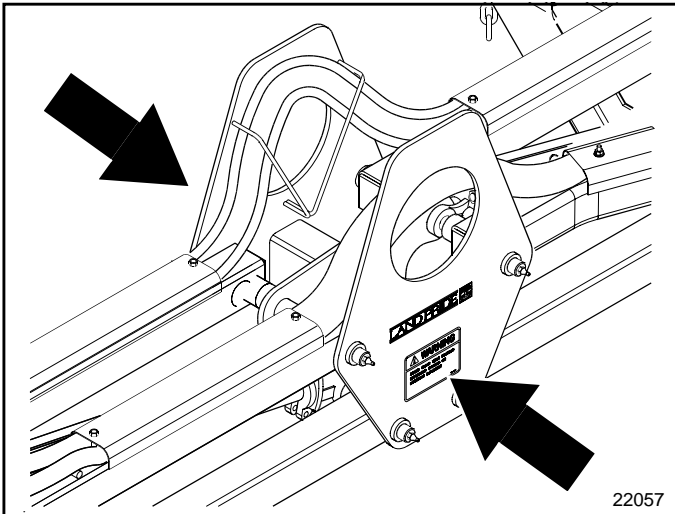

818-045C

Warning - Pinch Point Hazard
2-Places

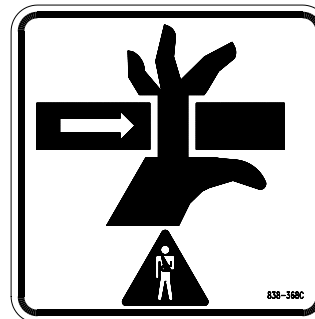
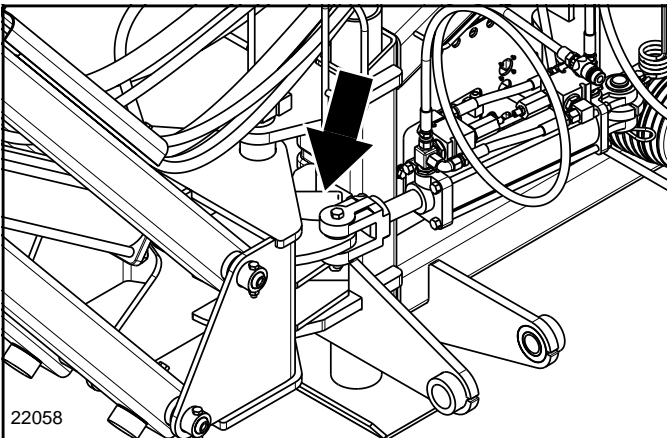

838-368C

Warning - Pinch Point Hazard

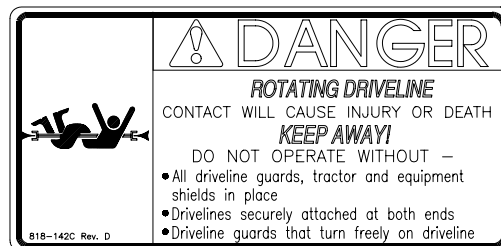
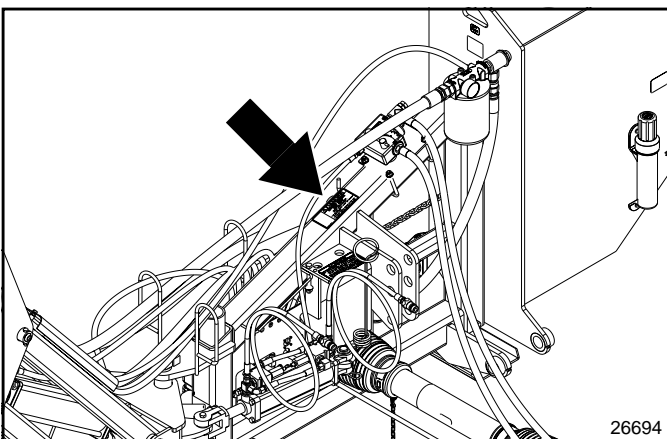

818-142C

Danger - Rotating Driveline Hazard

Important Safety Information

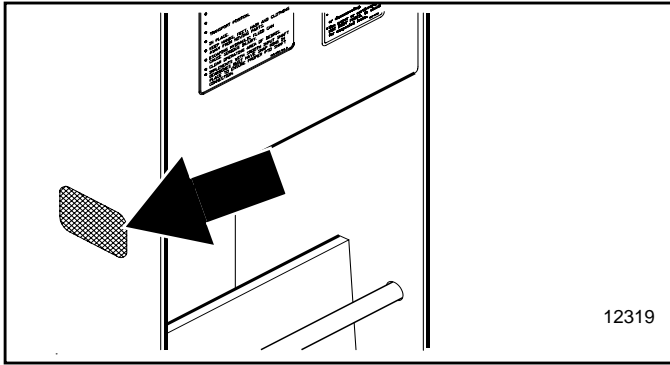

12319



818-229C
Amber Reflector

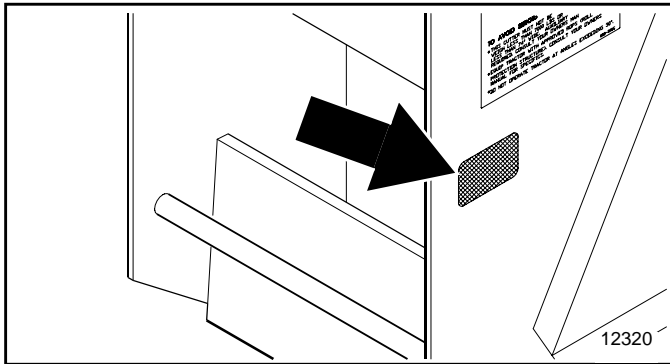

12320



818-230C
Red Reflector

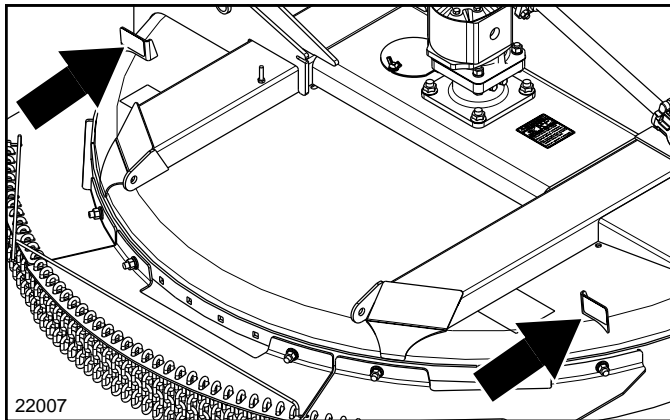

22007



818-230C
Red Reflector (2 places)

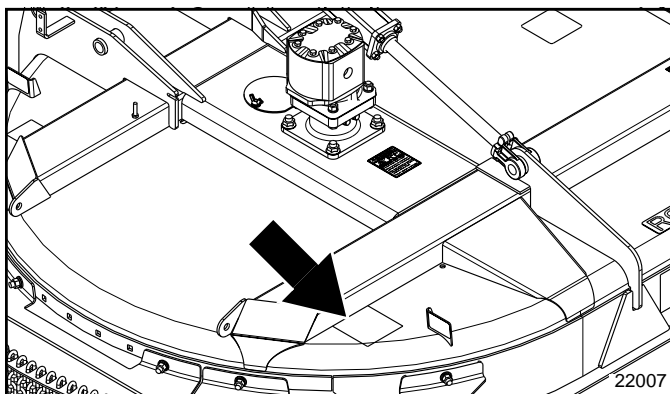

22007

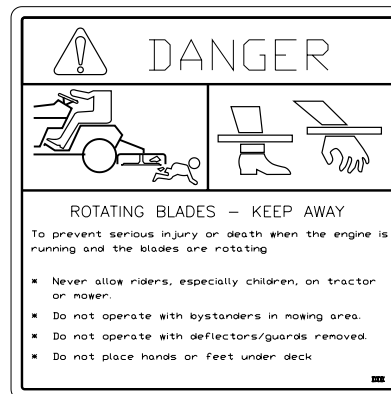

818-564C
Danger - Keep Away
Rotating Blade Hazard

Important Safety Information

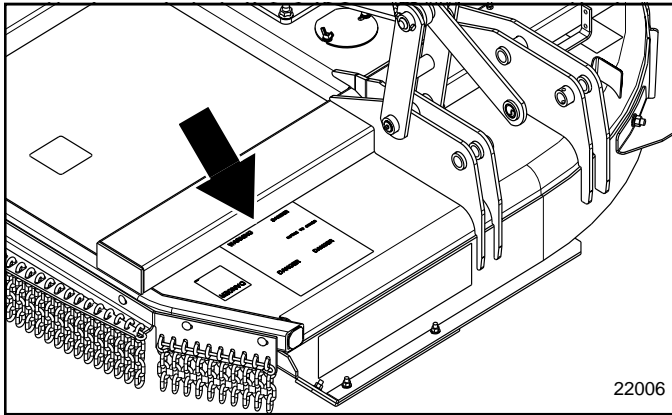

WARNING

To prevent serious injury or death:

- Read and understand Operator's Manual before using. Review annually.
- Do not permit riders on the tractor or mower. Never carry children on tractor seat.
- Do not allow children to operate mower.
- Operate only with guards installed and in good condition.
- Keep away from moving parts.
- Operate only with tractor equipped with RDPS and seatbelts.
- Before mowing, clear debris from mowing area.
- Do not operate in the raised position.
- Stop engine, set brake and wait for all moving parts to stop before dismounting.
- Support mower securely before working beneath unit.
- Transport with clean reflectors, SMV and working lights as required by federal, state, and local laws.

Si no lee ingles, pida ayuda a alguien que si lo lee para que le traduzca las medidas de seguridad.

DANGER

KEEP HANDS AND FEET AWAY

NOTICE TO OWNER

An OPERATOR'S MANUAL was attached to this implement during final inspection at the factory. If it was not attached at the time of purchase, please contact your selling dealer at once.

- Read and understand Manual BEFORE operating the implement.
- Pay attention to the safety messages.

DANGER

ROTATING BLADES - KEEP AWAY

To prevent serious injury or death when the engine is running and the blades are rotating:

- Never allow riders, especially children, on tractor or mower.
- Do not operate with bystanders in mowing area.
- Do not operate with deflectors/guards removed.
- Do not place hands or feet under deck.

DANGER

THROWN OBJECT HAZARD

To prevent serious injury or death:

- Do not operate unless all guards are installed and in good condition.
- Stop blade rotation if by standards come within several hundred feet.

818-830C

818-830C

Warning/Danger/Notice - Combination Safety Decal

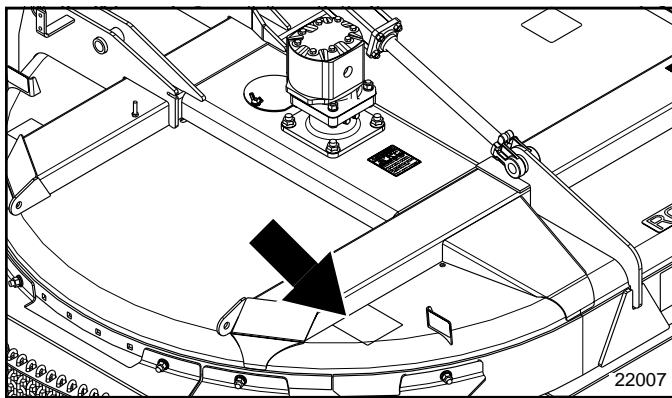

DANGER

ROTATING BLADES - KEEP AWAY

To prevent serious injury or death when the engine is running and the blades are rotating:

- Never allow riders, especially children, on tractor or mower.
- Do not operate with bystanders in mowing area.
- Do not operate with deflectors/guards removed.
- Do not place hands or feet under deck.

818-564C

Danger - Keep Away Rotating Blade Hazard

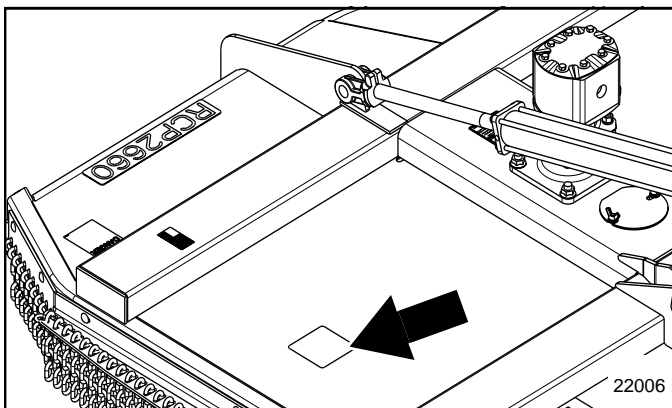

DANGER

ROTATING BLADES-KEEP AWAY

To prevent serious injury or death from rotating blade contact:

- Never allow riders, especially children, on tractor.
- Do not operate with bystanders in mowing area.
- Do not operate with deflectors/guards removed.
- Do not place hands or feet under deck when operating or when engine is running.

818-555C

818-555C

Danger - Rotating Blades Keep Away

Important Safety Information

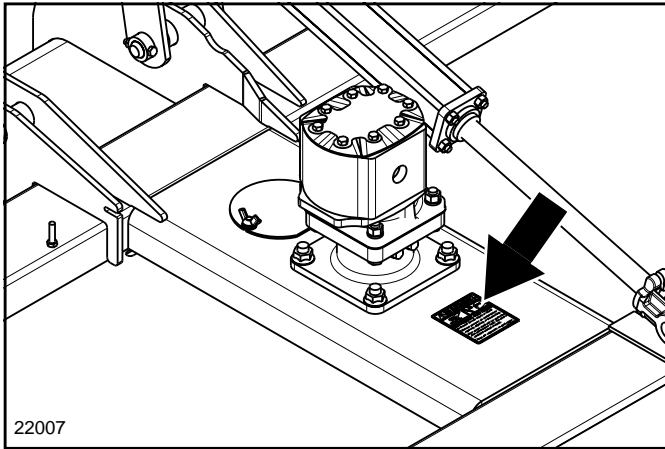

818-339C
Warning - High Pressure Fluid Hazard

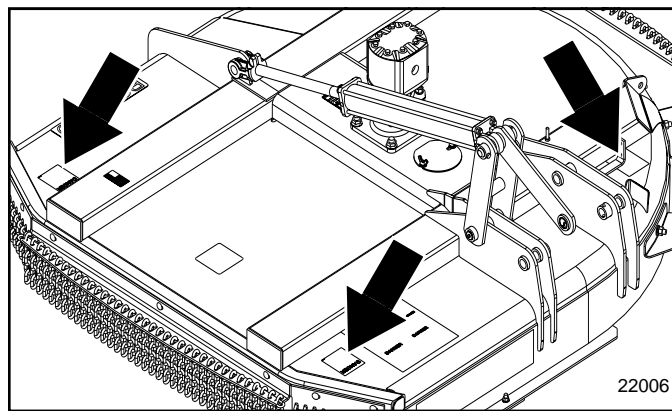

818-556C
Danger - Thrown Object Hazard (3-Places)

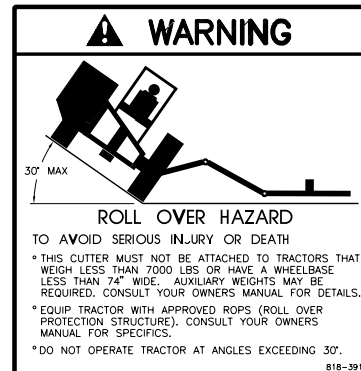
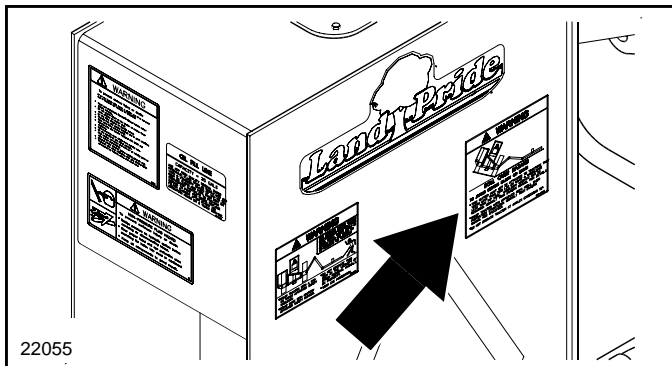

818-391C
Warning - Tractor Roll Over Hazard

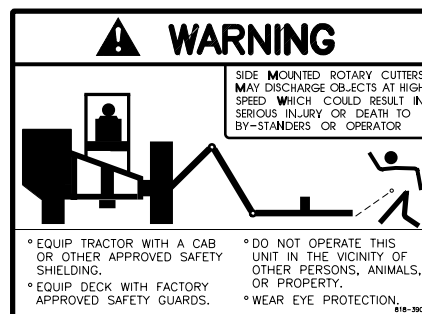
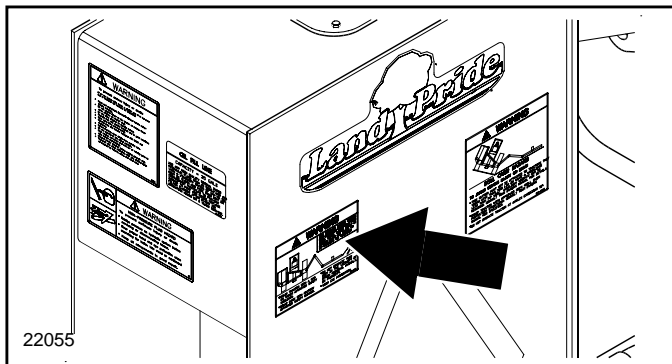

818-390C
Warning - Thrown Object Hazard

Important Safety Information

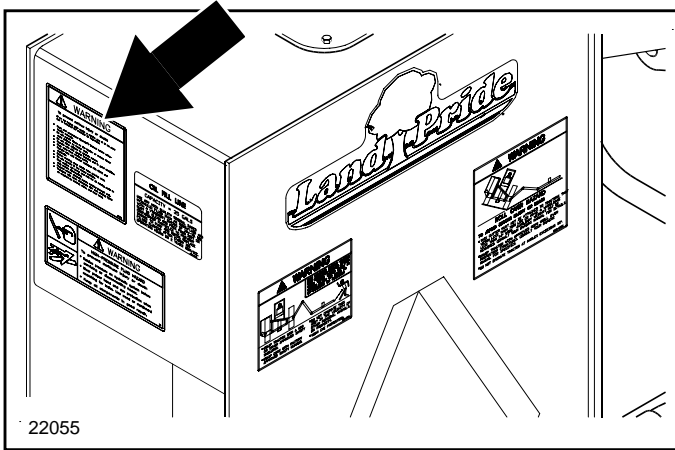

! WARNING	
To prevent serious injury or death:	
<ul style="list-style-type: none"> * Read and understand Operator's Manual before using. Review annually. * Do not permit riders on the tractor or mower. Never carry children on tractor seat. * Do not allow children to operate mower. * Operate only with guards installed and in good condition. * Keep away from moving parts. * Operate only with tractor equipped with ROPS and seatbelts. * Before mowing, clear debris from mowing area. * Do not operate in the raised position. * Stop engine, set brake and wait for all moving parts to stop before dismounting. * Support mower securely before working beneath unit. * Transport with clean reflectors, SMV and working lights as required by federal, state, and local laws. 	
Si no lee ingles, pida ayuda a alguien que si lo lea para que le traduzca las medidas de seguridad.	
818-554C	

818-554C

Caution - General Safety Information

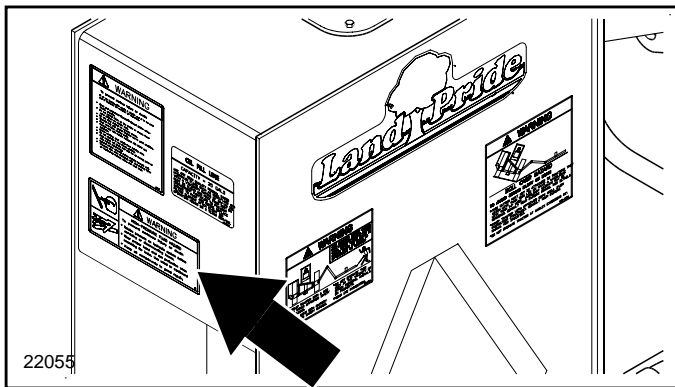

	! WARNING	
	<p style="text-align: center;">HIGH-PRESSURE FLUID HAZARD</p> <p>To prevent serious injury or death</p> <ul style="list-style-type: none"> * Relieve pressure on hydraulic system before servicing or disconnecting hoses. * Wear proper hand and eye protection when searching for leaks. Use wood or cardboard * Keep all components in good repair. 	
	15	

818-831C

Warning - High Pressure Fluid Hazard

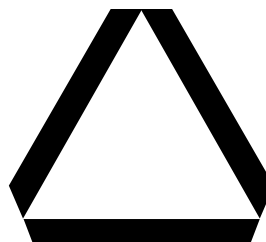
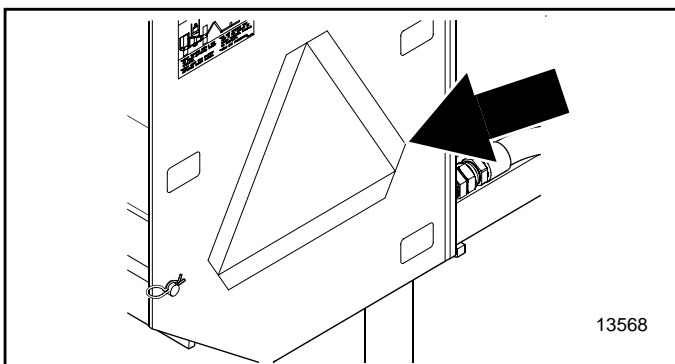

818-003C

Slow Moving Vehicle Emblem

Important Safety Information

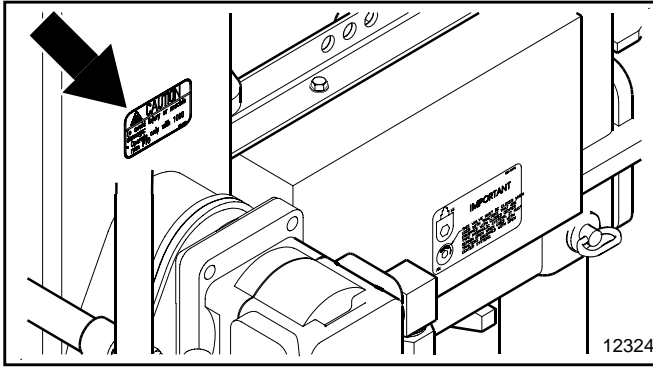

CAUTION

To avoid drive system component damage:

- Operate only with 540 rpm PTO

818-403C Rev. A

818-403C

(Used only on RCP2660 & RCP3060 Series)
Caution - Operate only with 540 rpm PTO

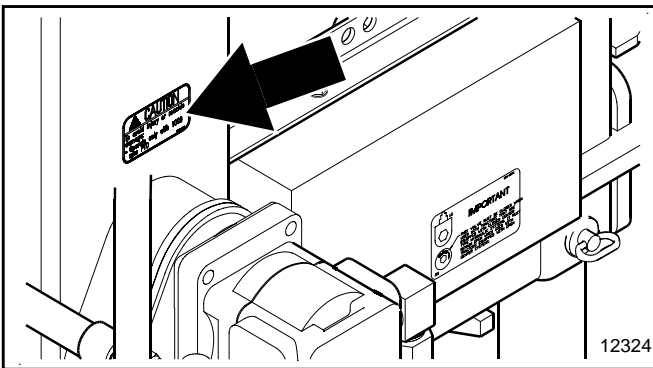

IMPORTANT

To avoid unsatisfactory or uneven cutting:

- Operate only with 1000 rpm PTO

818-484C

818-484C

(Used only on RCPM2660 & RCPM3060 Series)
Important - Operate only with 1000 rpm PTO

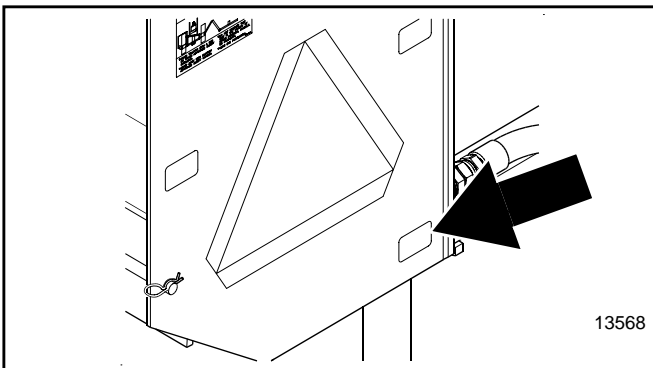

IMPORTANT

THIS VALVE MUST BE OPEN DURING CUTTER OPERATION OR PUMP DAMAGE WILL OCCUR.

OPEN CLOSE

818-388C

Important - Valve must be open

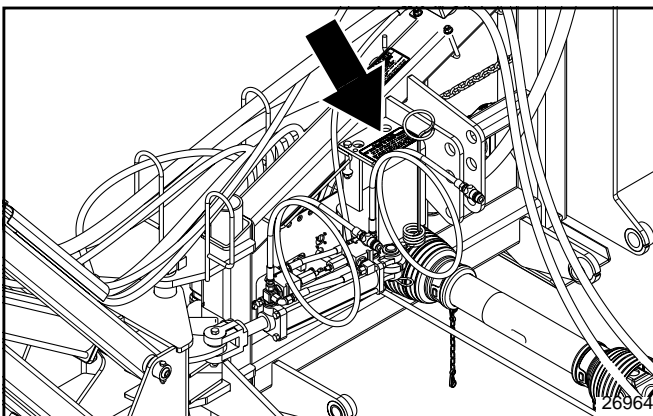

CAUTION

To Avoid Injury Or Machine Damage

- Use only specified shear bolt for breakaway.
- Do not alter cartridge valves on breakaway.

Shear bolt P/N 802-885C (7/16 x 3 1/2 Grade 8)
Any alterations to shear bolt and/or cartridge valves for breakaway will deem warranty null and void on any areas affected by such action.

848-369C

848-369C

Caution: Avoid Injury or Machine Damage

Introduction

Land Pride welcomes you to the growing family of new product owners.

This Rotary Cutter has been designed with care and built by skilled workers using quality materials. Proper assembly, maintenance and safe operating practices will help you get years of satisfactory use from the machine.

Application

The Hydraulic Parallel Arm Rotary Cutters are designed and built by Land Pride to provide excellent cutting performance on ditch banks and other sloping areas adjacent to right-of-ways, lakes, ponds and streams. They are designed to work equally as well in and around areas of restricted access such as over or under fences, guardrails, low overhanging branches, tree limbs and hedges. These units perform extremely well in tall grass cutting applications and will easily cut through standing brush up to two inches in diameter. An optional cutter head equipped with two forward and one rear gauge wheel is also available for customers who want to maintain a constant cutting height with minimal control lever manipulation.

The RCP2660 and RCPM2660 cutters are adapted for Category 2 or 3 three-point hitch mounting on 75 hp. to 150 hp. tractors weighing 8,000 lbs. or more.

The RCP3060 and RCPM3060 cutters are adapted for Category 2 or 3 three-point hitch mounting on 95 hp. to 175 hp. tractors weighing 12,000 lbs. or more.

The Hydraulic drive requires 540 rpm input PTO speed for RCP2660 & RCP3060 models and 1000 rpm for RCPM2660 & RCPM3060 models. Depending upon hydraulic configuration, two or four duplex hydraulic outlets are required on the tractor to operate the cutter's parallel arms and deck angle.

See "**Section 7: Specifications & Capacities**" on page 43 and "**Section 8: Features & Benefits**" on page 45 for additional information and performance enhancing options.

Using This Manual

- This Operator's Manual is designed to help familiarize you with safety, assembly, operation, adjustments, troubleshooting, and maintenance. Read this manual and follow the recommendations to help ensure safe and efficient operation.
- The information contained within this manual was current at the time of printing. Some parts may change slightly to assure you of the best performance.
- To order a new Operator's or Parts Manual contact your authorized dealer. Manuals can also be downloaded, free-of-charge from our website at www.landpride.com.

Terminology

"Right" or "Left" as used in this manual is determined by facing the direction the machine will operate while in use unless otherwise stated.

Definitions

NOTE: A special point of information that the operator must be aware of before continuing.

IMPORTANT: A special point of information related to its preceding topic. Land Pride's intention is that this information should be read and noted before continuing.

Owner Assistance

The Warranty Registration card should be filled out by the dealer at the time of purchase. This information is necessary to provide you with quality customer service.

If customer service or repair parts are required contact a Land Pride dealer. A dealer has trained personnel, repair parts and equipment needed to service the cutter.

The parts on your cutter have been specially designed and should only be replaced with genuine Land Pride parts. Therefore, should your cutter require replacement parts go to your Land Pride Dealer.

Serial Number Plate

For prompt service always use the serial number and model number when ordering parts from your Land Pride dealer. Be sure to include your serial and model numbers in correspondence also. Refer to Figure 1: for the location of your serial number plate.

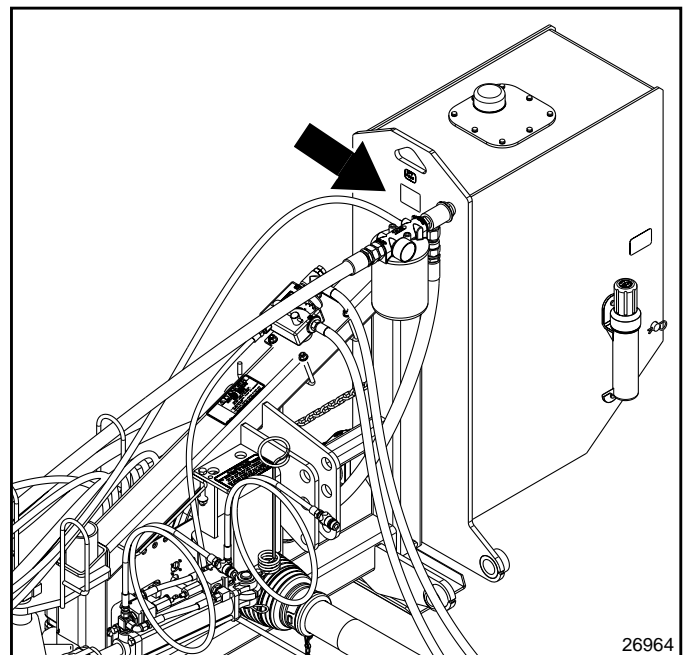

Serial Number Plate Location
Figure 1

Introduction

Further Assistance

Your dealer wants you to be satisfied with your new cutter. If for any reason you do not understand any part of this manual or are not satisfied with the service received, the following actions are suggested:

1. Discuss the matter with your dealership service manager making sure he is aware of any problems you may have and that he has had the opportunity to assist you.
2. If you are still not satisfied, seek out the owner or general manager of the dealership, explain the problem and request assistance.
3. For further assistance write to:

Land Pride Service Department
1525 East North Street
P.O. Box 5060
Salina, Ks. 67402-5060
E-mail address
lpservicedept@landpride.com

Section 1: Assembly & Set-up

Tractor Requirements

Horsepower

Tractor horsepower must be capable of controlling the Parallel Arm Rotary Cutter under all operating conditions. Smaller tractors must not be used.

RCP2660 & RCPM2660

Horsepower Range75-150 HP

RCP3060 & RCPM3060

Horsepower Range95-175 HP

Weight

Tractor weight must be sufficient to control the Parallel Arm Rotary Cutter under all operating conditions. Tractors not meeting the absolute minimum weight listed below must not be used.

A right hand overturning torque load is present on the tractor when parallel arms are fully extended. Tractors will need auxiliary counterbalance weights added if the tractor's total weight is less than the basic minimum weight listed below.

RCP2660 & RCPM2660

Tractor absolute minimum weight 8,000 lbs.

Tractor basic minimum weight. 8,500 lbs.

RCP3060 & RCPM3060

Tractor absolute minimum weight 12,000 lbs.

Tractor basic minimum weight. 13,500 lbs.

It is best to add auxiliary weights to the left rear tractor wheel. In addition, up to eight 100 lb. suitcase type weights can be added to the weight bracket on the hydraulic reservoir. However, adding weights to the reservoir can lighten the tractor's front end.

IMPORTANT: Front tractor weights and/or ballast to tires may be required to offset weight of cutter and auxiliary weights. Consult your tractor manual to determine if additional ballast is needed.

IMPORTANT: Extended parallel arms will pull the tractor's front to the right. When necessary, add weight to the tractor front to stabilize it. Consult your tractor's manual for allowable added weights.

IMPORTANT: The tractor's right rear wheel should be pressurized to the manufactures highest recommended air pressure.

Wheel Base

Refer to Figure 1-1 & Figure 1-2:

Rear wheel base must meet minimum requirements when measured from outside face to outside face of rear tractor tires. Smaller wheel bases must not be used.

RCP2660 & RCPM2660

Rear Wheel Base74" minimum

RCP3060 & RCPM3060

Rear Wheel Base95" minimum

The deck motor may interfere with the right rear tractor tire when deck is folded for transporting. This is especially true if the outside face of the tire is more than 47" away from the tractor center. Tractors equipped with dual wheels may need the outside right rear wheel removed.

The RCP(M)3060 cutter requires a dual wheel on the left hand side or wheel weights equal to the weight of a dual wheel.

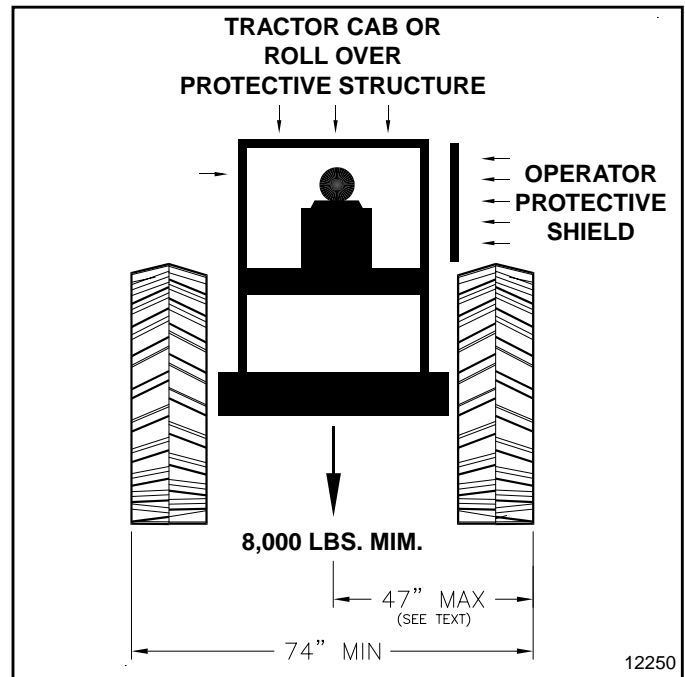

RCP2660 & RCPM2660 Minimum Tractor Requirements
Figure 1-1

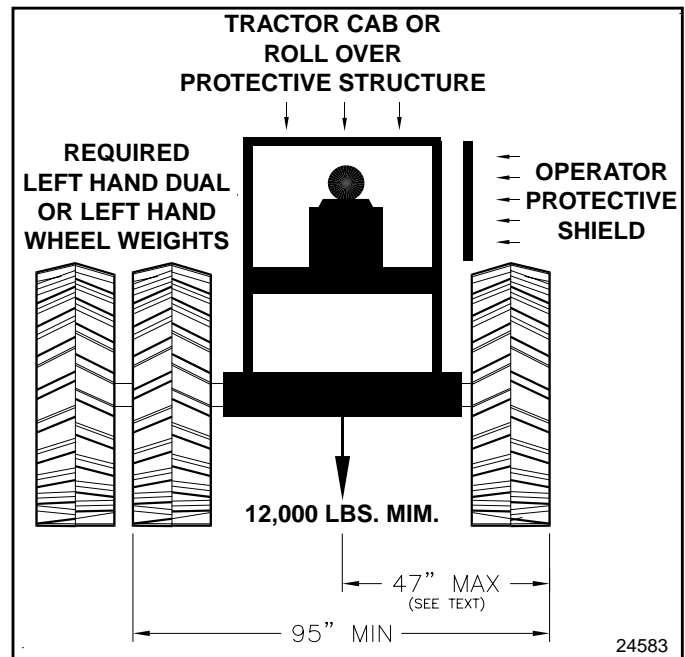

RCP3060 & RCPM3060 Minimum Tractor Requirements
Figure 1-2

Section 1: Assembly & Set-up

Hitch

A 3-Point Category II or Category III hitch is required. The lower 3-Point arms of the 3-Point hitch must be stabilized to prevent side-to-side movement. Most tractors have sway blocks or adjustable chains for this purpose.

Hydraulic Outlets

The number of tractor hydraulic duplex outlets required is dependent upon if the Rotary Cutter is set-up with solenoid controlled cylinders or tractor controlled cylinders.

Solenoid Controlled

- Two duplex outlets are required if parallel arms and deck cylinders are solenoid controlled with momentary push button switches at the control stick. Breakaway cylinder is controlled by tractor lever.

Tractor Controlled

- Four duplex outlets are required if parallel arms, deck and breakaway cylinders are all controlled by tractor levers.

PTO Speed

The RCP cutters requires 540 rpm Power Take-Off (PTO) speed and the RCPM cutter requires 1000 rpm PTO speed to operate the hydraulic pump & motor. Required tractor horsepower to operate the pump & motor is approximately 30 HP.

Protective Equipment

Refer to Figure 1-1:

The tractor **MUST** be equipped with protective equipment designed to shield the operator from thrown objects and tractor roll over. An enclosed tractor cab with a Roll Over Protective Structure (ROPS) may qualify. See tractor’s manual for type of protection your tractor has.

Tractors with only a ROPS must also have a protective shield added to the right hand fender. A universal operator protective shield is available from Land Pride. Refer to page 31 for additional information and installation.

It is also recommended that a protective shield or screen be added to the right hand side of the tractor engine cowling and radiator. This will help protect the tractor’s finish and radiator against thrown objects.

Dealer Preparations

This cutter has been assembled at the factory. However, some preparations will be necessary to attach the cutter to customer’s tractor.

- Make certain the intended tractor conforms to the “Tractor Requirements” on page 12.
- Review and check off **Preparation Checklist** below before proceeding.

Preparation Checklist	
<input type="checkbox"/>	Upper hitch pin is not Included with unit. Determine customer's tractor hitch type. (Cat II or Cat III). Buy required upper hitch pin locally or order a Land Pride hitch pin if customer's tractor does not included the pin. See Land Pride's upper hitch pin part numbers below. 805-079C - Upper Hitch Pin Cat II (1" dia. x 3 3/8" usable) 805-196C - Upper Hitch Pin Cat III (1 1/4" dia. x 3 3/8" usable)
<input type="checkbox"/>	Before operating this unit, 80-90 EP Gear Lube must be added to the gearbox & motor as indicated in the “Maintenance & Lubrication” section for “Speed Increaser” on page 42 of this manual.
<input type="checkbox"/>	35 Gallons of Hydraulic Fluid is needed for the hydraulic reservoir. Use any high quality mineral based hydraulic fluid such as Mobil Fluid 424 with a viscosity rating of 10W-30.
<input type="checkbox"/>	Additional hydraulic fluid (approx 2 gallons) for the tractor reservoir.
<input type="checkbox"/>	Miscellaneous assembly tools: hammer, tape measure, hacksaw, assortment of wrenches and sockets, 1/4” drill, drill bits and spirit level.
<input type="checkbox"/>	Quick disconnect adaptors that match tractor’s duplex outlets. Quantity required depends on option selected: (4) If equipped with solenoid control box. (8) If not equipped with hose hook-up.
<input type="checkbox"/>	Possible need for forklift or hoist capable of lifting 2500 lbs.
<input type="checkbox"/>	Auxiliary tractor weights (depending on tractor size). See “Tractor Requirements” on page 12.
<input type="checkbox"/>	A minimum of two people available during assembly.
<input type="checkbox"/>	If a pin, bolt or other part has been removed, and you are unsure where it is used, use the Parts Manual to identify it. Be sure the part gets used in the correct location. By double checking while you assemble, you will lessen the chance of using a bolt incorrectly that may be needed later.
<input type="checkbox"/>	Safety decals are legible and undamaged from shipment.
<input type="checkbox"/>	PTO driveline and loose parts bag/box shipped with the cutter are present.

Section 1: Assembly & Set-up

3-Point Hook-up

IMPORTANT: Hydraulic fluid must be added to the cutter hydraulic reservoir before operating the pump. Otherwise hydraulic pump will be damaged.

Prepare cutter as follows:

1. Be sure transport safety chain is hooked to the deck. See Figure 1-15 on page 20.
2. Position cutter on a flat level concrete surface.

Refer to Figure 1-3:

3. There are three hitch categories represented in Figure 1-3. Determine which category fits the tractor being used and arrange cutter hitch pins as shown for that category.

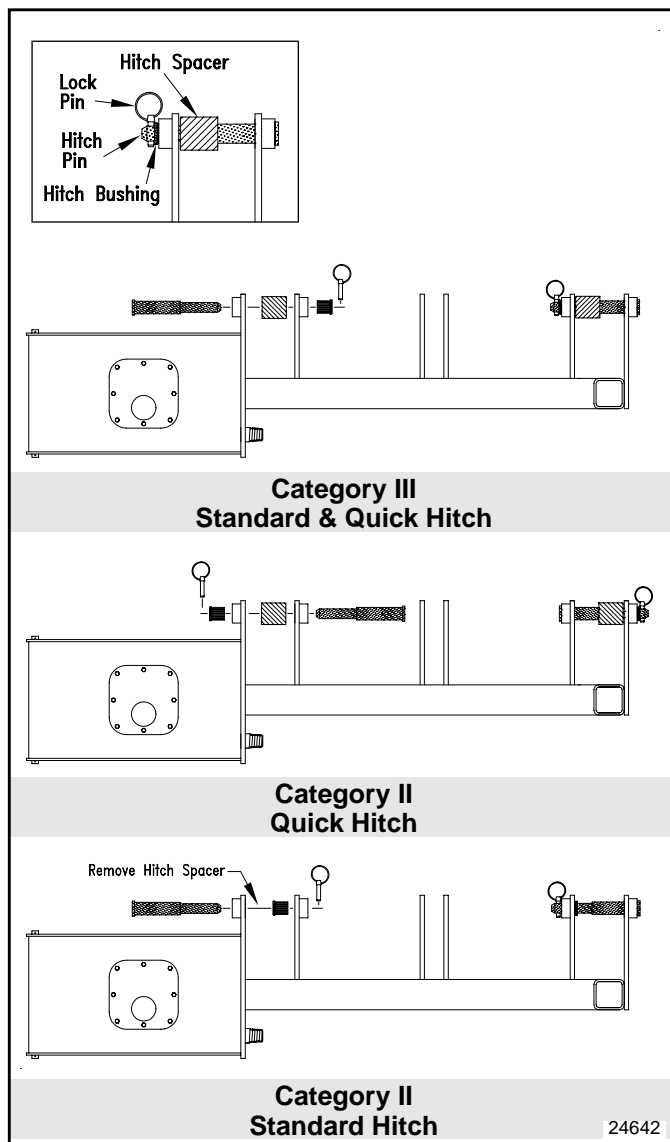

**Hitch Pin Configuration
Based on Hitch Category
Figure 1-3**

Refer to Figure 1-4:

4. Slowly back tractor up to the Rotary Cutter while using tractor's 3-point hydraulic controls to align lower hitch link holes with clevis holes on the cutter.
5. Place tractor gear selector in park and/or set brakes, shut engine off and remove ignition key.
6. Aligned and positioned tractor's lower hitch holes in the clevises. Attach the lower arms to the clevises with hitch pins and secure with linch pins.
7. Adjust top center link in or out to align the center link hole with the cutter's center hitch pin hole. Connect top center link to cutter hitch pin hole using customer supplied clevis pin and linch pin.
8. Make certain the lower 3-point arms are stabilized to prevent excessive side movement.
9. Return to tractor and slowly raise tractor 3-Point hitch about 1 to 2 inches. Stow jack stands in the raised position.
10. Slowly operate tractor's 3-Point arms up and down to check clearance between cutter components and tractor components. Move or remove tractor drawbar if it interferes with cutter.
11. Adjust tractor's lower arms to level cutter frame from left to right.
12. Adjust center top-link to level cutter frame from front to rear.
13. Final deck leveling adjustments will be made later.

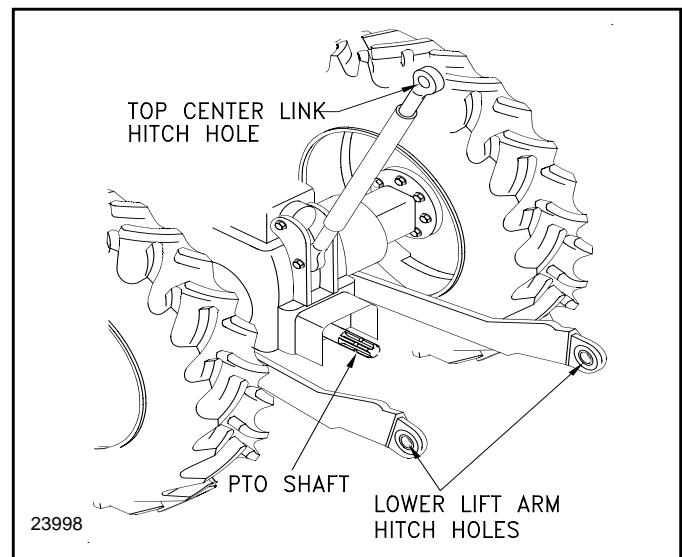

**Tractor 3-Point Hitch
Figure 1-4**

Section 1: Assembly & Set-up

PTO Hook-up

IMPORTANT: Do not engage tractor PTO until driveline is fully connected and hydraulic fluid has been added to the cutter reservoir.

IMPORTANT: A quick hitch may be used, but is not recommended because it moves the cutter deck back about 5" and impedes operator visibility.

IMPORTANT: Refer to Figure 1-5: Avoid premature driveline breakdown. A rotating driveline **must not exceed** an angle of 25 degrees up or down.

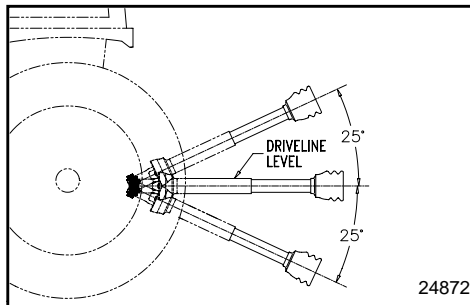

Maximum PTO driveline Movement
Figure 1-5

IMPORTANT: Always check driveline minimum length during initial setup, when connecting to a different tractor and when alternating between using a quick hitch and a standard 3-point hitch. More than one driveline may be required to fit all applications.

IMPORTANT: It is necessary to aligning the tractor's PTO shaft level with the Rotary Cutter's speed increaser shaft when checking driveline minimum length. Too long a driveline can damage tractor, gearbox and driveline.

Check Driveline Minimum Length

Refer to Figure 1-6:

1. Start tractor and slowly engage 3-point controls to move lower arms until the PTO shaft for the speed increaser is aligned and level with tractor PTO shaft. Securely block cutter in this position.
2. Place tractor gear selector in park, shut tractor engine off, set park brake and remove switch key.
3. Attach driveline to cutter and tractor as follows:
 - a. Slide inner yoke of driveline over speed increaser shaft and secure with locking collar.
 - b. Slide outer yoke of driveline over tractor PTO shaft and secure with locking collar.
 - c. Skip to step 5 if driveline fits between tractor and speed increaser. if driveline does not fit, continue with step 4 below.
4. The driveline will require shortening if it is too long to fit between tractor and speed increaser. Shorten driveline as follows:

- a. Make sure cutter and tractor PTO shafts are level with each other and cutter deck is securely supported at this height with support blocks.
- b. Pull driveline apart into two sections as shown in Figure 1-6.
- c. Attach outer driveline universal joint to tractor PTO shaft and inner driveline universal joint to the speed increaser shaft. Pull on each driveline section to be sure universal joints are secured.
- d. Hold driveline sections parallel to each other to determine if they are too long. The inner and outer shields on each section should end approximately 1" short of reaching the universal joint shield on the adjacent section (see "B" dimension). If they are too long, measure 1" ("B" dimension) back from the universal joint shield and make a mark at this location on the inner and outer shields.
- e. Cut off inner shield at mark ("X" dimension). Cut same amount off inner shaft ("X1" dimension). Repeat cut off procedure ("Y" & "Y1" dimensions) to outer driveline half.
- f. Remove all burrs and cuttings.

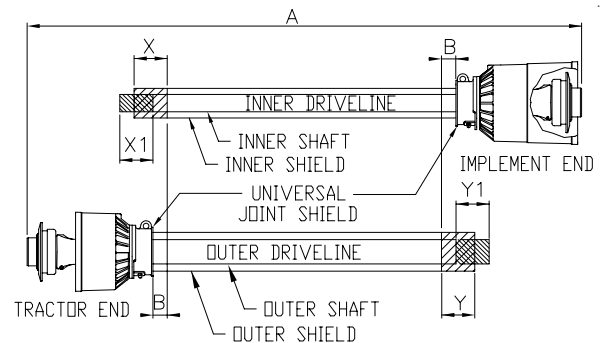

Shortening PTO Driveline Shields and Shafts
Figure 1-6

5. Apply multi-purpose grease to the inside of the outer driveline shaft and reassemble the two shafts.
 6. Attach inner driveline yoke to speed increaser shaft and outer driveline yoke to tractor PTO shaft.
 7. Move driveline back and forth to insure that both ends are secured. Reattach any end that is loose.
- IMPORTANT:** Two small chains supplied with the driveline must be attached to restrict shield rotation.
8. Hook the 1st safety chain in the hole on the outer driveline yoke shield and its opposite end to the tractor.
 9. Hook the 2nd safety chain in the hole on the inner driveline yoke shield and the opposite end to the cutter.
 10. Start tractor and raise cutter just enough to remove support blocks used in step 4 on page 15.
 11. Slowly engage tractor's 3-point controls to lower cutter. Check for sufficient drawbar clearance. Move drawbar ahead, aside or remove if required.

Section 1: Assembly & Set-up

Flow Control Valve Plumbing

An auxiliary flow control valve is included with the cutter when cylinders are solenoid controlled. The flow control valve diverts excess oil back to the tractor keeping oil cooler and back pressure down.

IMPORTANT: Damage to o-rings in the solenoid valve and/or in the cylinders may occur if oil becomes overheated.

Plumbing of pressure and return hoses must be checked to verify if correct for tractor rated GPMs. Reconfigure plumbing if needed as follows:

Tractors Rated at 15 GPM and Under

Refer to Figure 1-7:

1. Pressure line #1 is plumbed from the solenoid valve block to the flow control valve.
2. Return line #1 is plumbed from the solenoid valve block to a tee at the flow control valve.
3. Pressure line #2 is plumbed to the bottom of the flow control valve and the opposite end is fitted with a quick disconnect coupler.
4. Return line #2 is plumbed to the tee at the flow control valve and the opposite end is fitted with a quick disconnect coupler.

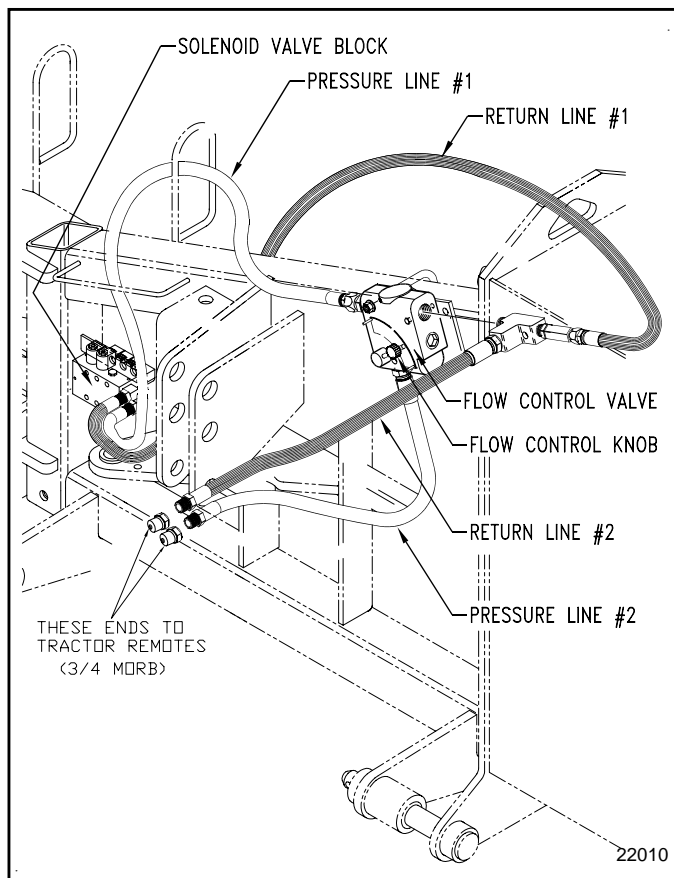

Plumbing For tractors rated at 15 GPM and under
Figure 1-7

Tractors Rated at 16 GPM and Above

Refer to Figure 1-8:

1. Return line #1 is plumbed to the solenoid valve block and the opposite end is fitted with a quick disconnect coupler.
2. Pressure line #1 is plumbed from the solenoid valve block to the flow control valve.
3. Pressure line #2 is plumbed to the bottom of the flow control valve and the opposite end is fitted with a quick disconnect coupler.
4. Return line #2 is plumbed to the tee at the flow control valve and the opposite end is plumbed to either the tractor sump or motor return line. Fittings to plumb to tractor sump or motor return line are customer supplied.
5. The unused port on the tee must be plugged.

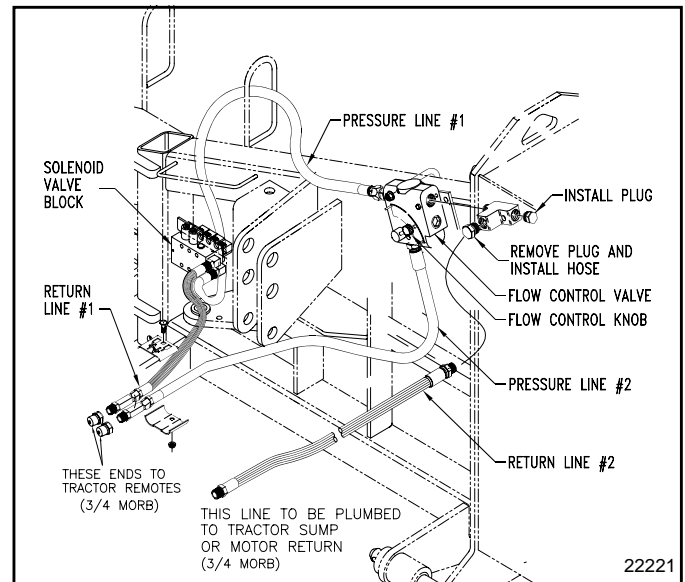

Plumbing for tractors rated at 16 GPM and above
Figure 1-8

Fill Hydraulic Reservoir

The Rotary Cutter is shipped without fluid in the hydraulic reservoir.

1. Park cutter on a level surface, set brake, turn off ignition switch and remove switch key.
2. Add 35 gallons of Mobil 424 to the hydraulic reservoir. Use care to ensure that dust or other foreign particles do not contaminate the fluid.

NOTE: Any high quality mineral based hydraulic fluid such as Mobil fluid 424 with a viscosity rating of 10W-30 is acceptable.

3. Remove filler cap and dipstick from reservoir and wipe clean. Fully insert filler cap with dipstick and remove. Check oil level on dipstick.
4. Fill with recommended oil to full mark if low.
5. Replace filler cap and dipstick.

Section 1: Assembly & Set-up

Hydraulic Hose Hook-up

! DANGER

Hydraulic fluid under pressure can penetrate skin. Wear protective gloves and safety glasses or goggles when working with hydraulic systems. Use a piece of cardboard or wood rather than hands when searching for hydraulic leaks. If hydraulic fluid is injected into the skin, it must be treated by a doctor within a few hours or gangrene may result.

There are two arrangements to hooking up the hydraulic hoses:

Arrangement - #1 Solenoid Controlled Cylinders:
Two duplex outlets are required to operator the arm cylinders, deck pivot cylinder and breakaway cylinder. Parallel arm and deck cylinders are solenoid activated with momentary push button switches at the control stick. Breakaway cylinder is controlled by tractor lever.

Arrangement - #2 Tractor Controlled Cylinders:
Four tractor duplex outlets are required to operator the arm cylinders, deck pivot cylinder and breakaway cylinder. Tractor levers operator all four cylinders.

NOTE: The response time with solenoid controlled cylinders is faster than tractor controlled cylinders. Therefore, the operator might want to consider arrangement #1 when frequent changes to deck positioning are required.

Solenoid Controlled Cylinders

Refer to Figure 1-9:

IMPORTANT: Plumbing instructions in step step 1 below are for cutters hooked to tractors capable of 16 GPM hydraulic flow and above.

1. Plumb return line #2 to tractor sump or motor return line (motor return line in Figure 5-5 on page 35). Fittings for plumbing are customer supplied.

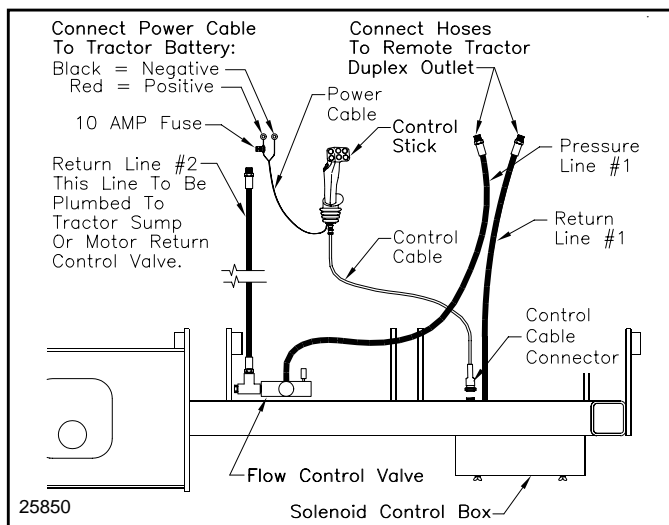

Hydraulic & Solenoid Hook-UP (16 GPM Flow & Above)
Figure 1-9

IMPORTANT: Plumbing instructions in steps step 2 to step 5 below are for all cutters with solenoid controlled cylinders.

Refer to Figure 1-9:

2. Connect pressure line #1 and return line #1 to one of the tractor's duplex outlets. Pioneer-quick disconnect hose couplings are supplied with each hose. Some tractors use other types of quick couplers.
3. Determine tractor's hydraulic configuration. Consult tractor's manual if unsure.
 - PC Closed Center System (Pressure Compensating)
 - LS Closed Center System (Load Sensing)
 - Open Center System

Refer to Figure 1-10:

4. Remove plastic cover located at the rear of the solenoid valve control box.
5. Adjust hydraulic flow control valve Knob at the solenoid valve block as follows:
 - **PC & LS Closed Center System: (PC = Pressure Compensating) (LS = Load Sensing)**
Set solenoid valve on RCP unit to "CLOSED" by turning the flow control knob "CLOCKWISE" until the knob will not rotate any further. Flow control setting to have all oil going to solenoid valve on unit.
 - **Open Center System:**
Set solenoid valve on RCP unit to "OPEN" by turning the flow control knob "COUNTER CLOCKWISE" until knob will not rotate any further. Adjust tractor flow control setting as outlined in "Tractor Flow Control" on page 25.

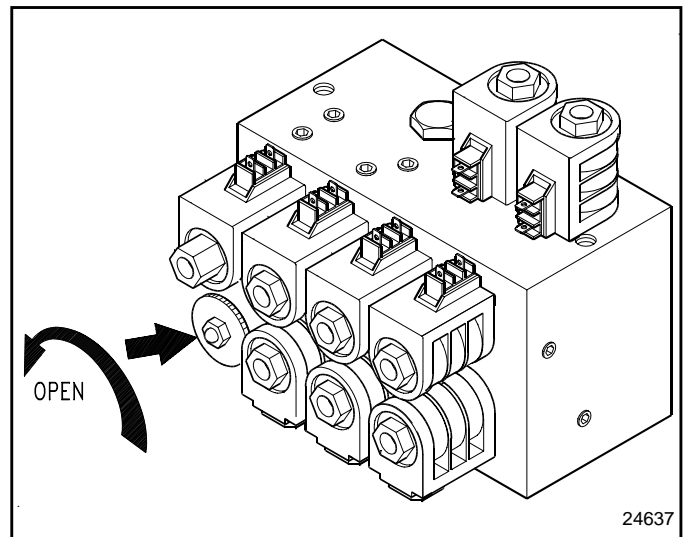

Flow Control Valve Knob
at the Solenoid Valve Block
Figure 1-10

Section 1: Assembly & Set-up

Tractor Controlled Cylinders

Refer to Figure 1-11:

Each tractor duplex outlet must be capable of infinite variable flow control by the operator and should have center detent "OFF" levers for controlled positioning of the parallel arm and deck cylinders. If gauge wheels are included, "ARM 2" and "DECK" levers must be capable of being placed in float position.

1. Connect six hoses (2 per cylinder) to 3 duplex outlets on your tractor as shown.
2. The hoses on each outlet should be connected such that when the control lever is pushed "forward", the arm (or deck) extends. If the levers operate in reverse, change hose hook-up at the duplex receptacle.

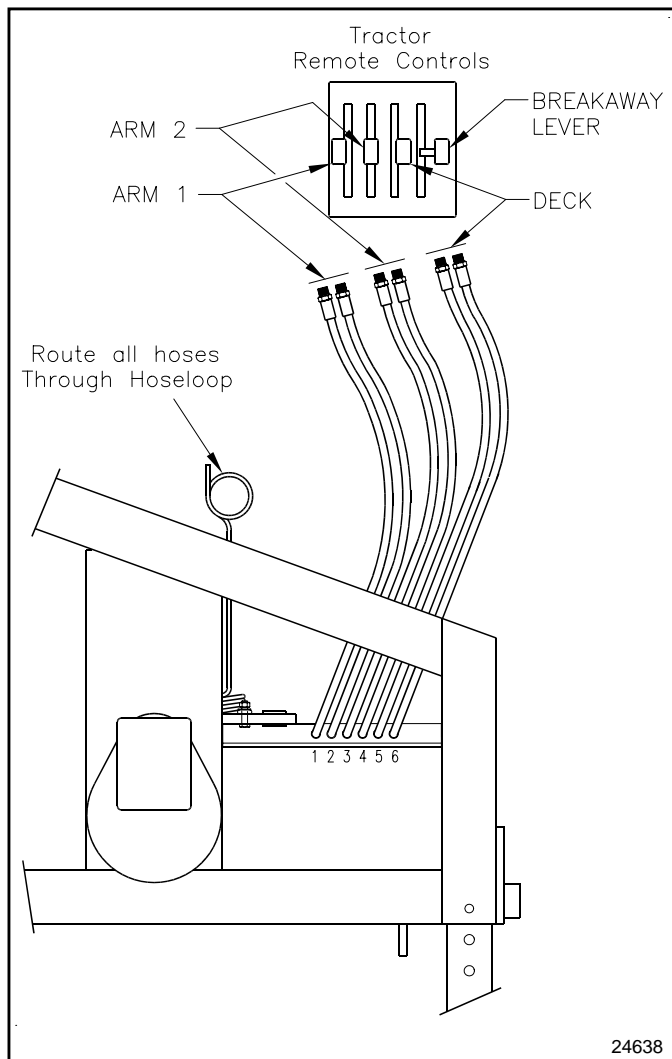

Hose Hook-up Without Solenoid Control
Figure 1-11

Breakaway Cylinder

Refer to Figure 1-12:

The breakaway cylinder protects the Rotary Cutter from damage if cutter deck or parallel arm contacts a solid object while moving forward. It does not protect cutter from damage while backing up. Always make certain the area behind the cutter is clear before backing up.

IMPORTANT: See Figure 5-7 on page 36. A 1/2" bolt is installed for shipping purposes only. This bolt **must be remove** before connecting the hydraulic hoses to the tractor.

1. Locate tension bolt shown in Figure 5-7 on page 36 and remove from cutter before connecting hydraulic hoses. **Do Not** reinstall tension bolt while using hydraulic breakaway.
2. Attach quick disconnect adaptors (customer supplied) to each breakaway hydraulic hose.
3. Attach breakaway hoses to a single duplex outlet on the tractor as shown in Figure 1-12.

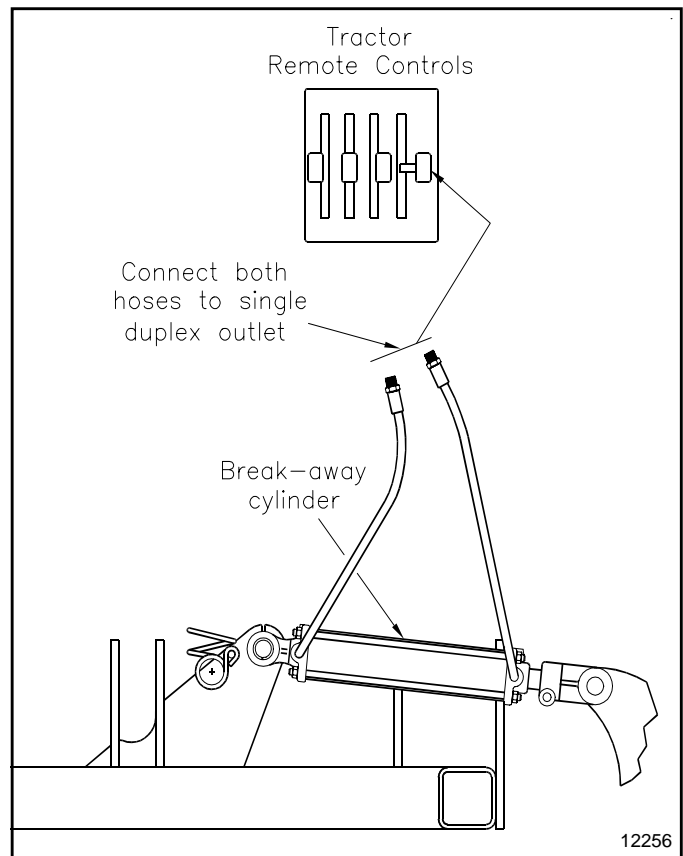

Breakaway Cylinder Hose Connections
Figure 1-12

Section 1: Assembly & Set-up

Electrical Hook-up

This section applies only to parallel arm cutters equipped with solenoid controlled cylinders. Skip to “Tractor Console Control Levers” on page 22 if not equipped with this arrangement.

IMPORTANT: Connect power cable leads only to 12 VDC power source. Connection to 24 VDC or larger will damage electrical components.

NOTE: Arm and deck functions will be slow if dual 6 volt batteries are not hooked up correctly. See tractor’s manual for proper 12 volt hook-up when tractor has dual 6 volt batteries.

Refer to Figure 1-13:

1. Find a suitable location to place control stick when not in use.
 - a. A suitable location for the control stick is usually close to the operator’s right hand side on the tractor fender or fender console. Exact location should be convenient for the operator.
 - b. When in use, grip the control stick such that the push button switches are easy to access.

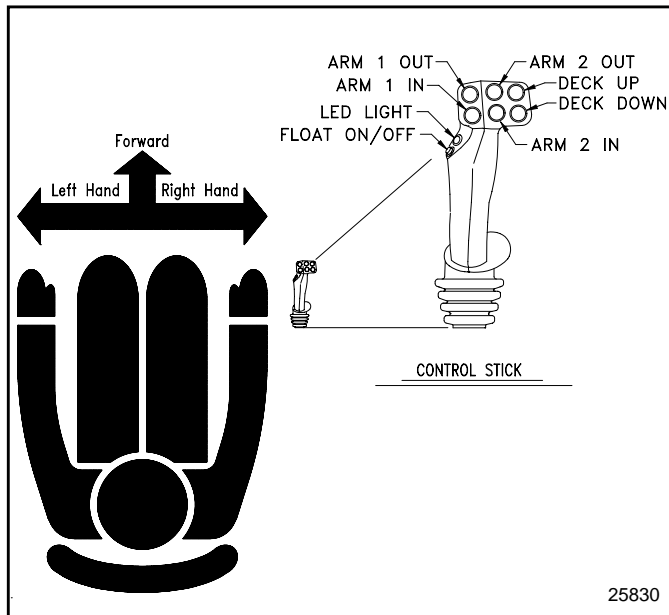

Control Stick (Shown with Float Switch)
Figure 1-13

Refer to Figure 1-9 on page 17:

2. Route control cable from control stick to solenoid control box on the cutter and connect to mating connector.
3. Route power cable to the tractor battery positive power source or circuit breaker panel. A 10 Amp or larger fuse/circuit breaker source should be used.
 - a. Connect red lead to positive power source.
 - b. Connect black lead to negative power source.

Switch Functions

Refer to Figure 1-14:

The following operational checks assumes that the cutter is equipped with solenoid controlled cylinders. Skip to “Tractor Console Control Levers” on page 22 if not set-up for this arrangement.

NOTE: The control stick wiring includes a 10 amp fuse on the red power cable. If overheated, the fuse will open stopping all power to the controls. The fuse must be replaced before power will resume.

NOTE: Make sure hydraulic plumbing is configured correctly for your tractor’s hydraulic flow rate. See “Flow Control Valve Plumbing” on page 16. Consult your tractor’s manual and/or your dealer if unsure of your tractor’s flow rate.

The control stick will have 6 momentary push button switches for pivoting the deck, moving “ARM 1” and moving “ARM 2”. If the deck is equipped with gauge wheels, the control stick will also include an “ON/OFF” Float Switch and an LED light to indicate when the Float Switch is “ON”.

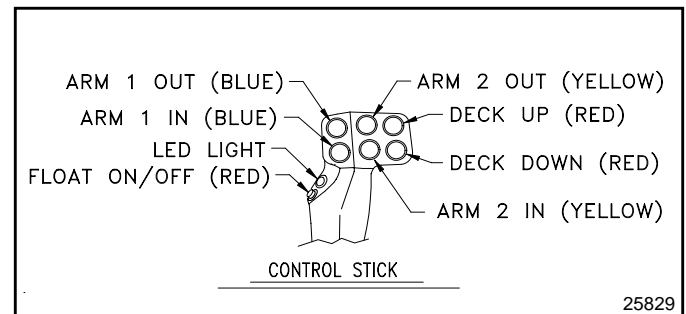

Control Stick
Figure 1-14

Deck Up/Down Switches

Operate Deck UP/DOWN push button switches to keep deck parallel to the ground. Float Switch and LED light must be “OFF” before the deck switches will function.

1. Press and hold “DECK UP” push button to pivot end of deck up. Release switch to stop movement.
2. Press and hold “DECK DOWN” push button to pivot end of deck down. Release switch to stop movement.

ARM 2 OUT/IN Switches

ARM 2 OUT/IN push button switches extends and retracts the outboard parallel arm. Deck pivot angle remains unchanged while operating these two switches. Float Switch and LED light must be “OFF” before “ARM 2” switches will function.

1. Press and hold “ARM 2 OUT” push button to extend outboard arm. Release switch to stop movement.
2. Press and hold “ARM 2 IN” push button to retract outboard arm. Release switch to stop movement.

Section 1: Assembly & Set-up

ARM 1 OUT/IN Switches

“ARM 1 OUT/IN” push button switches extends and retracts the inboard parallel arm. Deck pivot angle remains unchanged while operating these two switches. “ARM 1” push button switches are always functional and will operate with Float Switch turned “ON” or “OFF”.

1. Press and hold “ARM 1 OUT” push button to extend inboard arm. Release switch to stop movement.
2. Press and hold “ARM 1 IN” push button to retract inboard arm. Release switch to stop arm movement.

Float ON/OFF Switch

The control stick will be equipped with a Float Switch and LED light only if the cutter deck is equipped with gauge wheels.

Press and release the Float Switch to turn float function “ON”. Press and release the switch again to turn float function “OFF”. Toggling the switch back and forth in this fashion will turn float function “ON” & “OFF” repetitively. LED light illuminates only when the Float Switch is “ON”.

Float Switch Turned ON:

When “ON”, the Float Switch allows the deck to be carried on the gauge wheels. “Deck UP/DOWN” and “ARM 2 OUT/IN” push button switches are bypassed allowing deck position to change with the terrain.

“ARM 1” push button switches are not bypassed. Therefore, “ARM 1 IN” switch can be pressed to move deck closer and to raise parallel arms for clearing objects. “ARM 2 OUT” switch can be pressed to move deck farther away from tractor.

The deck can be raised with “ARM 2 OUT” push button switch or pivoted up with “DECK UP” push button switch but neither switch will hold the deck to this changed position. Instead, the deck will fall onto the gauge wheels as soon as the push button is released.

Float Switch Turned OFF:

The Float Switch, when “OFF”, allows the operator to control all six momentary push button switches individually (ARM 1, ARM 2 & Deck).

Turn Float Switch “OFF”:

1. When transporting the cutter.
2. When crossing ditches that will cause the deck to become high centered or gauge wheels to catch stopping forward travel.
3. When encountering raised areas such as banks, stumps, rocks or other protrusions that the gauge wheels cannot and/or should not roll over.
4. When the operator wants full control of cutter deck and parallel arms.

Operational Checks

Transport Safety Chain

Refer to Figure 1-15 & Figure 1-16:



WARNING

Transport safety chain must remain hooked to the deck until ready to extend parallel arms and deck cylinder. Float Switch must always be “OFF” until deck has been lowered to ground level.

The transport safety chain should always be hooked to the deck hook when cutter is folded up. Otherwise, the operating levers and/or push button switches could be bumped or hoses could burst allowing deck to fall and cause damage to cutter, tractor, and anyone nearby.

Before unhooking the transport safety chain, make sure the arm and deck cylinders are retracted and if available, the Float Switch is set to “OFF”. Do not force safety chain off of the deck hook. If safety chain does not remove easily, investigate the problem and correct before continuing. Once unhooked, store safety chain on storage hook for safe keeping.

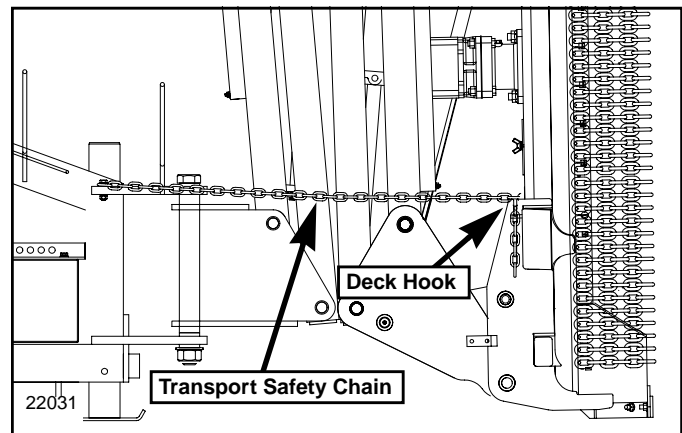

Transport Safety Chain Shown Hooked for Transport
Figure 1-15

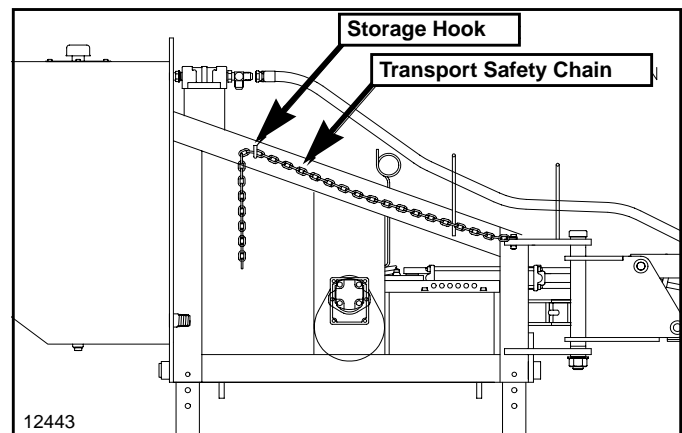

Transport Safety Chain Shown in Storage Position
Figure 1-16

Section 1: Assembly & Set-up

Momentary Push Button Switches

Cycle "ARM 1", "ARM 2", and "DECK" cylinders to ensure they operate properly as follows:

1. If included, make sure Float Switch is set to "OFF" and LED light is "OFF".

Refer to Figure 1-15 & Figure 1-16 on page 20:

2. Read and understand "Transport Safety Chain" on page 20 before continuing.
3. Remove transport safety chain from the latched position and place loose end on storage hook.
4. Start tractor and adjust 3-point hitch until PTO driveline is approximately level.
5. Two hoses from the solenoid control valve were connected to the tractor's single duplex outlet in step 2 on page 17. Lock the control lever for this duplex outlet in either the "Extend Position" or the "Retract Position".

Refer to Figure 1-17:

6. Press and hold "ARM 1 OUT" push button switch. The inboard parallel arm should extend outward. If it does not move, or moves in the wrong direction (retracts), you should do one of the following:
 - a. Change the position of the console lever from automatic retract to automatic extend or vice-versa.
 - b. Reverse the hoses at the duplex outlet.
7. Press and hold "ARM 2 OUT" push button switch. The outboard parallel arm should extend.

8. Press and hold "DECK DOWN" switch. The deck cylinder should extend and deck should pivot down.

NOTE: Cycle all three cylinders to full extension and retraction to remove any air that might be trapped in the system.

9. Check hydraulic fluid level in your tractor's reservoir. If low, add fluid to the system before proceeding. The cylinders and hoses will require approximately 1 3/4 gallons from the tractor.

Float Switch Control

Gauge wheels must be installed before checking Float Switch operation. Install gauge wheels per instructions on page 24 titled "Gauge Wheel Model Set-up".

Make this functional check with "ARM 1" and "ARM 2" approximately 3/4 extended and with the cutter deck resting on its gauge wheels.

1. Operate "ARM 1 OUT", "ARM 2 OUT" and "DECK DOWN" push button switches to extend the arms and to lower the deck to ground level.
2. Change Float Switch from "OFF" to "ON". LED light should be illuminated when Float switch is "ON".

IMPORTANT: Do Not push "DECK" and "ARM 2" switches for more than two seconds before releasing them when Float Switch is turned to "ON".

3. Press and hold "DECK UP" push button switch for under two seconds. The deck cylinder should retract pivoting the deck up. Release "DECK Up" switch and deck should fall back onto its gauge wheels.
4. Press and hold "ARM 2 OUT" push button switch for under two seconds. "ARM 2" should extend raising the deck up. Release switch and the deck should fall back onto its gauge wheels.
5. For safety, return Float Switch to "OFF". LED light should be out (not illuminated).

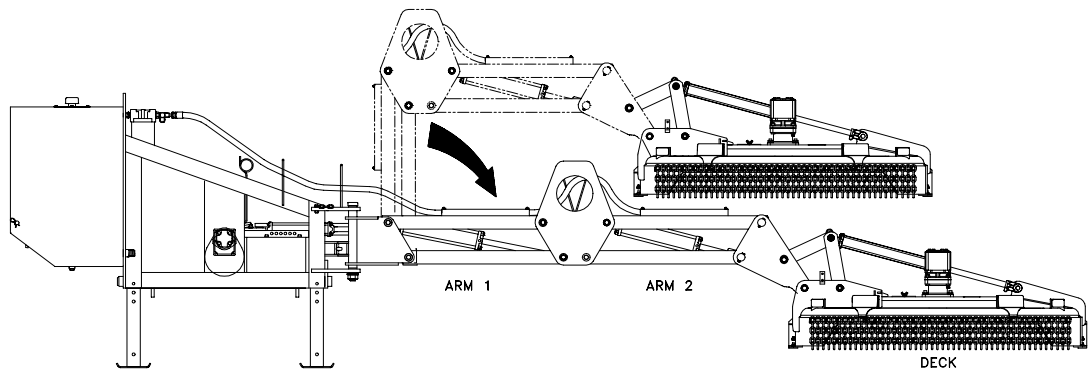
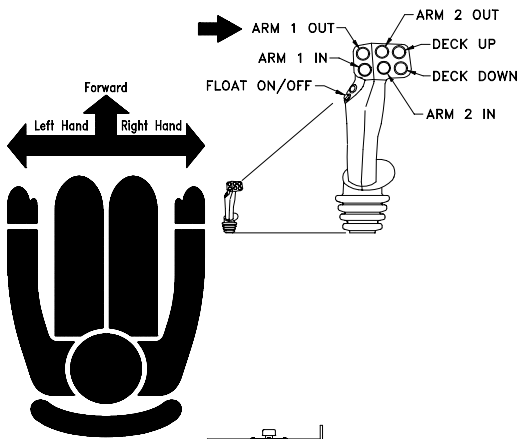

Parallel Arm Movement
Figure 1-17

24612

Section 1: Assembly & Set-up

Tractor Console Control Levers

Cycle parallel arm cylinders and deck cylinder with tractor console controls to ensure they operate properly as follows:

Pre-Operational Instructions

Refer to Figure 1-15 & Figure 1-16 on page 20:

1. Read and understand "Transport Safety Chain" on page 20 before continuing.
2. Remove transport safety chain from its latched position and place loose end on the storage hook.
3. Start tractor and adjust 3-point hitch until PTO driveline is approximately level.

Center Detent Control

Refer to Figure 1-18:

4. Operate tractor console control lever designated for "ARM 1" by pushing it forward. The inboard arm should extend outward. If "ARM 1" retracts, reverse hydraulic hoses at the duplex outlet (See Figure 1-11 on page 18).
5. Repeat this procedure for remaining arm and deck cylinders.

NOTE: Cycle all cylinders to full extension and retraction to remove any air that might be trapped in the system.

6. Check hydraulic fluid level in your tractor's reservoir. If low, add fluid to system before proceeding. The cylinders and hoses will require approximately 1 3/4 gallons from the tractor.

Float Positioning Control

Gauge wheels must be installed before setting tractor operator levers to float position. Install gauge wheels per instructions on page 24 titled "Gauge Wheel Model Set-up".

To make this functional check, "ARM 1" and "ARM 2" must not be fully extended. Cutter deck should be resting on the gauge wheels.

1. Operate all three tractor console control levers and lower deck to ground level.
2. Set only "ARM 2" and "DECK" control levers in float position. Consult tractor manual if operator is unsure of where float position is for the tractor control levers.
3. Retract "ARM 1" control lever. "ARM 2" and "DECK" cylinders should float (change position) allowing deck gauge wheels to remain resting on the ground.
4. Return control levers to center detent position to regain full control of "ARM 2" and "DECK" pivot cylinders.

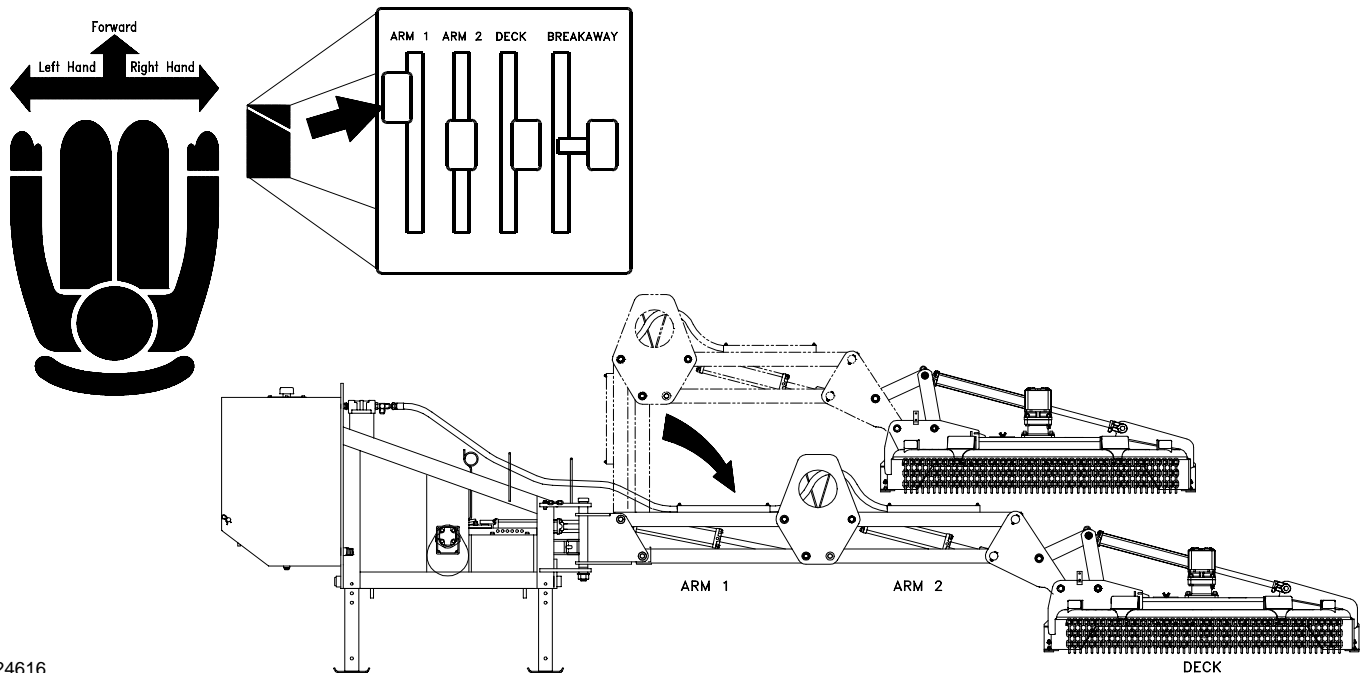

24616

Parallel Arm Movement
Figure 1-18

Section 1: Assembly & Set-up

Pump & Motor Operation

1. Move tractor and cutter to a remote location away from all other personnel to check pump and motor operation.

Refer to Figure 1-19:

IMPORTANT: Make sure the hydraulic reservoir shut-off valve is fully **OPEN** before engaging PTO. Damage will occur to pump if shut-off valve is **CLOSED** and PTO is running.

2. Check Hydraulic Reservoir shut-off valve. Make sure it is fully OPEN before engaging PTO.
3. Position cutter deck flat on ground or concrete surface.

IMPORTANT: Always operate tractor PTO speed at cutter rated PTO speed and never faster. Damage to the cutter can result when operating above designed PTO speed.

4. Set tractor speed at idle and **SLOWLY** engage PTO to start blade rotation. On initial start-up, blade position may cause deck to “vibrate”. After 2 to 3 revolutions, these vibrations should stop. If deck continues to vibrate, shut PTO off, raise cutter deck and check for locked blades (blades that are overlapped and locked together).
5. Gradually increase engine rpm until PTO output has reached cutter rated PTO speed, either 540 rpm or 1000 rpm. The deck should not exhibit excessive vibration.

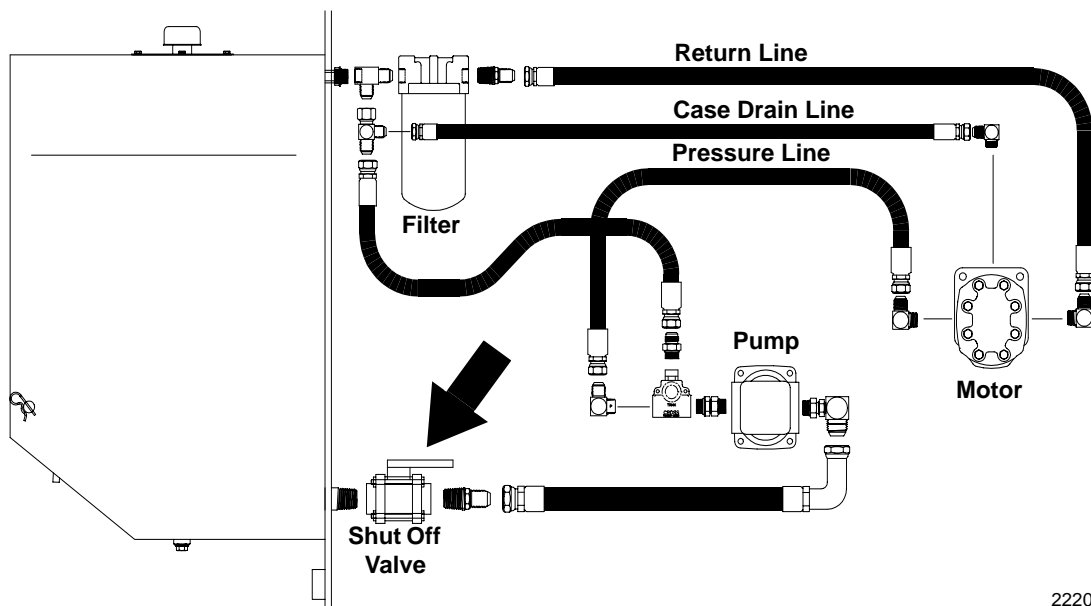

22207

Hydraulic Pump Motor Circuit
Figure 1-19

Section 1: Assembly & Set-up

Gauge Wheel Model Set-up

Refer to Figure 1-20:

The deck with gauge wheels is shipped from the factory completely assembled to the parallel arm with the exception of installing the rear ratchet jack and one gauge wheel.

Ratchet Jack Installation

1. Check 5/8" hex flange lock nuts attached to bolts (#3). They should be drawn up snug, not tight. A-frame (#2) should pivot freely on the two bolts.
2. Cut ties securing A-frame (#2) and rotate frame to position it behind the deck as shown.
3. Install ratchet jack (#8) to cutter deck with 1" dia. clevis pin (#6). Secure with hair pin (#3).
4. Attach opposite end of ratchet jack to A-frame (#2) with 1" dia. clevis pin (#6). Secure with hair pin (#5).

Gauge Wheel Installation

1. Install 1 1/4" I.D. machine washer (#4) over yoke spindle (#1) as shown.
2. Insert yoke spindle (#1) into the front support frame.
3. Install second 1 1/4" I.D. machine washer (#4) over yoke spindle (#1).
4. Secure yoke spindle to frame with 5/16" dia. roll pin (#7).

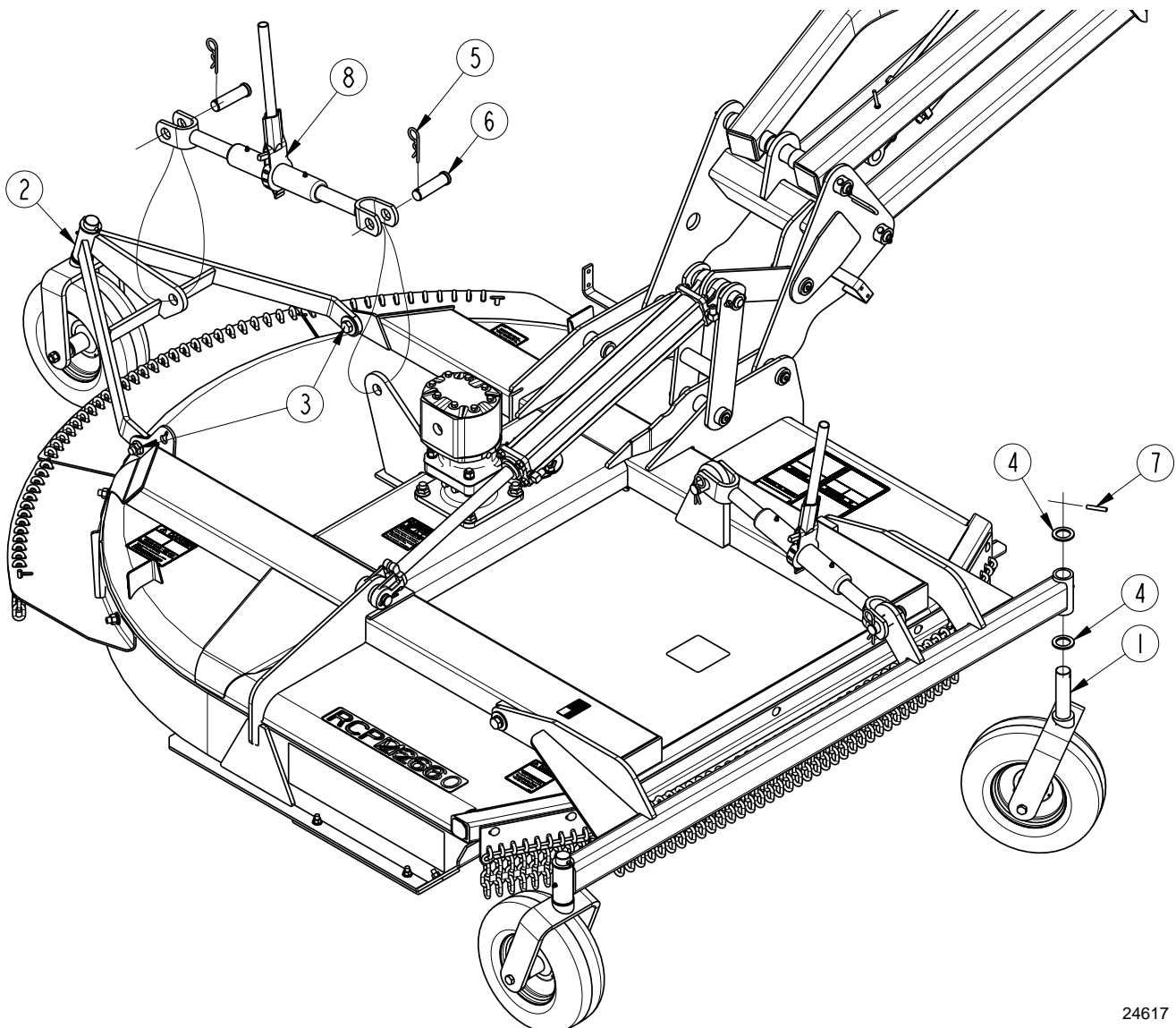

Gauge Wheel Set-Up
Figure 1-20

24617

Section 2: Adjustments

Hydraulic Flow Control Settings

The hydraulic cylinders require 5 GPM (gallons per minute) to function properly. This is set by adjusting the flow control valve(s) and then timing how long it takes for the cylinder to fully retract. The valve is adjusted correctly when it takes 5 seconds to retract.

Cutter Flow Control

Refer to Figure 2-1:

IMPORTANT: Oil overheating may occur if flow control is not achieved. Damage to o-rings in the solenoid valve and/or in the cylinders may occur if oil becomes overheated.

An auxiliary flow control valve is included with the cutter when provided with solenoid controlled cylinders. The flow control valve diverts excess oil back to the tractor keeping oil cooler and back pressure down.

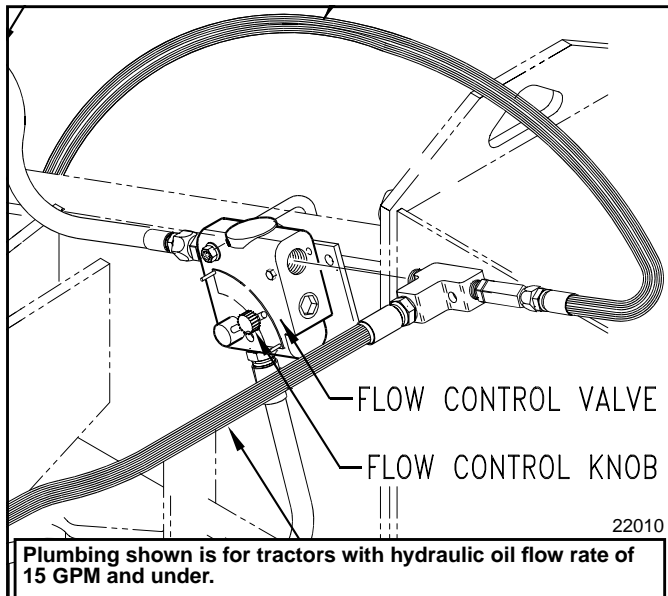

Flow Control Valve for Solenoid Operated Cylinders
Figure 2-1

Refer to Figure 2-2:

1. Set Rotary Cutter in folded transport position. (All parallel arm and deck cylinders are fully retracted when in transport position.)
2. Press and hold "ARM 2 OUT" push button switch to fully raise outboard arm up. Release switch when cylinder is fully extended.
3. Press and hold "ARM 2 IN" push button switch and time how long it takes to cycle from fully extended to fully retracted.
4. Adjust flow control knob (See Figure 2-1) until cycle time is 5 seconds.

Tractor Flow Control

Refer to Figure 2-2:

NOTE: Parallel Arm Cutters with (S/N 163695-) will require flow control valve kit #316-068K if your tractor does not have flow control (turtle/rabbit control) or if your tractor uses an open center hydraulic system. Check your tractor's operator's manual to determine your tractor's set-up.

The tractor's turtle/rabbit flow control valves are used when all hydraulic connections are connected directly to the tractor outlets.

1. Set cutter in folded transport position. (All parallel arm and deck cylinders are fully retracted when in transport position.)
2. Operate tractor "ARM 2" lever to raise outboard arm fully up as shown.
3. Operate tractor "ARM 2" lever to fully retract outboard arm and time how long it takes to cycle from fully extended to fully retracted.
4. Adjust turtle/rabbit control until cycle time is 5 seconds.
5. Repeat steps 2 and 3 for "ARM 1" and "DECK" cylinders.

If the cutter is having hydraulic overheating problems and the turtle/rabbit flow control valves have been set correctly, then check tractor operator's manual for power beyond hook-up.

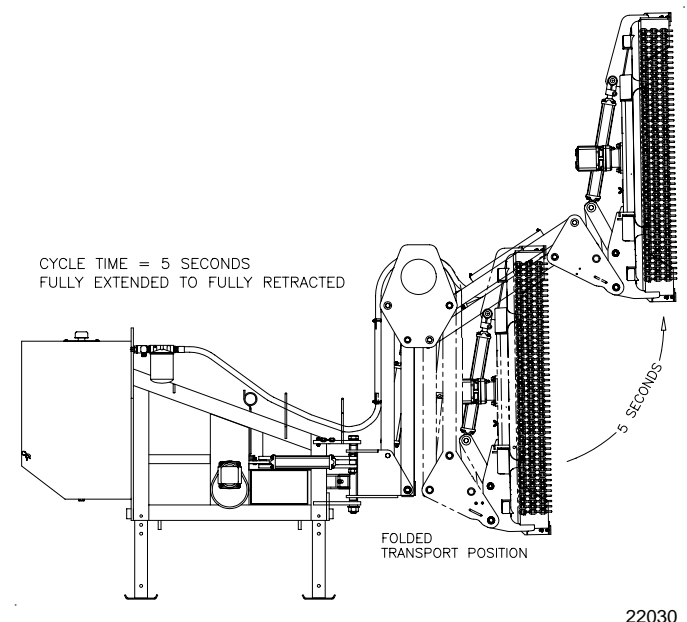

Cycle Time (Fully Extended to Fully Retracted)
Figure 2-2

Section 2: Adjustments

Deck Level Adjustments

Deck level adjustments should be made on a level surface large enough to be level under the tractor and deck with parallel arms fully extended.

Cutter Without Gauge Wheels

Refer to Figure 2-3:

1. Raise tractor 3-Point hitch until PTO driveline is approximately level.
2. Adjust arm cylinders so that the parallel arms are approximately 3/4 extended and deck cylinder so that the deck is 3 to 4 inches off the ground.
3. Continue adjusting deck cylinder until deck is level from left to right.
4. Extend "ARM 1" cylinder until skid shoes are 2 to 3 inches off the ground.
5. Place a level on the cutter deck to read forward/aft attitude.
6. Adjust center 3-Point top-link so that the front of the cutter deck is slightly lower than the rear by approximately 1/2".

Cutter With Gauge Wheels

Refer to Figure 1-20 on page 24 & Figure 2-3:

1. Make certain tractor control levers are set to center detent position and if available, Float Switch on the control stick is turned "OFF".
2. Raise tractor 3-Point hitch until PTO driveline is approximately level.
3. Adjust arm cylinders so that the parallel arms are approximately 3/4 extended and deck cylinder so that the gauge wheels are 3 to 4 inches off the ground.
4. Continue adjusting deck cylinder until deck is level from left to right.
5. Extend "ARM 1" cylinder until gauge wheels are 1 to 2 inches off the ground.

6. Place a level on the cutter deck to read forward/aft attitude.

IMPORTANT: Gauge wheels should not touch ground while adjusting the center 3-point link. If needed, retract "ARM 1" slightly to raise gauge wheels off the ground.

7. (See Figure 2-3) Adjust center 3-Point link (#3) so that the front of the cutter deck is slightly lower than the rear by 1/2".
8. Adjust front gauge wheels to the approximate cutting height (Vertical distance from bottom of front gauge wheels to tip of front cutting blade).
9. Adjust rear gauge wheel to be the same distance off the ground as the front gauge wheels.
10. Switch "ARM 2" and "DECK" cylinders to float position. This will allow the cutter deck to be supported by the gauge wheels.
 - a. **Solenoid controlled cylinders:**
Change Float Switch from "OFF" to "ON".
 - b. **Tractor controlled levers:**
Place "ARM 2" and "DECK" control levers in float position.
11. Recheck deck height at the front and rear. Make final adjustments to level the deck by changing the rear gauge wheel height until the deck rear is 1/2" higher than the deck front.

NOTE: Nominal cutting height is the distance from tip of front cutting blade to ground level.

12. Change nominal cutting height by raising or lowering the front and rear gauge wheels equally until the blade at the front is set at the correct height.
13. Recheck deck height at the front and rear. If needed, adjust rear gauge wheel until deck rear is 1/2" higher than deck front.

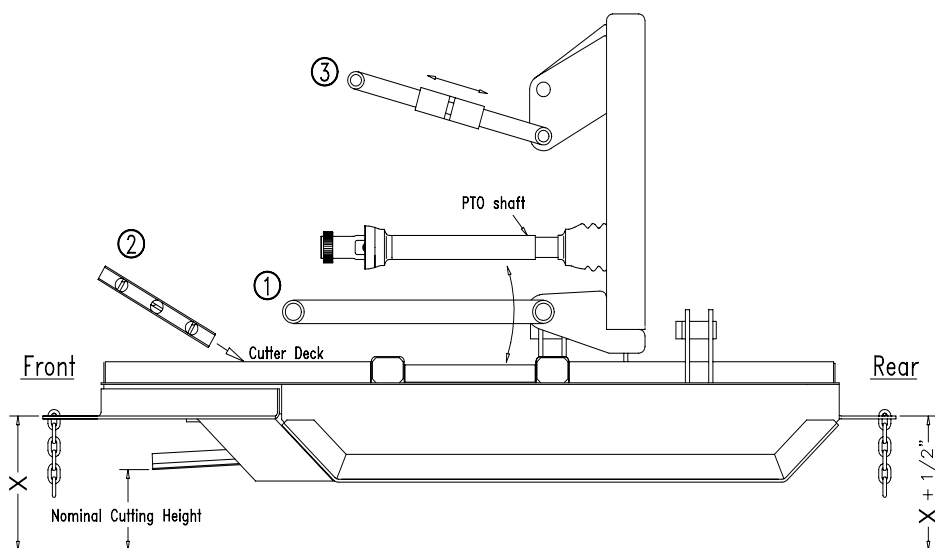

Deck level Adjustments
Figure 2-3

Section 3: Operating Procedures

Operating Check List

The RCP2660, RCPM2660, RCP3060 & RCPM3060 Series Parallel Arm Hydraulic Rotary Cutters are uniquely versatile and powerfully productive cutting implement in the hands of a knowledgeable, skilled and responsible operator. These cutters are frequently operated on inclines in populated and high traffic areas. Therefore, it is absolutely essential that no one operates these cutters without first having read, fully understood and become totally familiar with the Operator's Manual. Make sure the operator has paid particular attention to:

- **Important Safety Information**, pages 1 to 9
- **Section 1: Assembly & Set-up**, page 12
- **Section 2: Adjustments**, page 25
- **Section 3: Operating Procedures**, page 27
- **Section 6: Maintenance & Lubrication**, page 37

Make the following inspections after attaching cutter to the tractor. See hook-up instructions beginning on page 14. Make certain PTO is disengaged and completely stopped.

1. Inspect tractor safety equipment to make sure it is in good working condition.
2. Carefully raise and lower implement with tractor 3-point controls to ensure drawbar, tires, and other equipment on the tractor do not contact the frame or PTO driveline.
3. Lubricate Rotary Cutter as needed. Refer to "Lubrication Points" on page 40.
4. Check cutter initially and periodically for loose bolts and Pins. Refer to "Torque Values Chart" on page 48.
5. Check all guards and shields to make certain they are in good working condition and in place.
6. Check all hoses and wires to be sure that they will not contact PTO driveline.
7. Inspect Hydraulic hoses for wear, damage and hydraulic leaks. See "Avoid High Pressure Fluids Hazard" on page 3. Replace damaged and worn hoses with genuine Land Pride parts.
8. With PTO disengaged and completely stopped, check cutting blades for sharpness.
9. Check the following with deck placed in transport position, PTO disengaged and completely stopped, and the transport safety chain is engaged in the deck hook. Wear your safety glasses.
 - a. Check blades to be sure that they are not locked (overlapped) together.
 - b. Check blades for sharpness.
 - c. Ensure that both blade bolts and center blade carrier hub nuts are tight.
10. Check tractor safety equipment. Particularly check the ROPS (Roll Over Protective Structure) and the Operator Protective shield (optional, see page 31) to be sure both are in good working condition.

Transporting

CAUTION

Always use accessory lights and devices for adequate warning to operator's of other vehicles when traveling on public roads, night or day. Comply with all federal, state and local laws.

CAUTION

When traveling on public roads whether at night or during the day, use accessory light and devices for adequate warning to operators of other vehicles. Comply with all federal, state and local laws.

CAUTION

Always disengage tractor PTO before transporting cutter to avoid injury from thrown objects or blade contact.

CAUTION

The cutter is 10'-6" wide. Care should be taken when encountering oncoming traffic and roadside obstructions. Reduce speed and/or stop if in doubt about safe clearance. Resume traveling speed only after it is safe to proceed.

1. Disengage tractor PTO.
2. If provided, set Float Switch to "OFF". Make sure LED light is "OFF".
3. Retract both parallel arms and position deck vertically with blades facing outboard (away from tractor).
4. Manually hook transport safety chain to deck hook as shown in Figure 1-15 on page 20.
5. Raise hitch up to provide 8" - 12" clearance between deck and ground.
6. Always transport to the work site at a safe speed. When traveling on roadways, transport in such a way that faster moving vehicles may pass you safely. A slow moving vehicle sign should always be properly displayed when using public roads or right-of ways.
7. Be sure to reduce tractor ground speed when turning; and leave enough clearance so the Rotary Cutter does not contact obstacles such as buildings, trees or fences.
8. When traveling over rough or hilly terrain, shift tractor to a lower gear.

Section 3: Operating Procedures

Cutting Operation



WARNING

The following operating procedures must be carefully read and fully understood. You are the tractor operator and are therefore responsible for the safe operation of this unit. All other persons must be cleared of the area. Cutter operation must be stopped when in the vicinity of other persons.



CAUTION

Do not over speed PTO or machine damage may result. The RCP2660 & RCP3060 operates at 540 RPM and RCPM2660 & RCPM3060 operates at 1000 RPM.



DANGER

PTO shields must be secured in place when operating to avoid injury or death from entanglement in rotating drivelines.



WARNING

The Parallel Arm Rotary Cutter is designed to cut grass and brush up to 2" in diameter. Using this cutter for another type of work can damage the drive components, deck and support frame.



WARNING

Do not operate this cutter under any terrain conditions that would place tractor at an angle exceeding 30 degrees either front-to-rear or left-to-right. Make sure adequate ballast weights are provided on both the front of tractor and left of tractor and left hand side of cutter to assure tractor stability.



DANGER

Rotary Cutters have the ability to discharge objects at high speeds. Front & rear deck safety shields are required!



DANGER

Do not use deck as a fan. Cutting blades are not properly designed or guarded for this use. Using deck as a fan can result in injury and/or death.



DANGER

Hydraulic fluid under pressure can penetrate skin. Wear protective gloves and safety glasses or goggles when working with hydraulic systems. Use a piece of cardboard or wood rather than hands when searching for hydraulic leaks. If hydraulic fluid is injected into the skin, it must be treated by a doctor within a few hours or gangrene may result.

IMPORTANT: Avoid catching hydraulic hoses on brush, post, stumps, and other protrusions that could damage and/or break them.

IMPORTANT: Do not exceed rated PTO speed of the cutter. Excessive engine speed will cause damage to the speed increaser and other power train components.

IMPORTANT: Control stick must be kept out of the rain during operation and when in storage. Never use high pressure wash to clean the control stick.

1. After attaching cutter to the tractor, carefully raise and lower the unit to ensure that the drawbar, tires, and other equipment on the tractor do not contact cutter frame or PTO driveline.
2. Remove and stow transport safety chain before extending the arms or lowering the deck.
3. Adjust tractor lower 3-point arms such that PTO driveline is approximately level.
4. Skip to step step 5 if control stick is not included. If control stick is included, read and fully understand "Switch Functions" on page 19.
5. Extend parallel arms and deck cylinder as follows:

Deck without gauge wheels:

- a. Starting with "ARM 1", extend the two parallel arms switching back-and-forth from "ARM 1" to "ARM 2" until both arms are positioned as needed.
- b. Extend "DECK" cylinder until deck is parallel to the ground.
- c. Adjust deck and parallel arms to locate cutter for best operator visibility. Normally, this is with arms extended out approximately 3/4 of full extension.

Deck with gauge wheels:

- a. Make certain tractor control levers are set to center detent position and if available, Float Switch on the control stick is "OFF".
- b. Starting with "ARM 1", extend the two parallel arms switching back-and-forth from "ARM 1" to "ARM 2" until both arms are positioned as needed.
- c. Extend "DECK" cylinder until deck is resting on its gauge wheels.
- d. Switch "ARM 2" and "DECK" cylinders to float position.
 - **Solenoid controlled cylinders:**
Change Float Switch from "OFF" to "ON".
 - **Tractor controlled levers:**
Place "ARM 2" and "DECK" control levers in float position.
- e. Adjust ratchet jacks to raise or lower deck to desired cutting height. See also "Deck Level Adjustments" on page 26
- f. Adjust "ARM 1" to locate cutter for best operator visibility. Normally, this is with arms extended out approximately 3/4 of full extension.

Section 3: Operating Procedures

IMPORTANT: Your Rotary Cutter is equipped with free swinging cutting blades to reduce shock loads to the cutter when striking obstacles. The cutting blades can lock together while transporting. Always check for locked blades before starting to cut.

6. Set tractor throttle to idle or slightly above idle and slowly engage PTO. Start-up vibration is normal and should stop after a few revolutions of the blade carrier. Stop PTO rotation if vibration continues. Wait for PTO to come to a complete stop and then dismount from tractor to check for probable causes such as blades locked together.
7. Once cutter is running smoothly, increase tractor PTO speed to cutter rated PTO speed. Stop PTO rotation immediately if vibration occurs. Wait for the PTO to come to a complete stop and then dismount from the tractor to check for probable causes.
8. Optimum ground speed will depend on density of material being cut, terrain and operator skill. If in doubt, change gears to reduce tractor ground speed to a comfortable level.

Breakaway Operating Procedures

Refer to Figure 3-1:

The deck and parallel arms are designed to breakaway should the cutter head make contact with an immovable object or irregular terrain during forward travel. This "breakaway" feature will protect the cutter against structural damage by allowing the deck and parallel arms to pivot backwards.

Upon breakaway, the cutter head must be reset to original "home" position before normal cutting operations can resume.

IMPORTANT: *Do not attempt to operate cutter in reverse.* The breakaway mechanism will function correctly **ONLY** while tractor is moving forward. Cutting while backing up may cause structural damage to the parallel arms and deck if cutter head strikes a solid or immovable object.

1. Raise arms and deck up to clear any obstacles located behind the cutter deck.
2. Slowly back cutter away from any obstacles that will interfere with pivoting unit back to "home" position.
3. Use tractor's remote (breakaway cylinder) control to pivot unit back to "home" position.

Cylinder Shear Bolt

Refer to Figure 3-1:

A shear bolt is located at the rod end of the breakaway cylinder. This bolt may shear under the following conditions:

- After breakaway, the operator backs the tractor away from the obstruction, but encounters an additional obstruction or immovable object while backing up.

Specifically, the operator did not raise the deck high enough to clear the object before backing up.

- The operator tried to reset the deck and parallel arms by backing the tractor into an obstruction rather than using the tractor's remote cylinder control.
- The shear bolt has become fatigued after repeated breakaway and reset cycles.
- The shear bolt self-locking nut has been tightened against the clevis causing a pre-loaded stress on the bolt and the bolt to shear at a reduced breakaway force.

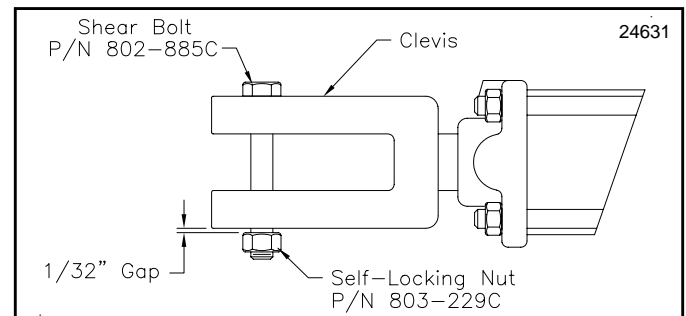

Shear Bolt Space

Figure 3-1

Replace shear bolt with correct replacement part (Land Pride Part No. 802-885C). A substitute shear bolt may result in damage to the parallel arms and/or main frame. A single replacement part is included with each cutter and is located on a bracket adjacent to the upper 3-point hitch.

IMPORTANT: Install self-locking nut onto shear bolt until nut is threaded to within approximately 1/32" of contact with clevis as shown in Figure 3-1.

Un-hooking the Rotary Cutter

The following steps should be done when un-hooking the cutter.

IMPORTANT: Make sure transport safety chain is attached to the Rotary Cutter deck and Float Switch, if available, is "OFF" before un-hooking the cutter.

1. Park on a level solid surface.
2. Lower cutter frame to level ground or onto blocks supporting the frame just above ground level.
3. Engage tractor park brake, shut tractor engine off and remove switch key before dismounting from tractor.
4. Unhook control stick from connector at the cutter and power source. Store control stick in a dry location.
5. Disconnect driveline from tractor PTO shaft.
6. Disconnect hoses from tractor duplex outlets.
7. Un-hook 3-point hitch from tractor. Reinstall hitch pins, linch pins and hair pin cotters in cutter hitch for storage.
8. See "Cutter Storage" on page 39 when cutter is not going to be used for a long time.

Section 3: Operating Procedures

General Operating Instructions

Upon arriving at the work site, shut-off tractor, set brakes, remove ignition key, and dismount to perform the following checks:

1. Remove and safely store away transport safety chain.
2. Verify that the PTO driveline is approximately level. Adjust the height of the lower 3-point arms if PTO driveline is not level.
3. Visually inspect cutter blades. Make certain they are not overlapped and locked together.

After performing the above checks, return to the tractor and start the engine. Extend cutter's parallel arms out and position the deck flat on the ground. Adjust cylinder height of the parallel arm and cutting deck for good visibility and unobstructed performance. Set engine rpm at idle or slightly above and engage PTO. Initial start-up vibration is normal and should smooth out after a few revolutions of the cutter blades unless the blades are locked. Shut off the PTO, raise the deck and inspect the blades if the deck continues to vibrate. Otherwise, increase tractor throttle PTO speed to 540 rpm for RCP2660 and RCP3060 series cutters and 1000 rpm for RCPM2660 and RCPM3060 series cutters. Proceed forward at a mowing speed that is comfortable and will produce a quality controlled cut for ground conditions and material density.

The Rotary Cutter is designed with automatic breakaway arms that release when the unit contacts immovable objects or irregular terrain. Arms must be reset to "home position" after each breakaway before cutting operations can resume. See "Breakaway Operating Procedures" on page 29".

For additional information on performance enhancing options, see "Section 8: Features & Benefits" on page 45 and "Section 7: Specifications & Capacities" on page 43.

It requires patience, practice, and attention to detail to become an expert operator of your Land Pride Parallel Arm Rotary Cutter. The end result is well worth the effort.

Section 4: Optional Equipment

Hydraulic Control Options

There are four options available.

Solenoid Control with Standard Deck Option:

Cutting deck is supplied without gauge wheels. Two duplex outlets are required to operate arm cylinders, deck pivot cylinder and breakaway cylinder. Arm and deck cylinders are solenoid activated with momentary push button switches at the control stick. Breakaway cylinder is controlled by tractor lever.

Tractor Control with Standard Deck Option:

Cutting deck is supplied without gauge wheels. Four tractor duplex outlets are required to operate the arm cylinders, deck pivot cylinder and breakaway cylinder. Tractor levers operator all cylinders.

Solenoid Control with Valve Float Deck Option:

Cutting deck is supplied with gauge wheels for controlling deck height and angle in lieu of momentary push button switches. Two duplex outlets are required to operate arm cylinders, deck pivot cylinder and breakaway cylinder. Arm and deck cylinders are solenoid activated with momentary push button switches at the control stick. An "ON/OFF" push button Float Switch is included on the control stick to bypass "ARM 2" and "DECK" solenoids allowing the deck to float on its gauge wheels. Breakaway cylinder is controlled by tractor lever.

Tractor Control with Hose Float Deck Option:

Cutting deck is supplied with gauge wheels for controlling deck height and angle in lieu of control levers. Four duplex outlets are required at the tractor to operate the arm cylinders, deck pivot cylinder and breakaway cylinder. Tractor levers operator all cylinders. "ARM 2" and "DECK" control levers are set in float position when carrying the deck on its gauge wheels.

Operator Protective Shield Option

An optional operator protective shield is available for use on tractors not equipped with cabs or other protective shielding. This shield is a "universal" type and is suitable for attachment to a conventional Roll Over Protective Structure (ROPS) that is already attached to the tractor. It is constructed of an extruded aluminum frame and glazed with 1/4" clear lexan polycarbonate.

Mounting hardware will permit attachment to ROPS having cross-section dimensions of 2" x 4", 2" x 5", and 2" x 6" or 2 1/2" x 4", 2 1/2" x 5" and 2 1/2" x 6". Other sizes may require longer mounting bolts and/or custom flatbars. Installation requires that 4 mounting holes be drilled in the frame of the shield. No modification is made to the ROPS.

Operator Protective Shield Option 316-063A

Protective Shield Installation

Refer to Figure 4-1:

1. Measure width and thickness of the tractor ROPS bar to determine if the clamping hardware supplied will be adequate.
2. Compare parts list and quantities with parts received. Report any missing or damaged items to your dealer.

NOTE: To determine the best location for the protective shield, the cutter should be connected to the tractor, parallel arms should be fully extended and the deck should be approximately horizontally level.

3. Carefully remove the shield from the shipping carton and temporarily position it on the inside surface of the ROPS bar. Locate shield forward/back and up/down to provide the best overall coverage for the tractor operator. Use a spirit level to level the shield before marking. Mark frame location with a pencil on each side of the ROPS bar; and mark vertical ROPS location on the shield frame.
4. Position protective shield (#5) on a flat work surface. Locate one of the flatbars (#4) next to the pencil marks to determine which set of holes will clear the vertical marks for the ROPS location. Mark hole location and drill two 1/4" diameter holes through the shield frame. Similarly mark and drill two additional holes for the lower clamp location.
5. Attach shield to the inside surface of the ROPS bar with 1/4" x 4" cap screw (#6), 1/4" flat washer (#3), 1/4" lockwasher (#2) and 1/4" nut (#6).

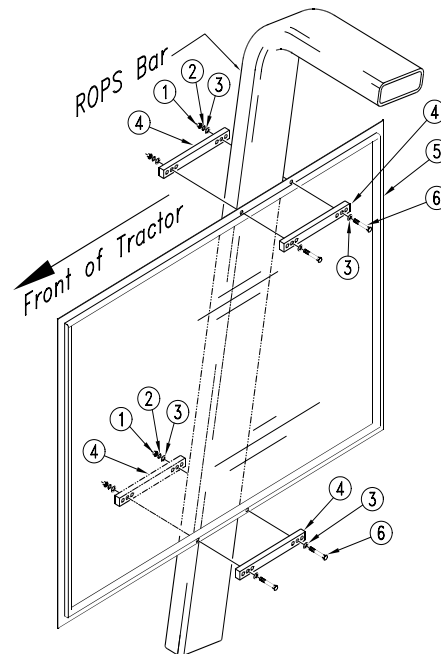

**Operator Protective Shield
Figure 4-1**

13239

Section 5: Hydraulic Plumbing

Hydraulic Plumbing Without Solenoid

Refer to Figure 5-1:

The standard **Parallel Arm Cutter** is equipped with three (3) remote cylinders to operate the parallel arms and

deck. These cylinders are connected directly to the tractor's remote duplex outlets and are controlled by tractor operator. Each cylinder requires a duplex outlet at the tractor.

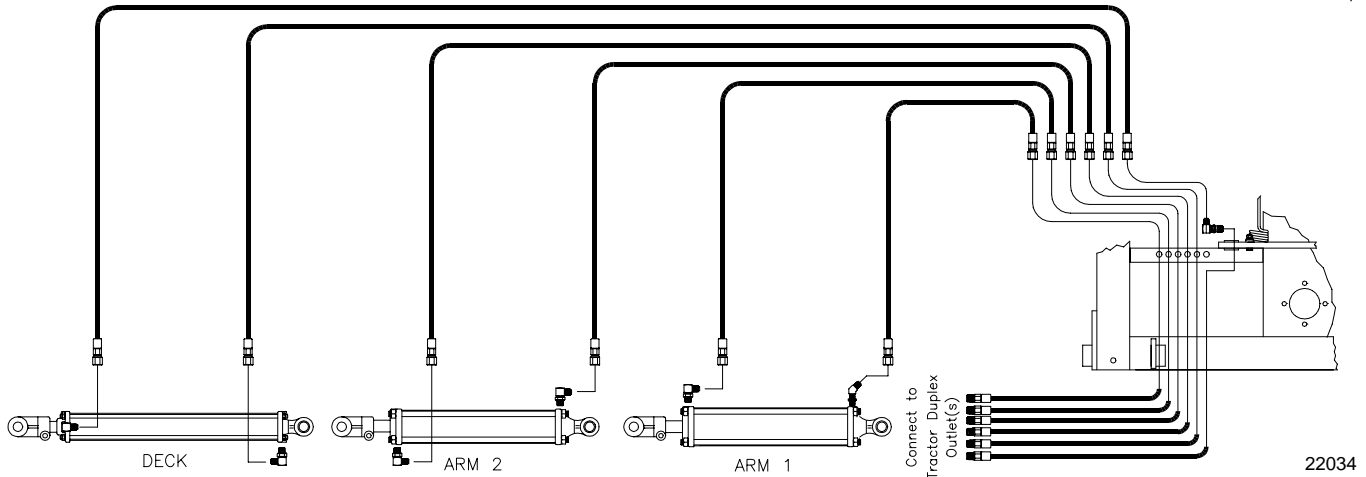

Remote Cylinder Plumbing without Solenoid Control box
Figure 5-1

Hydraulic Plumbing With Solenoid

Refer to Figure 2-1 on page 25 and Figure 5-2 on this page.

IMPORTANT: The flow control valve must be plumbed correctly. See "Tractors Rated at 15 GPM and Under" on page 16 and "Tractors Rated at 16 GPM and Above" on page 16.

The solenoid controlled cylinders provide for momentary push button switch operation of each cylinder. These cylinders are connected directly to the solenoid control box. Two hydraulic hoses are connected directly to one of the tractor's remote duplex outlets. The hydraulic cylinders are then controlled by an electrical control stick with push button switches on the tractor near the operator.

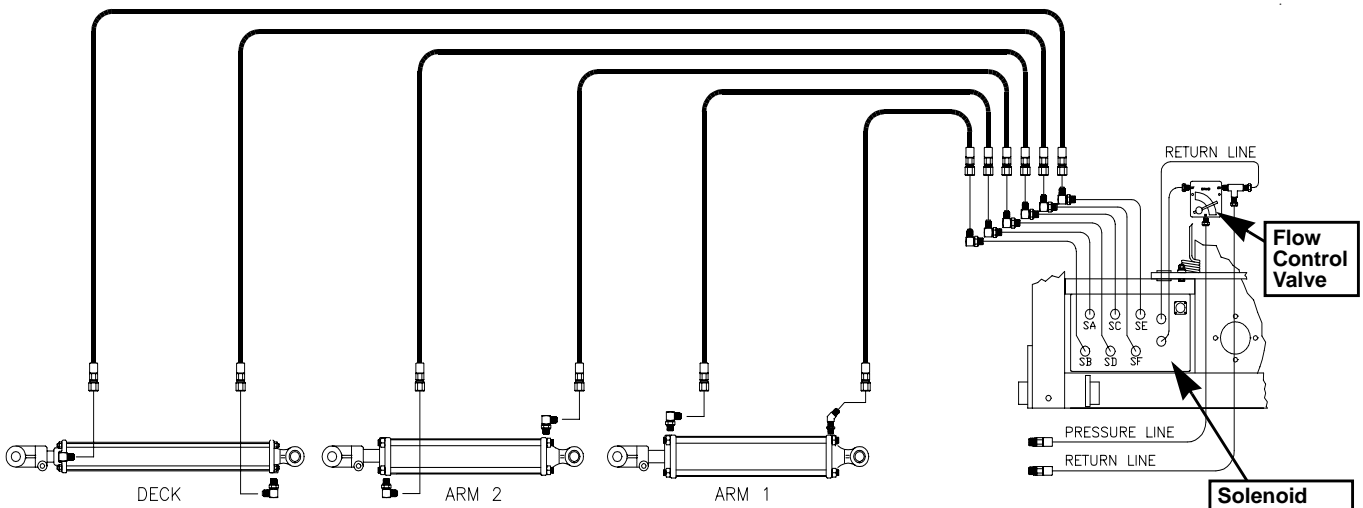

The flow control valve must be plumbed correctly. See "Tractors Rated at 15 GPM and Under" on page 16 and "Tractors Rated at 16 GPM and Above" on page 16.

Remote Plumbing with Solenoid Control box
Figure 5-2

Section 5: Hydraulic Plumbing

Wiring Schematic (Without Float Switch)

Refer to Figure 5-3:

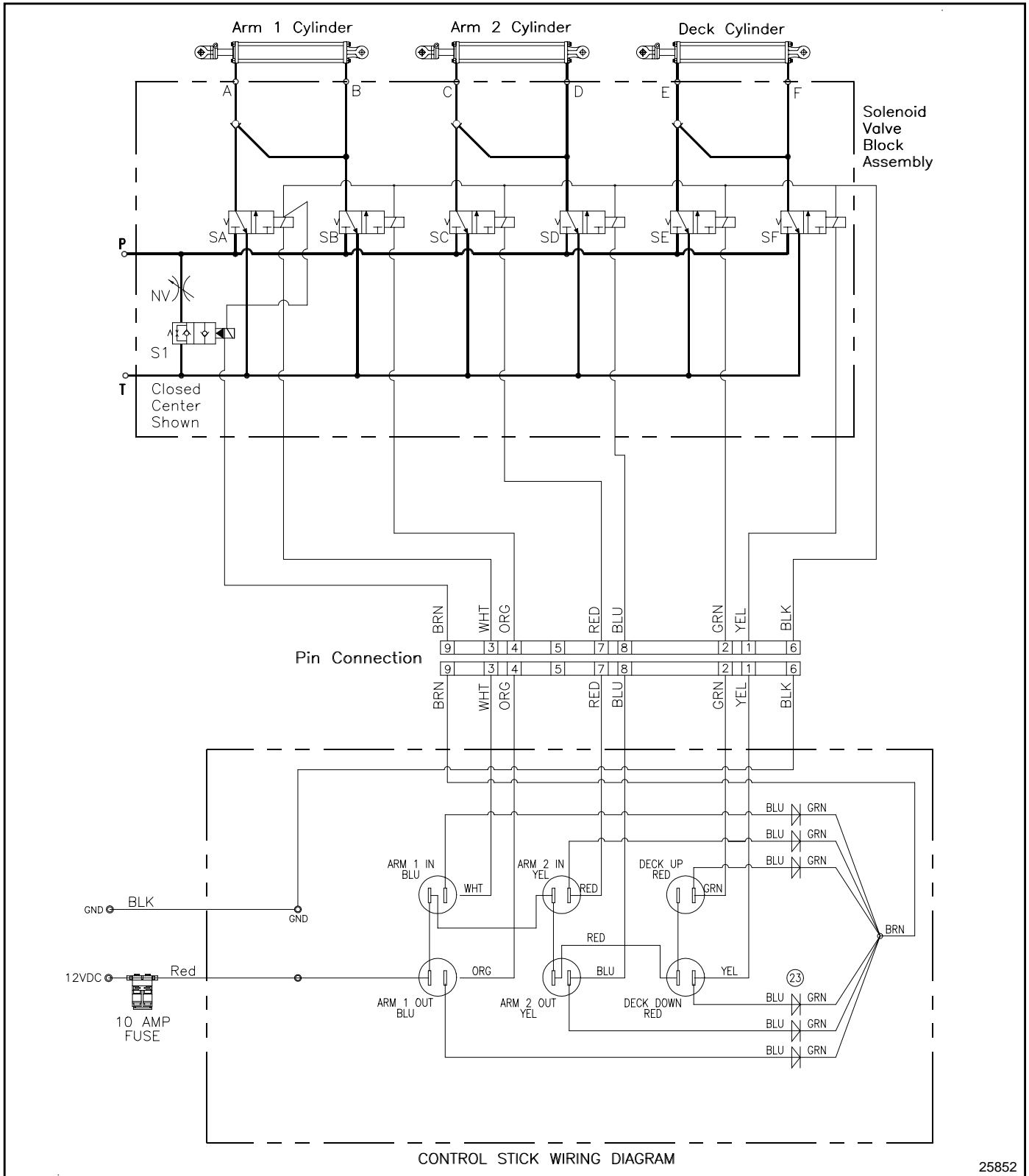

25852

Schematic of Solenoid Controlled Cylinders and Control Stick Without Float Switch
Figure 5-3

Section 5: Hydraulic Plumbing

Wiring Schematic (With Float Switch)

Refer to Figure 5-4:

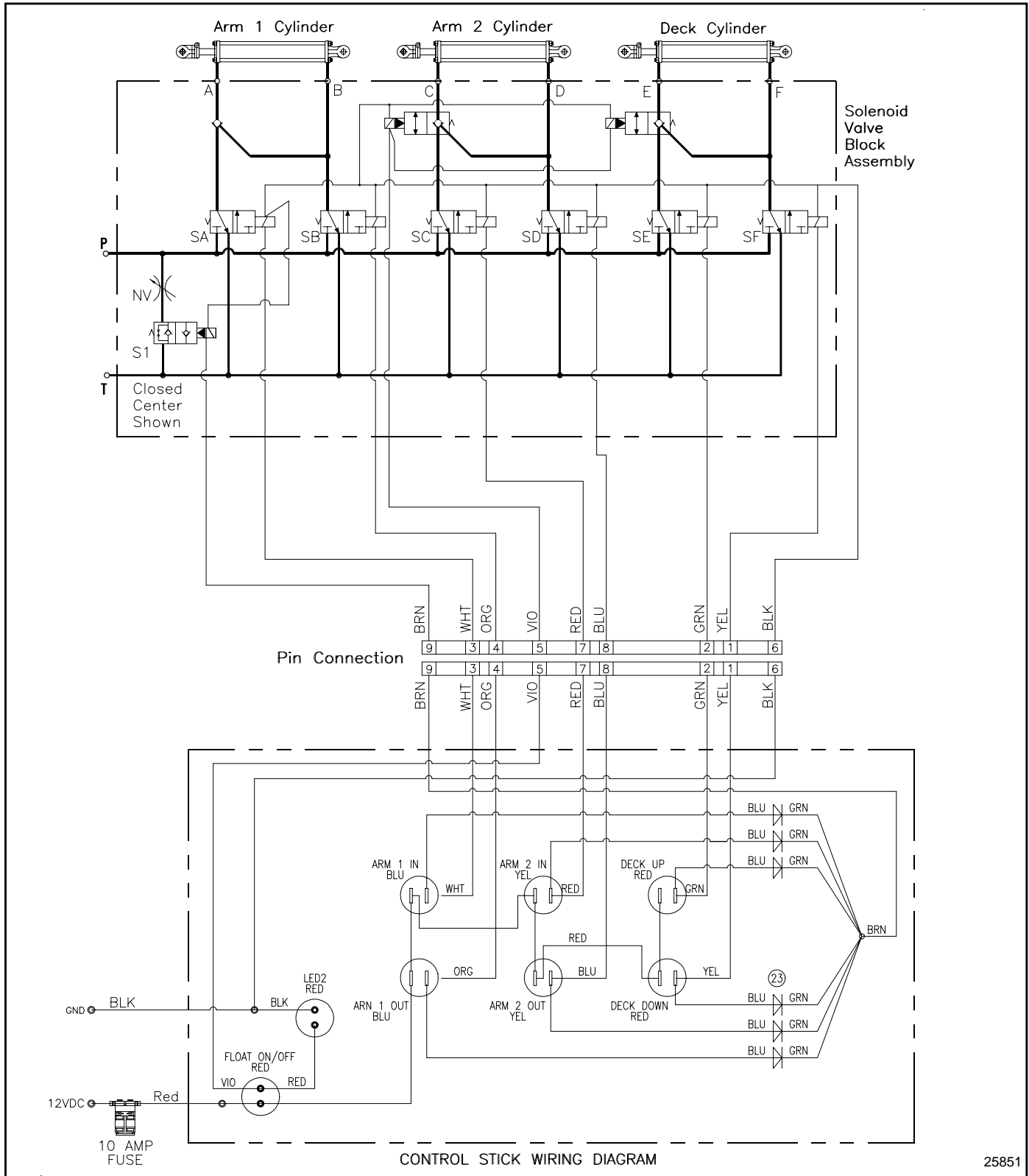

Schematic of Solenoid Controlled Cylinders and Control Stick With Float Switch
Figure 5-4

Section 5: Hydraulic Plumbing

Pump & Motor Plumbing

Refer to Figure 5-5:

The hydraulic pump and motor are powered by tractor driven PTO and are not connected to tractor hydraulics.

The pump receives fluid from a 35 gallon reservoir. If cutter blades are stalled, an overpressure relief valve opens to provide a return path to the reservoir. Make certain the hydraulic reservoir shut-off valve is fully open before operating pump and motor drive.

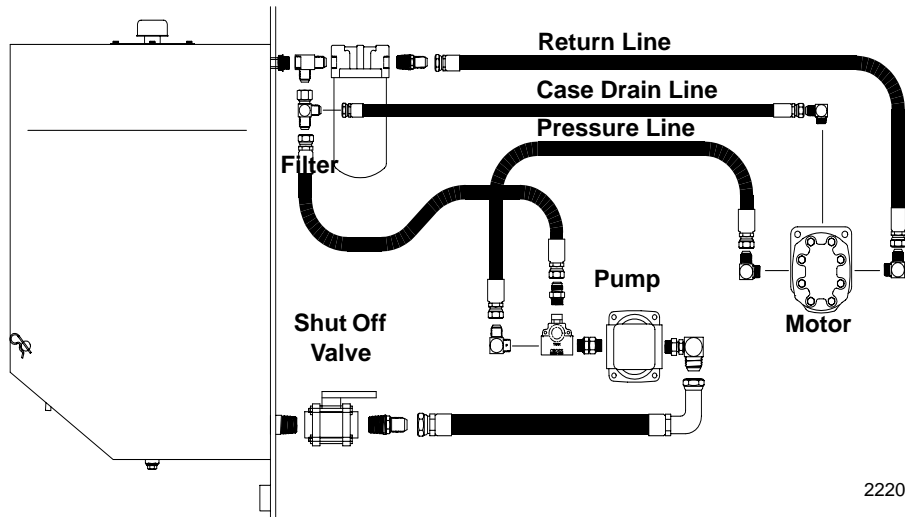

22207

Hydraulic Pump Motor Circuit
Figure 5-5

Marking Hydraulic Lines

From Motor to Pump and Pump to Motor
Refer to Figure 5-6:

Replacement hydraulic hoses should be measured and marked before installing to the parallel arm. Install each hose with the mark located on the parallel arm in the positions shown in Figure 5-6.

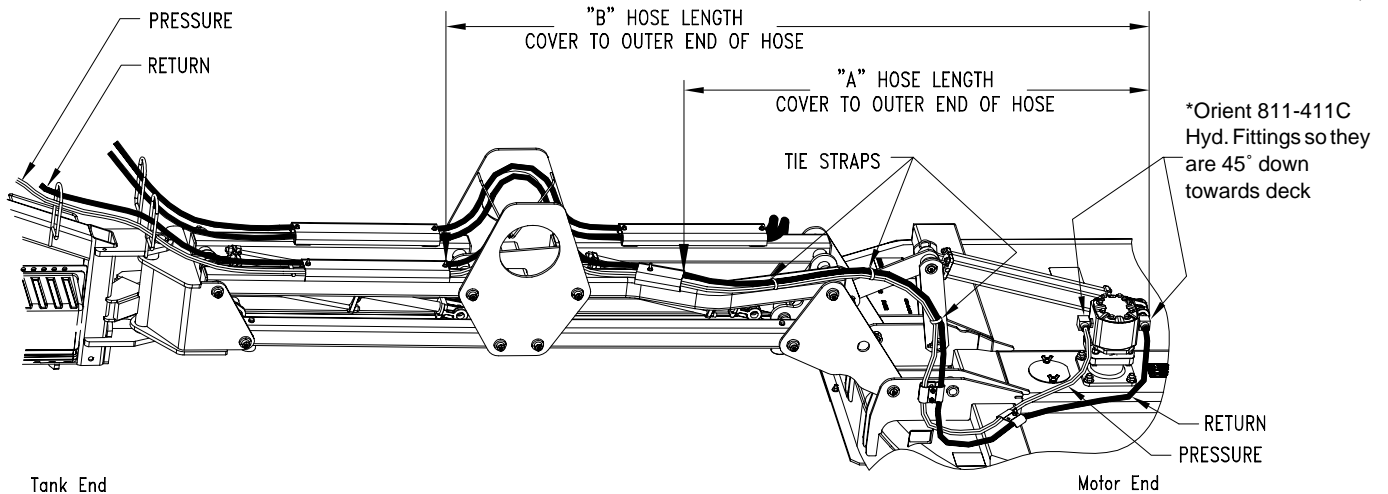

Tank End

Motor End

Mark Hydraulic Hoses at Locations Shown Below

"A" {	RETURN	83 1/4"	} From Outer End of Hose To Visible Edge of Hose Cover
	PRESSURE	74 3/4"	
"B" {	RETURN	RCP(M)2660 138 1/2"	} From Outer End of Hose To Visible Edge of Hose Cover
	PRESSURE	RCP(M)3060 130" 157 1/2" 149"	

**Twist return hose (811-404C) counter-clockwise until it follows the same contour as pressure hose (811-403C).

22001

Hose Locations for Hydraulic Pump and Motor
Figure 5-6

Section 5: Hydraulic Plumbing

Breakaway Cylinder Plumbing

Refer to Figure 5-7:

CAUTION

The breakaway cylinder is designed to bypass hydraulic fluid under high pressure when cutter head or parallel arms strike an object during forward movement. **Do not** use any standard hydraulic cylinder for a breakaway cylinder or damage could occur to the unit.

The breakaway cylinder is used to prevent structural damage to the cutter head and parallel arms. If the cutter head strikes an object during forward movement, the breakaway cylinder extends - allowing the parallel arms and cutter deck to freely pivot 90 degrees to the rear.

IMPORTANT: A 1/2" bolt is installed for shipping purposes only. This **bolt must be remove** before connecting the hydraulic hoses to the tractor.

The breakaway cylinder should be installed on the cutter as shown in Figure 5-7. Be sure the rod end of the

cylinder is located on pivot lug as shown. Connect both hoses from cylinder to a remote duplex outlet on the tractor.

Pressure Shut Down Valve Operation

Refer to Figure 5-7:

The standard pressure shut down valves supplied with the breakaway cylinder inherently leak a small amount of oil allowing the deck to drift back during field operation. When required, reset the cutter deck forward during field operation using the tractor's remote cylinder control levers.

An optional replacement pressure shut down valve is available that greatly reduces the frequency of cutter bar drift but takes continuous force to move the deck back. **(Deck does not freely pivot back as it does when using the standard pressure shut down valves).**

See Land Pride's Parts Manual No. 316-111P for ordering either the standard or optional pressure shut down valves. Order only genuine Land Parts from your local Land Pride Dealer.

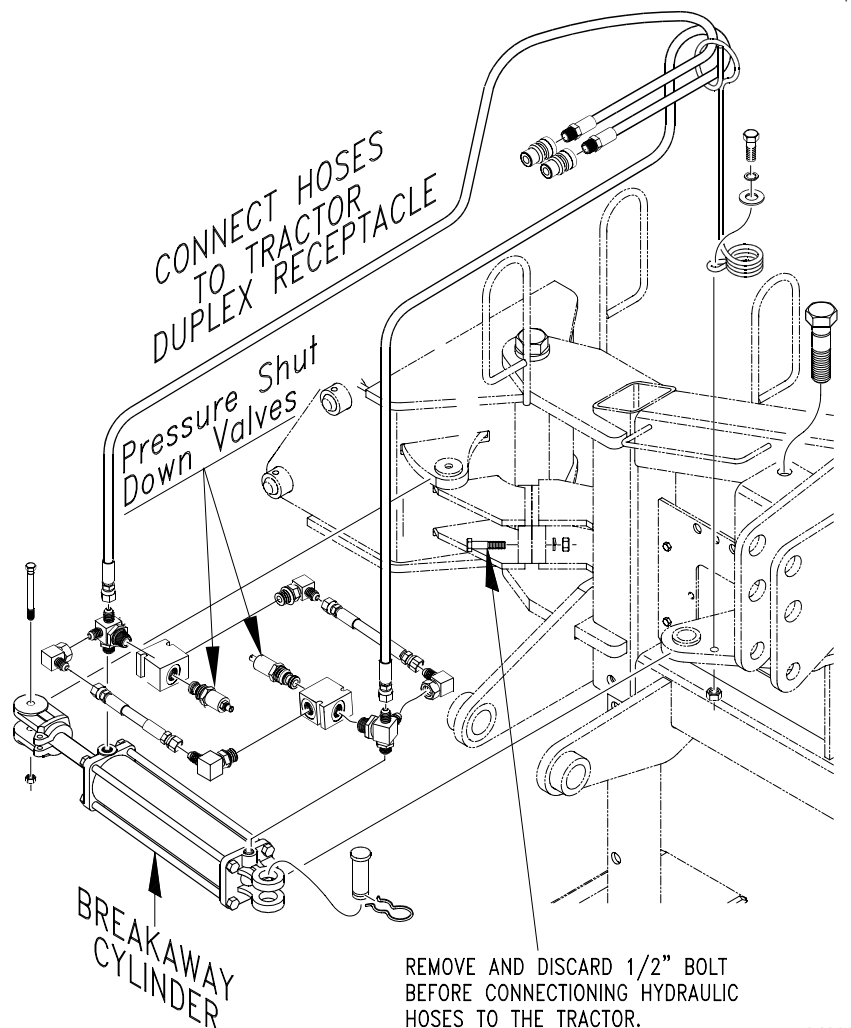

24633

Breakaway Cylinder Installation
Figure 5-7

Section 6: Maintenance & Lubrication

Maintenance

Proper servicing and adjustment is the key to the long life of any implement. With careful and systematic inspection, you can avoid costly maintenance, time and repair.

After using your Rotary Cutter for several hours, check all bolts to be sure they are tight.

Replace any worn, damaged or illegible safety labels by obtaining new labels from your Land Pride Dealer.

Cutter Blades



WARNING

Always secure cutter deck in the up position with solid supports before servicing underside of deck. Never work under equipment supported by hydraulic jacks. Hydraulic jacks can drop equipment if controls are actuated or if hydraulic lines burst. Either situation can drop the cutter instantly even when power to the hydraulic system is shut off.



DANGER

Always disconnect main driveline from tractor PTO before servicing underside of deck. Cutter can be engaged if tractor is started resulting in damage to the cutter, bodily injury and/or death.

Always inspect cutting blades before each use. Make certain they are properly installed and are in good working condition. Replace any blade that is damaged, worn, bent, or excessively nicked. Small nicks can be ground out when sharpening.

IMPORTANT: Replace cutting blades with genuine Land Pride blades only. Blades must be replaced in mating pairs. Not replacing both blades will result in an out-of-balance condition that will contribute to premature bearing break down on the spindle hub and create structural cracks in cutter housing. Factory blades are 4" wide by 25" long.

1. Align blade bolt (#1 in Figure 6-2) with blade bolt access hole shown in Figure 6-1.
2. Place tractor gear selector in park and/or set brakes, shut engine off and remove ignition key.
3. Disconnect main driveline from tractor PTO and secure cutter deck in the up position with solid supports before servicing underside of cutter.
4. Inspect cutting blades. Make certain they are properly installed and are in good working condition. Replace any blade that is damaged, worn, bent, or excessively nicked. Small nicks can be ground out when sharpened.

5. Both blades should be sharpened at the same angle as the original cutting edge and must be replaced or re-ground at the same time to maintain proper balance. The following precautions should be taken when sharpening blades:
 - a. Do not remove more material than necessary.
 - b. Do not heat and pound out a cutting edge.
 - c. Do not grind blades to a razor edge. Leave a blunt cutting edge approximately 1/16" thick.
 - d. Always grind cutting edge so end of blade remains square to cutting edge and not rounded.
 - e. Do not sharpen back side of blade.
 - f. Both blades should weigh the same after sharpening with not more than 1 1/2 oz. difference.

Refer to Figure 6-1:

6. Carefully check cutting edges of blades in relation to blade carrier rotation to ensure correct blade placement. Blade Rotation is clockwise with cutting edge leading. Airfoil (lift) must be oriented towards the top of the deck.

BLADE ROTATION

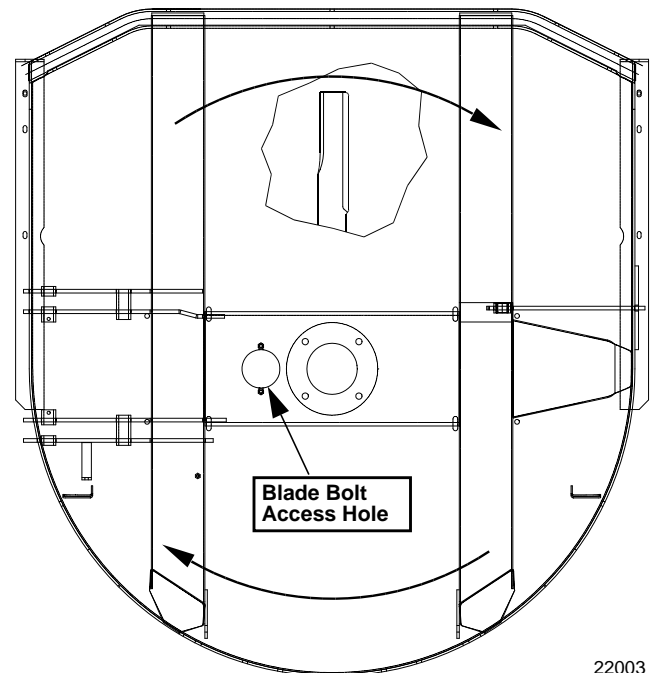

22003

Blade Rotation
Figure 6-1

Section 6: Maintenance & Lubrication

Refer to Figure 6-2:

IMPORTANT: Examine blade bolts (#1) and washers (#5) for excessive wear and replace if worn.

IMPORTANT: Locknuts can lose their ability to lock properly once removed. Therefore, always use a used blade nut or plain nut in steps step 7 & step 8 below and then **replace used nut with new locknut in step step 9.**

7. Start by assembling blades without shim (#2). Insert blade bolt (#1) through blade (#3), dish pan (#4) and flat washer (#5). Temporary secure blade with a used 1 1/8"-12 nut. **Draw nut up snug. Do not tighten.**
8. Check blade deflection. If deflection is greater than 3/4", remove blade bolt and reassemble as before except include shim (#2) in the assembly. Select shim thickness based on deflection. The greater the deflection, the thicker the shim.
9. Once blade deflection is correct, **replace used nut with new locknut (#6)** and torque to 450 ft. lbs.
10. If replacing dishpan (#4), nut on gearbox output shaft should be torqued to 550 ft./lbs. and cotter pin installed in nut with legs securely bent around nut.

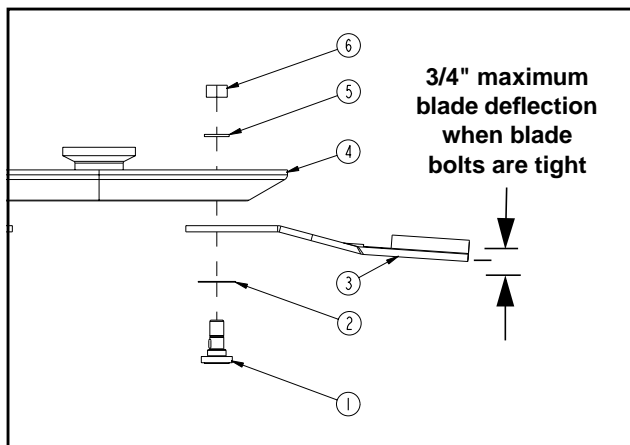

Cutter Blade Assembly
Figure 6-2

Land Pride Cutter Blade Parts

Item	Part No.	Part Description
	318-586A	BLADE BOLT KIT (Includes items 1, 2, 5, & 6 below)
1	802-277C	BLADE BOLT 1 1/8-12 x 3 7/16 WITH KEY
2	312-075D	BLADE SPACER 16 GA. (.060")
2	312-082D	BLADE SPACER 18 GA. (.048")
2	312-089D	BLADE SPACER 20 GA. (.036")
2	312-808D	BLADE SPACER 24 GA. (.024")
3	820-112C	CUTTER BLADE 1/2 x 4 x 25 CW
4	316-124H	DISHPAN WELDMENT SPCL-HUB
5	804-147C	WASHER FLAT 1 HARD ASTM F436
6	803-170C	NUT HEX TOP LOCK 1 1/8-12 PLATE

Skid Shoes

WARNING

Excessive wear on skid shoes may cause inadequate operation of cutter and create a safety hazard!

Inspect skid shoes at the beginning of each cutting season. Check all skid shoes weekly for wear and replace if necessary. Original material thickness is 1/4". They should be replaced when the material thickness is less than 1/8" at any point. They are interchangeable from left to right.

Order only genuine Land Pride parts from your local Land Pride Dealer.

Land Pride Skid Shoe Replacement Parts

Part No.	Part Description
312-602D	SKID SHOE
802-466C	PLOW BOLT, 3/8" - 16 x 1 1/4" grade 5

Refer to Figure 6-3:

Replace wing skid shoes as follows:

1. Remove 3/8" hex whiz nuts (#3), 3/8" plow bolts (#2) and skid shoe (#1) as shown.
2. Plow bolts should be checked for wear and replaced if necessary.
3. Attach new skid shoe (#1) to cutter with existing 3/8" plow bolts (#2) and secure with 3/8" hex whiz nuts. Torque to 31 ft. lbs.
4. Repeat on opposite side.

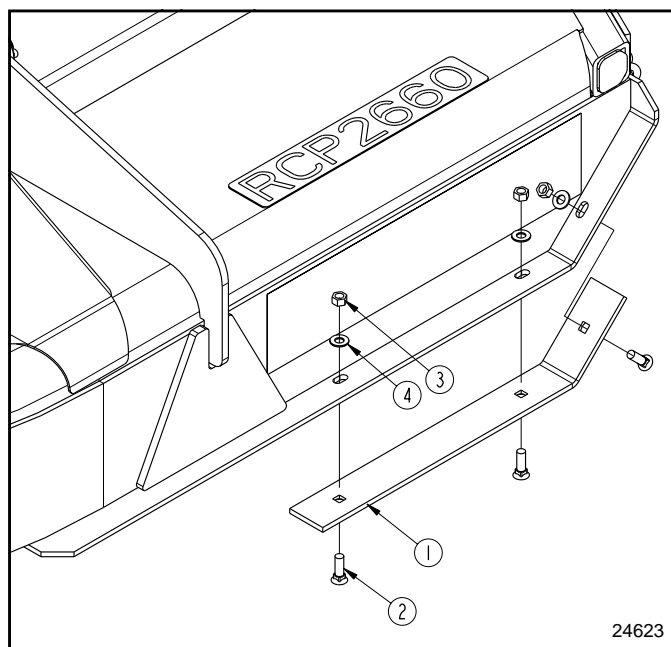

Wing Skid shoe
Figure 6-3

Section 6: Maintenance & Lubrication

Solenoid Valve Block

Refer to Figure 6-4:

IMPORTANT: DO NOT exert more than 3 ft. lbs. of torque on the hex nut securing the solenoid armature. Remember, 3 ft. lbs. is slightly more than finger tight! Overtightening this nut will distort hollow armature shaft and may result in valve break down.

The 1/2" hex nut on the end of the solenoid armature shaft must be removed to remove a solenoid valve from the valve block. Use care when removing and replacing this nut. Do not tighten nut with more than 3 ft. lbs. of torque.

See your nearest Land Pride Dealer to purchase new solenoid valves and/or seal kits.

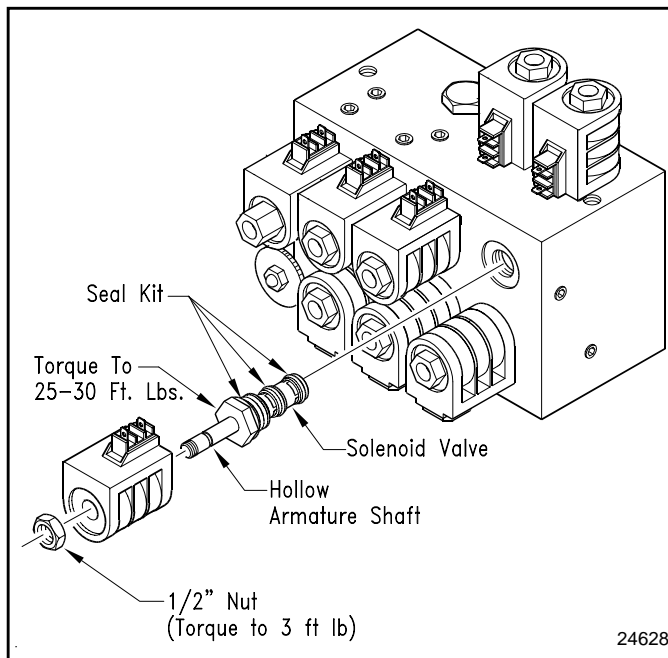

Solenoid Valve Block
Figure 6-4

Tractor Maintenance

One of the most important things you can do to prevent hydraulic system problems is to ensure that your tractor's reservoir remains free of dirt and contamination.

Use a clean cloth to wipe hose ends before attaching them to your tractor. Replace filter element for your tractor's hydraulic system at the prescribed intervals. These simple maintenances will go a long way to prevent the occurrence of solenoid valve and hydraulic cylinder problems on the Parallel Arm Cutter.

Cutter Storage

Clean the Rotary Cutter at the end of the working season or when the cutter will not be used for a long period.

1. Store control stick in a clean dry location. Do not leave it out in the rain. Clean control stick with a damp rag. Do not submerge control stick in water or clean with high pressure wash.
2. Clean off any dirt or grease that may have accumulated on the deck, gearbox and on any of the moving parts. Scrape off compacted dirt from the bottom of the deck and then wash the surface thoroughly with a garden hose. A coating of oil may also be applied to the lower deck area to minimize oxidation.
3. Check blades and blade bolts for wear and replace if necessary. See "**Section 6: Maintenance & Lubrication**" on page 37.
4. Inspect for loose, damaged or worn parts and adjust or replace as needed.
5. Lubricate as noted in "**Section 6: Maintenance & Lubrication**" on page 37.
6. Store the cutter in a clean, dry place. The deck should be positioned on a flat surface with arms retracted and the jack stands lowered to suitable 3-Point height. Ensure that the main frame is stable. Use auxiliary supports or posts if necessary to prevent the possibility of the unit tipping over.
7. Repaint parts where paint is worn or scratched to prevent rust. Aerosol Buckskin touch-up paint is available from your Land Pride Dealer.

Land Pride Touch-up Paint



Part No.	Part Description
821-011C	PAINT LP BEIGE SPRAY CAN
821-002C	PAINT GP BLACK SPRAY CAN

Section 6: Maintenance & Lubrication

Lubrication Points

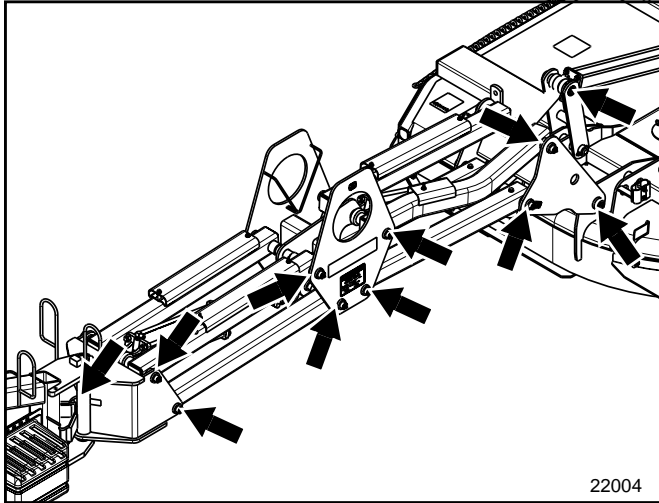
<p>Lubrication Legend</p>	 <p>Multi-purpose spray lube</p>	 <p>Multi-purpose grease lube</p>	 <p>Multi-purpose oil lube</p>	 <p>Intervals in hours at which lubrication is required</p>
----------------------------------	---	--	---	--

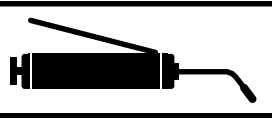



	
--	---

Parallel Arm

11 Zerks

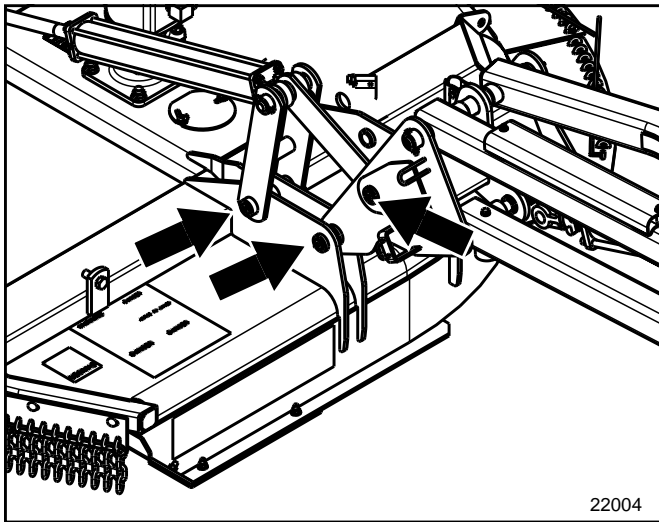
Type of Lubrication: Multi-purpose Grease

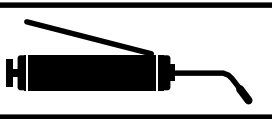



	
---	--

Deck Pivot

3 Zerks

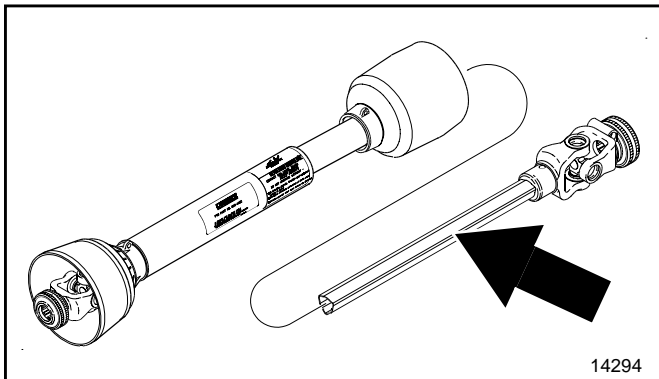
Type of Lubrication: Multi-purpose Grease

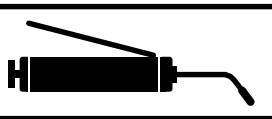

	
--	---

Driveline Profile

2 Zerks

Type of Lubrication: Multi-purpose Grease

Section 6: Maintenance & Lubrication

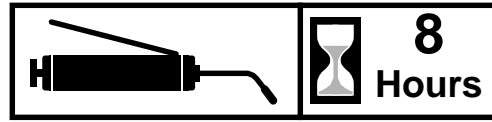
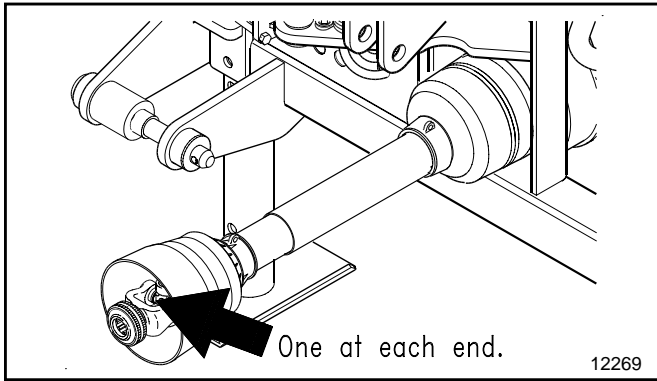

PTO U-joint

2 Zerks

Type of Lubrication: Multi-purpose Grease

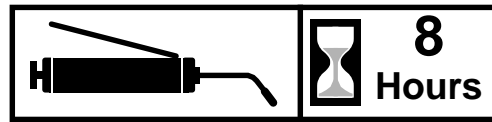
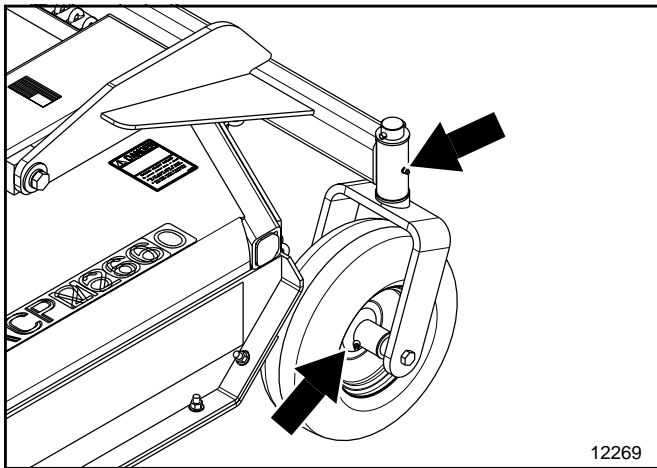

Gauge Wheel

2 Zerks per wheel (3- wheels)

Type of Lubrication: Multi-purpose Grease

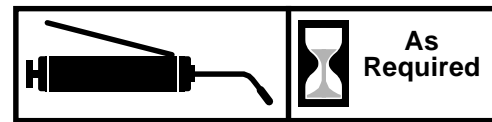
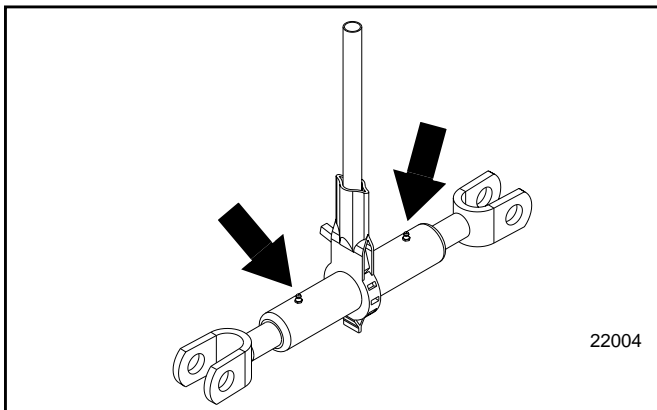

Ratchet Jack

2 Zerks per jack (2-jacks)

Type of Lubrication: Multi-purpose Grease

Quantity - As Required

Section 6: Maintenance & Lubrication

Motor Spindle Hub

Refer to Figure 6-5:

The motor spindle hub (#1), has two cavity plugs (#2) located on one side of the housing.

1. Disengage PTO driveline.
2. Position cutter deck in transport position and secure with deck safety chain.
3. Set tractor park brake, shut engine off and remove switch key before continuing.
4. Remove one of the cavity plugs (#2) to check fluid level. Fluid level should be within 1/2" from top of port opening.
5. Add 80-90 weight gearlube as required. Full capacity of motor housing is approximately 1/3 pint.
6. Install cavity plug and tighten.

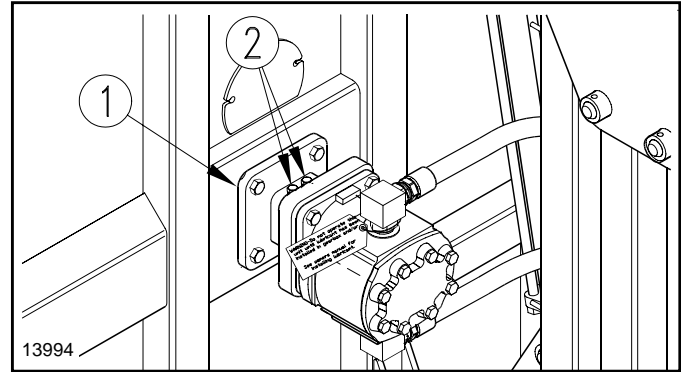

**Motor/Spindle Hub
Figure 6-5**

Hydraulic Reservoir

Refer to Figure 6-6:

The hydraulic reservoir has an effective capacity of 35 gallons. A dipstick located on the filler cap indicates correct reservoir fluid level. Disengage PTO driveline and shut tractor engine off before checking fluid level. Add hydraulic fluid as needed to fill to full mark on dipstick.

A filter mounted on the hydraulic reservoir is used to clean the return hydraulic fluid to the reservoir tank. Replace filter element ever 2 years with a conventional 10 micron filter.

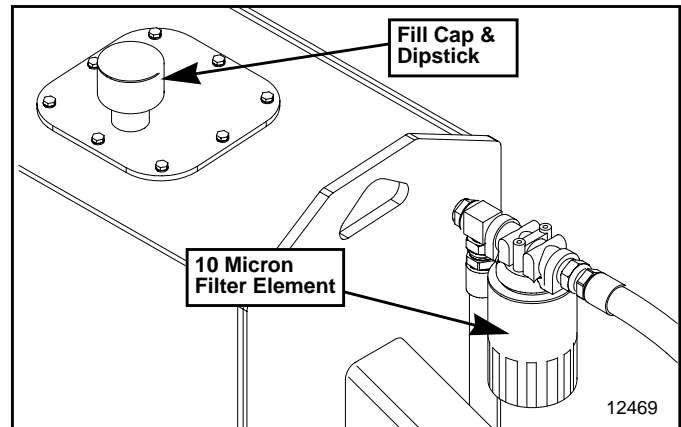

**Filter Removal
Figure 6-6**

Speed In increaser

Refer to Figure 6-7:

The speed increaser is mounted between the PTO driveline and hydraulic pump. It is used to increase PTO speed from 540 rpm or 1000 rpm to approximately 2000 rpm at the pump.

Check oil level by removing level plug located on the gearbox side. Oil level should be level with bottom of plug hole. Add oil if low through the breather/fill cap opening.

Change oil after the first 100 working hours. Make successive changes every 1500 hours thereafter or every year, whichever comes first. Drain old oil out through the drain plug hole located at the bottom. Be sure to reinstall drain plug and tighten before filling gearbox. Fill gearbox with 80-90W EP gearlube. Reinstall level plug and tighten. Replace breather/fill cap.

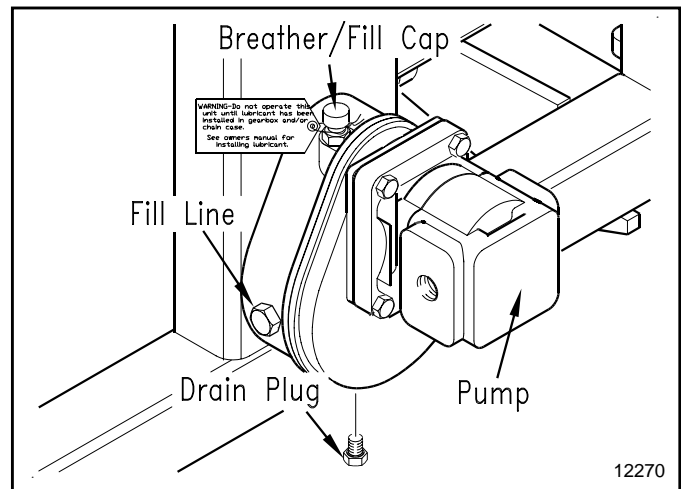

**Speed In increaser
Figure 6-7**

Section 7: Specifications & Capacities

RCP(M)2660 & RCP(M)3060 Series (Parallel Arm)

	RCP2660	RCPM2660	RCP3060	RCPM3060
PTO Input Speed	540 RPM	1000 RPM	540 RPM	1000 RPM
Deck Motor RPM	1000 RPM @ 540	1000 RPM @ 1000	1000 RPM @ 540	1000 RPM @ 1000
Minimum Tractor Horsepower	75 HP		95 HP	
Minimum Base Tractor Weight	8,000 Lbs. without added weights		12,000 Lbs. without added weights	
Weight	1,690 lbs (No fluid and without gauge wheels)		2,225 lbs (No fluid and without gauge wheels)	
Cutting Width	58"		58"	
Overall Width (Fully Extended)	19'-8"		22'-10"	
Transport Width	10' (without gauge wheels)		10' (without gauge wheels)	
Minimum Cutting Height (Deck Level)	2"		2"	
Maximum Horizontal Reach from Center Tractor	15'-6" (186")		18'-10" (226")	
Maximum Vertical Reach (Above Horizontal)	11'-5" (137")		13'-5" (161")	
Maximum Vertical Reach (Below Horizontal)	9'-1" (109")		11'-0" (132")	
Deck Rotating Arc	180 Degrees			
Blade Tip Speed	15,000 FPM			
Blade Size	1/2" x 4"			
Blade Rotation	Clockwise			
Blade Bolt	1 1/2" With keyway; nut			
Dishpan	3/16" X 21" Round, dish shaped			
Cutting Capacity	2" Max.			
Deck Thickness	10 GA			
Speed Inserter Fluid	80-90W EP Gearlube			
Hydraulic Fluid	Mobil 424			
Reservoir Capacity and Filter	35 Gallons / Conventional 10 Micron Filter			
Hydraulic Fluid Flow Rate	15 GPM (approx.)			
Overload Protection	Hydraulic relief valve			
Breakaway Protection	Hydraulic Cylinder			
Driveline	ASAE Category 2			
Hitch	3-Point Cat. 2 & 3 with clevis style lower hitch, Quick Hitch adaptable			
Skid Shoes	1/4" Reversible			
	Gauge Wheel Model			
Gauge Wheels	Three 13 x 5.00 - 6 Semi-solid smooth tires with greasable caged roller bearings.			
Height Adjustment	Two Ratchet jacks			
	Optional Equipment			
Options	Solenoid controlled cylinders			
	Tractor connecting hoses			
	Operator Protective shield			

Section 7: Specifications & Capacities

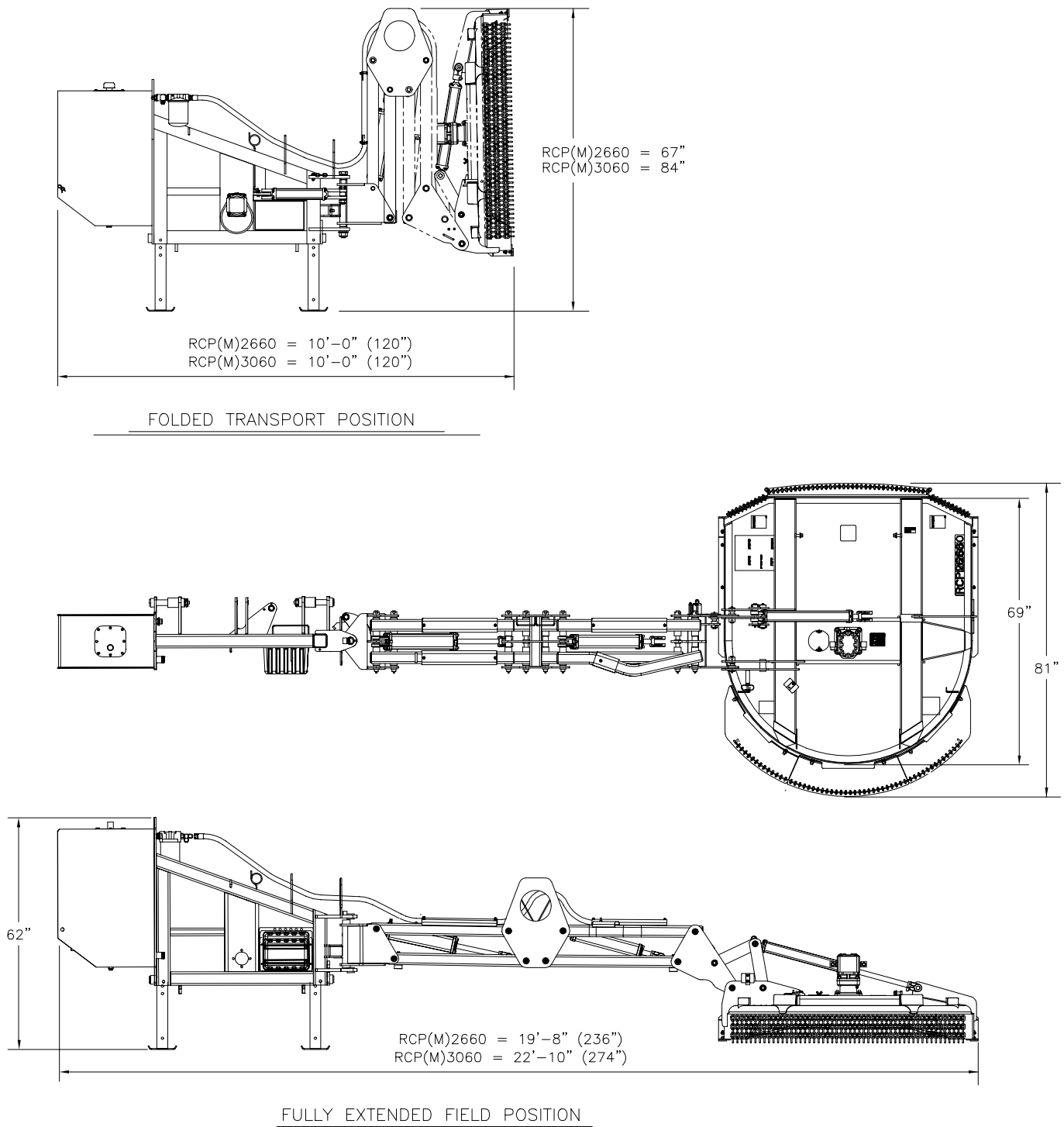

22005

Overall Dimensions
Figure 9-1

Section 8: Features & Benefits

RCP(M)2660 & RCP(M)3060 Series (Parallel Arm)

Features	Benefits
Tractor HP Range RCP(M)2660 RCP(M)3060	Designed for 75-150 HP tractor with minimum weight of 8,000 lbs. Designed for 95-175 HP tractor with minimum weight of 12,000 lbs.
Gearbox HP Rating	150 HP
3 Point Design	Does not tie up a tractor. Three point hook up is easy to hook up and remove from tractor.
Cutter Deck Visibility	Visibility of the cutter deck is captured from the operator's seat. Easy to see operation. Operator does not have to look behind.
Factory Assembled	Arrives ready for the customer, saves time and money. (Excluding fluids and hydraulic valve)
Grease Ports	All grease ports are easily accessible for servicing.
10' Transport Width	Folds up close to the tractor. No weight brackets or decks hanging away from the tractor. Typically, not much wider than the tractor, which means safer transporting.
Parallel Arm Design	Three cylinders used in a parallel arm design allows any cylinder to be adjusted without changing the position of the others. Means less positioning.
Long Horizontal Reach RCP(M)2660 = 15'-6" (186") RCP(M)3060 = 18'-10" (226")	Good access for reaching vegetation far away from the tractor. Better access for reaching vegetation far away from the tractor.
Above Grade Vertical Reach RCP(M)2660 = 11'-5" (137") RCP(M)3060 = 13'-5" (161")	Good access for reaching up embankments and cutting low over hanging limbs. Better access for reaching up embankments and cutting low over hanging limbs.
Below Grade Reach RCP(M)2660 = 9'-1" (109") RCP(M)3060 = 11'-0" (132")	Good access for reaching down embankments. Better access for reaching down embankments.
180 Degree Operating Tilt Arc	Cutter head can be positioned to reach different angles.
Cat. 2 & 3; 540 or 1000 RPM	Fits a wide variety of tractors.
35 Gallon Oil Reservoir	Large reservoir maintains optimum fluid temperatures and also serves as counterweight.
2" Cutting Capacity	Ideal for trimming brush.
High Blade Tip Speed	15,000 FPM tip speed means cleaner cutting.
Two Parking Stands	Easy and level storage, makes it easy for hooking to tractor.
In-line Filter	Cleans hydraulic fluid before it re-enters the reservoir.
Shut-off Valve	Permits maintenance with minimum oil loss.
Built-in Auxiliary Weight Rack on Left Side	Suitcase weights can be added to left side for balance.
Oil Pressure Gauge	Easily monitor oil pressure for optimum performance of unit.
Hydraulic Breakaway	Allows the parallel arms to pivot backwards to avoid obstacles and to protect cutter deck and parallel arms. Parallel arms are pivoted back to normal operating position with the hydraulic breakaway cylinder.
Flow Control Valve (Supplied with Solenoid Controlled Options)	Compensates for various tractor hydraulic systems so proper hydraulic fluid pressure can be maintained. (Used only with solenoid controlled cylinders.)
Solenoid Controlled Cylinders (Supplied with Solenoid Controlled Options)	Allows cutter to be used on tractors with only two hydraulic duplex outlets. Response time is faster than tractor controls making it an excellent choice when frequent changes to deck position are required.
Gauge Wheels (Supplied with Float Options)	Deck floats on gauge wheels eliminating frequent deck positioning and vigilant watch for changes in ground contour under the tractor and deck.



Troubleshooting Chart

Problem	Cause	Solution
Motor Oil Seal Leaking	Return line from motor has been pinched or is collapsed	Replace lower seal of motor. Check motor return hose for kinks.
Spindle Hub Seal Leaking	Return line from motor has been pinched or is collapsed	Replace lower seal of motor and Spindle Hub output shaft seal. Check motor return hose for kinks.
PTO driveline is bent. (NOTE: PTO tractor hitch shaft should be repaired or replaced if bent)	Contacting drawbar or Bottoming out	Reposition drawbar/Replace PTO tubes and cut to correct length.
Blades wearing excessively	Cutting on sandy ground	Raise cutting height.
	Contacting ground frequently	Raise cutting height.
Blades coming loose	Insufficient shimming	Add shimming. See text.
	Blade bolts not tightened properly	Torque blade bolt nuts to 600 ft lbs.
Blades breaking	Hitting solid objects	Thoroughly check the cutting area BEFORE beginning to cut. Be alert during cutting.
Loose Blade Carrier	Worn Spindle Hub bearings.	Replace Spindle Hub bearings and/or shaft.
	Shaft nut loose	Tighten Spindle Hub shaft nut to 450 ft lbs.
Blade Carrier bent	Hitting solid objects	Replace / Be alert, avoid solid objects.
Excessive skid shoe wear	Cutting height not level or blade missing	Adjust deck height or replace
	Soil abrasive	Raise cutting height.
	Cutting too low	Raise cutting height.
Excessive vibration	Locked blades	Inspect and unlock blades.
	Blades have unequal weight	Replace blades as a PAIR.
	PTO driveline is bent	Straighten or replace PTO driveline.
	Blade carrier bent	Replace/straighten blade carrier.
	PTO cross not centered with yoke	Disassemble and inspect for incorrectly located needles or damaged bearing cap.
Deck Cylinder will not extend and/or retract	Orifice elbow on rod end is plugged	Clean orifice fitting.
	Broken/disconnected wire on solenoid	Check wiring on cartridge valve solenoids.
Deck Cylinder will not retract	Cylinder rod is bent	Replace cylinder.
Arm/Deck Cylinder(s) will not extend and/or retract	Electric solenoid valve is sticking/dirty.	Remove solenoid valve and clean or replace.

Section 9: Troubleshooting

Problem	Cause	Solution
Electrical control push button switches do not work	10 AMP Fuse broken.	Replace 10 AMP fuse
	Circular Plastic connector is not connected to receptacle.	Connect remote cable to solenoid control valve.
	No power to control stick connections.	Check battery or power
	Tractor spool valve not engaged (open).	Lock tractor control valve open.
	Flow Control Valve not adjusted properly for open/closed center tractor	Adjust flow control valve
	Hoses not connected to proper duplex outlet on tractor	Connect hoses to proper tractor outlet.
	Defective solenoid on cartridge valve assy.	Replace solenoid.
	Solenoid valves is sticking.	Remove/clean/replace solenoid valve.
	Tractor hydraulic fluid level is too low.	Add fluid to tractor reservoir.

Torque Values Chart													
Bolt Size (Inches)	Bolt Head Identification						Bolt Size (Metric)	Bolt Head Identification					
	Grade 2		Grade 5		Grade 8			Class 5.8		Class 8.8		Class 10.9	
in-tpi ¹	N · m	ft-lb ³	N · m	ft-lb	N · m	ft-lb	mm x pitch	N · m	ft-lb	N · m	ft-lb	N · m	ft-lb
1/4" - 20	7.4	5.6	11	8	16	12	M 5 X 0.8	4	3	6	5	9	7
1/4" - 28	8.5	6	13	10	18	14	M 6 X 1	7	5	11	8	15	11
5/16" - 18	15	11	24	17	33	25	M 8 X 1.25	17	12	26	19	36	27
5/16" - 24	17	13	26	19	37	27	M 8 X 1	18	13	28	21	39	29
3/8" - 16	27	20	42	31	59	44	M10 X 1.5	33	24	52	39	72	53
3/8" - 24	31	22	47	35	67	49	M10 X 0.75	39	29	61	45	85	62
7/16" - 14	43	32	67	49	95	70	M12 X 1.75	58	42	91	67	125	93
7/16" - 20	49	36	75	55	105	78	M12 X 1.5	60	44	95	70	130	97
1/2" - 13	66	49	105	76	145	105	M12 X 1	90	66	105	77	145	105
1/2" - 20	75	55	115	85	165	120	M14 X 2	92	68	145	105	200	150
9/16" - 12	95	70	150	110	210	155	M14 X 1.5	99	73	155	115	215	160
9/16" - 18	105	79	165	120	235	170	M16 X 2	145	105	225	165	315	230
5/8" - 11	130	97	205	150	285	210	M16 X 1.5	155	115	240	180	335	245
5/8" - 18	150	110	230	170	325	240	M18 X 2.5	195	145	310	230	405	300
3/4" - 10	235	170	360	265	510	375	M18 X 1.5	220	165	350	260	485	355
3/4" - 16	260	190	405	295	570	420	M20 X 2.5	280	205	440	325	610	450
7/8" - 9	225	165	585	430	820	605	M20 X 1.5	310	230	650	480	900	665
7/8" - 14	250	185	640	475	905	670	M24 X 3	480	355	760	560	1050	780
1" - 8	340	250	875	645	1230	910	M24 X 2	525	390	830	610	1150	845
1" - 12	370	275	955	705	1350	995	M30 X 3.5	960	705	1510	1120	2100	1550
1-1/8" - 7	480	355	1080	795	1750	1290	M30 X 2	1060	785	1680	1240	2320	1710
1 1/8" - 12	540	395	1210	890	1960	1440	M36 X 3.5	1730	1270	2650	1950	3660	2700
1 1/4" - 7	680	500	1520	1120	2460	1820	M36 X 2	1880	1380	2960	2190	4100	3220
1 1/4" - 12	750	555	1680	1240	2730	2010							
1 3/8" - 6	890	655	1990	1470	3230	2380							
1 3/8" - 12	1010	745	2270	1670	3680	2710							
1 1/2" - 6	1180	870	2640	1950	4290	3160							
1 1/2" - 12	1330	980	2970	2190	4820	3560							

¹ in-tpi = nominal thread diameter in inches-threads per
² N · m = newton-meters
³ ft-lb = foot pounds
⁴ mm x pitch = nominal thread diameter in millimeters x thread pitch

Torque tolerance + 0%, -15% of torquing values. Unless otherwise specified use torque values listed above.

Additional Torque Values	
Blade Bolt Lock Nut	450 ft-lbs
Blade Carrier Hub Nut	450 ft-lbs

Warranty

Land Pride warrants to the original purchaser that this Land Pride product will be free from defects in material and workmanship beginning on the date of purchase by the end user according to the following schedule when used as intended and under normal service and conditions for personal use.

Overall Unit and Driveline: One year Parts and Labor

Hydraulic Cylinder: One year Parts and Labor.

Hoses and seals are considered wear items.

Hydraulic Motor: Two years Parts and Labor.

Solenoid Control Valves: One year Parts and Labor.

This Warranty is limited to the replacement of any defective part by Land Pride and the installation by the dealer of any such replacement part, and does not cover common wear items such as blades, belts, tines, etc. Land Pride reserves the right to inspect any equipment or parts which are claimed to have been defective in material or workmanship.

This Warranty does not apply to any part or product which in Land Pride's judgment shall have been misused or damaged by accident or lack of normal maintenance or care, or which has been repaired or altered in a way which adversely affects its performance or reliability, or which has been used for a purpose for which the product is not designed. Misuse also specifically includes failure to properly maintain oil levels, grease points, and driveline shafts.

Claims under this Warranty must be made to the dealer which originally sold the product and all warranty adjustments must be made through such dealer. Land Pride reserves the right to make changes in materials or design of the product at any time without notice.

This Warranty shall not be interpreted to render Land Pride liable for damages of any kind, direct, consequential, or contingent to property. Furthermore, Land Pride shall not be liable for damages resulting from any cause beyond its reasonable control. This Warranty does not extend to loss of crops, any expense or loss for labor, supplies, rental machinery or for any other reason.

No other warranty of any kind whatsoever, express or implied, is made with respect to this sale; and all implied warranties of merchantability and fitness for a particular purpose which exceed the obligations set forth in this written warranty are hereby disclaimed and excluded from this sale.

This Warranty is not valid unless registered with Land Pride within 30 days from the date of purchase by the end user.



Corporate Office: P.O. Box 5060
Salina, Kansas 67402-5060 USA
www.landpride.com

Free Manuals Download Website

<http://myh66.com>

<http://usermanuals.us>

<http://www.somanuals.com>

<http://www.4manuals.cc>

<http://www.manual-lib.com>

<http://www.404manual.com>

<http://www.luxmanual.com>

<http://aubethermostatmanual.com>

Golf course search by state

<http://golfingnear.com>

Email search by domain

<http://emailbydomain.com>

Auto manuals search

<http://auto.somanuals.com>

TV manuals search

<http://tv.somanuals.com>