

**Oven Gas Conversion Kit p/n 36856**  
**PS360EWB and PS360WB70**  
*Natural Gas to Propane Installation Instructions*



**WARNING**

This conversion kit is to be installed by a Middleby Marshall Authorized Service Organization in accordance with the manufacturer's instructions and all codes and requirements of the authority having jurisdiction. Failure to follow instructions could result in serious injury or property damage. The authorized service organization performing this work assumes responsibility for this conversion.

This kit consists of the following parts:

Qty.	Units	p/n	Description
1	ea.	36857	Instructions for Conversion of Natural Gas Operation to Propane Operation, PS360EWB and PS360WB70
1	ea.	31819	Orifice, Pilot Assembly - Propane, 0.025" (0.64mm)
1	ea.	31822	Orifice, Main - Propane, 0.185" (4.70mm)
1	ea.	22174-0009	Orifice, Low Flame - Propane, 0.034" (0.86mm, #62 drill) - used for converting PS360WB70 only
1	ea.	22500-0065	Label, LPG, Red
1	ea.	22500-0123	Label, Conversion - Gas



**IMPORTANT**

When converting any oven that is installed at an altitude above 5000 ft. (1524m), consult Middleby before installing this Kit.

**1. PREPARATION**

- 1.1 Turn off the electric power supply to the oven.
- 1.2 Turn off the gas supply at the service valve behind the oven.



**WARNING**

Before performing any service or conversion work, the electrical power supply AND the gas supply **MUST** be turned off.

- 1.3 Open the machinery compartment access door.

**2. PILOT ORIFICE REPLACEMENT**

- 2.1 Unscrew the brass fittings at both ends of the aluminum pilot tubing that connects the pilot orifice to the combination gas control valve. This allows the tubing to be removed. See **Figure 1**.

**Figure 1**  
**Conversion component locations**

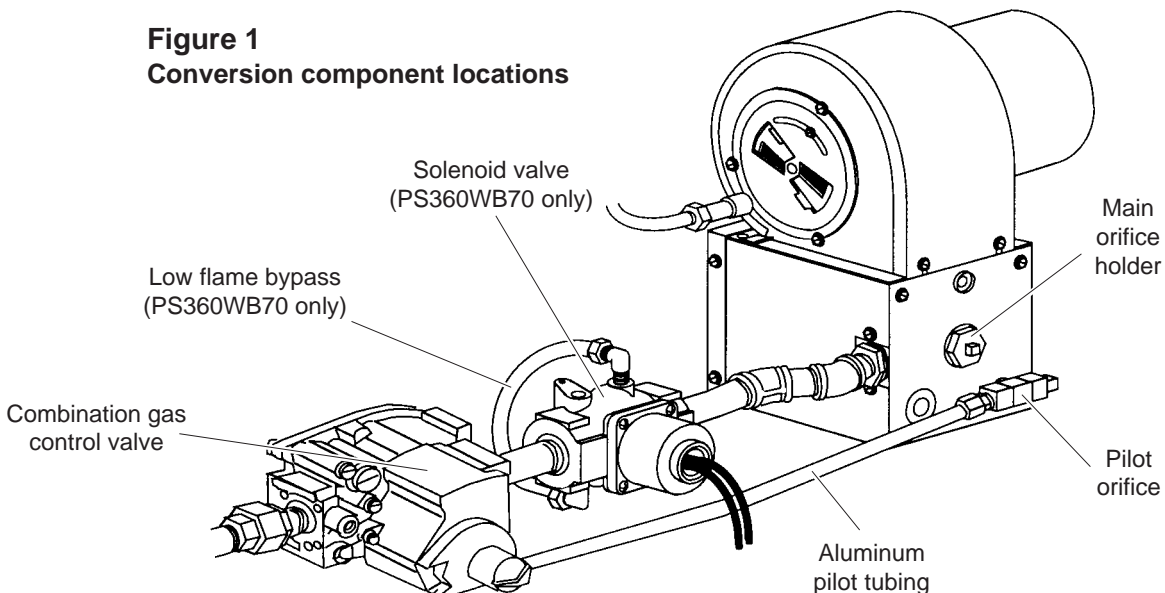

- 2.2 Remove and retain the aluminum pilot tubing from the burner assembly. The end of the tubing that enters the combination gas control valve should be removed first.
- 2.3 Remove and retain the pilot orifice by unscrewing it (counterclockwise) from the burner plenum wall.
- 2.4 Unscrew and retain the pilot tubing connector and the pilot tap plug from the ends of the pilot orifice, as shown in **Figure 2**. When these attachments have been removed, discard the pilot orifice.
- 2.5 Screw the pilot tubing connector and the pilot tap plug into place in the new propane pilot orifice (p/n 31819). Tighten them to a snug fit.
- 2.6 Screw the new propane pilot orifice into its opening in the plenum wall. Tighten it to a snug fit. Ensure that the end of the orifice holding the pilot tubing mount points towards the piping assembly.
- 2.7 Replace the aluminum pilot tubing that was removed in **Step 2.2**, above.
- 2.8 Screw in the brass fittings at both ends of the aluminum pilot tubing. Tighten them to a snug fit. **DO NOT OVERTIGHTEN THE FITTINGS.**

### 3. MAIN ORIFICE REPLACEMENT

- 3.1 Remove and retain the main orifice holder by unscrewing it (counterclockwise) from the burner plenum wall.
- 3.2 Unscrew and discard the main orifice from the inner end of the holder, as shown in **Figure 3**.
- 3.3 Screw the new propane main orifice (p/n 31822) into the orifice holder. Tighten it to a snug fit.
- 3.4 Replace the main orifice holder into its opening in the burner plenum. Tighten it to a snug fit.

### 4. LOW FLAME ORIFICE REPLACEMENT (PS360WB70 only)

- 4.1 Unscrew the brass fittings at both ends of the aluminum low flame tubing. This allows the tubing to be removed. See **Figure 4**.
- 4.2 Remove and retain the tubing from the solenoid valve.
- 4.3 Remove and discard the low flame orifice from the end of the low flame tubing.
- 4.4 Insert the new propane low flame orifice (p/n 22174-0009) into the discharge end of the low flame tubing, as shown in **Figure 4**.
- 4.5 Replace the low flame tubing into the fittings on the solenoid valve.
- 4.6 Screw in the brass fittings at both ends of the aluminum low flame tubing. Tighten them to a snug fit.

### 5. GAS LEAK TEST

- 5.1 Paint all pipe connections from the gas union to the burner plenum, and the aluminum pilot and low flame orifice tubing connections, with a solution of soap and water (2/3 soap, 1/3 water is recommended). Any bubbles that are visible indicate a gas leak.
- 5.2 If a gas leak is detected, tighten the affected joints and connections. If tightening the connections fails to stop the leak, replace the affected component and repeat the gas leak test.



#### **WARNING - FIRE / EXPLOSION HAZARD**

**Hidden gas leaks can cause a flashback in the machinery compartment. THIS CAN CAUSE SEVERE INJURY OR DEATH. Stand well clear when switching on the heating circuit.**

- 5.3 If no leaks are detected by the test, switch on the oven. Switch on the heating circuit to ignite the main burner.
- 5.4 With the burner in operation, paint all gas pipe joints with the solution of soap and water.
- 5.5 If any further gas leaks are detected, shut down the oven. Reseal and tighten the affected joints and connections. If tightening the connections fails to stop the leak, replace the affected component(s) and repeat the gas leak test.

**Figure 2**  
**Pilot orifice assembly**

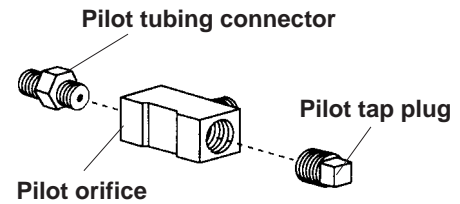

**Figure 3**  
**Main orifice and holder**

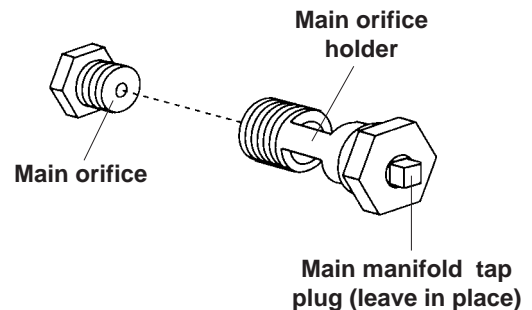

**Figure 4**  
**Low flame orifice replacement**

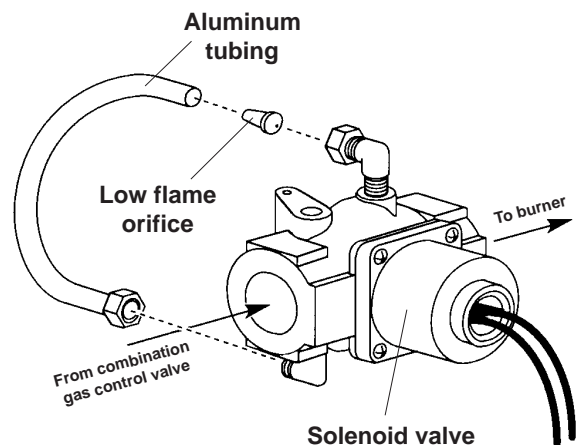

## 6. INLET PRESSURE CHECK

- 6.1 Check the gas control inlet pressure at the inlet pressure tap. See **Figure 6**. An inlet pressure of 6-14" (14.9-34.9mbar) is recommended for propane operation.
- 6.2 If the inlet pressure is:
- HIGHER THAN 14" W. C. (34.9mbar) - This pressure may damage the combination gas control valve. Decrease the supplied gas pressure.
  - LOWER THAN 3" W. C. (7.46mbar) - It may be necessary to increase the supplied gas pressure.
- If it is necessary to adjust the gas line pressure, have the customer contact the gas utility supplier.

## 7. PILOT PRESSURE ADJUSTMENT

- 7.1 Ensure that the air supply is properly adjusted for propane operation.
- Units with a burner blower air shutter (see **Figure 5**) should have the shutter opening (at its outside edge) set to 5/16" (7.94mm). A drill bit can be used to check the adjustment of this opening.
  - Units without the air shutter (see **Figure 5**) should have the burner air supply adjustment screw turned 11-17 full revolutions clockwise from the fully closed (counterclockwise) position. The screw is located on the front wall of the burner plenum, and is surrounded by a "MORE AIR" label.

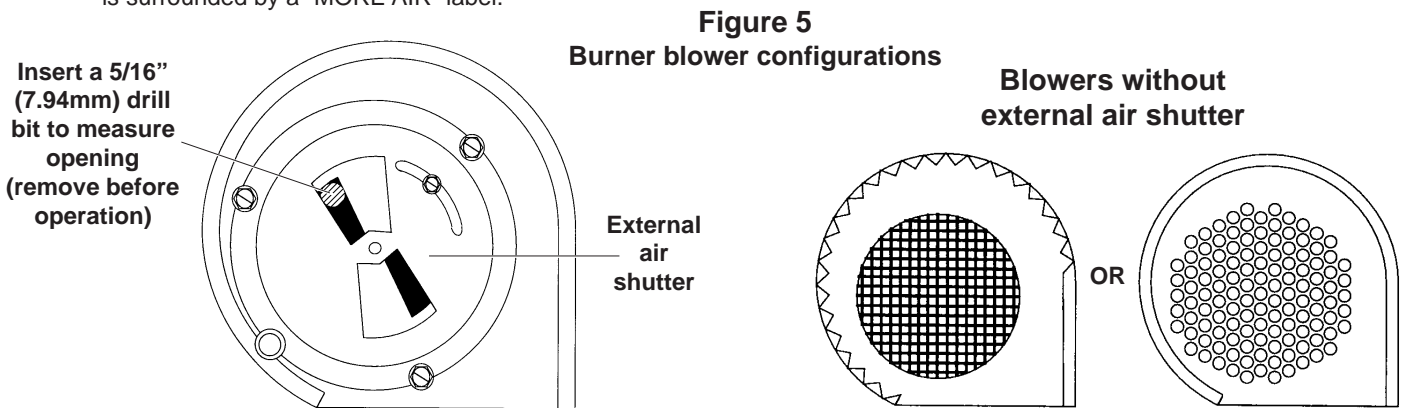

- 7.2 Before proceeding:
- For a PS360EWB oven, the set point should be reduced below the room temperature.
  - For a PS360WB70 oven, set the oven to low flame.

- 7.3 Measure the pilot pressure at the pilot pressure tap, as shown in **Figure 6**. The gas pressure should be 5-6" W. C. (12.5-14.9mbar) for proper operation.

- 7.4 If necessary, adjust the pilot pressure as follows:
- Remove the pilot adjustment cap screw.
  - Using a screwdriver, turn the inner adjustment screw counterclockwise to increase, or clockwise to decrease, the pilot gas pressure.
  - Replace the cap screw and tighten it firmly.

- 7.5 Measure the current across the pilot flame sensor. The current must measure **at least 2.0  $\mu$ A**. If the current reading is too low, recheck the pilot pressure as per **Step 7.3**. If the pressure reading is correct, consult the factory; otherwise, repeat **Steps 7.4** and **7.5**.

## 8. MAIN MANIFOLD PRESSURE ADJUSTMENT

- 8.1 With the oven set to high flame, measure the regulated gas pressure to the burner. The outlet pressure should be checked at the main orifice pressure tap. See **Figure 6**. The gas pressure should be 3" W. C. (7.46mbar) for proper operation.

- 8.2 If necessary, adjust the pressure regulator as follows:
- Remove the pressure regulator cap screw.
  - Using a screwdriver, turn the inner adjustment screw clockwise to increase, or counterclockwise to decrease, the main burner gas pressure.
  - Replace the cap screw and tighten it firmly.

- 8.3 Record the final measured regulated gas pressure on the silver conversion information label (included in the kit).

**Figure 6**  
Gas pressure measurement/adjustment locations

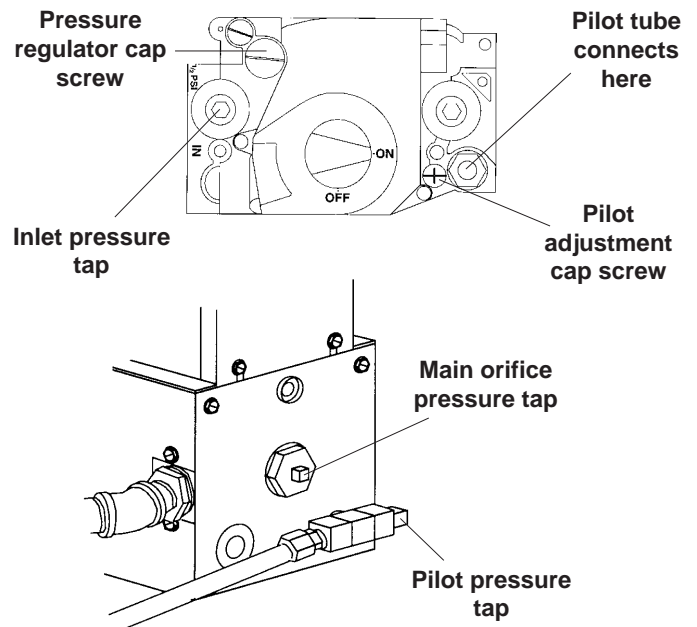

## 9. CONVERSION LABELING

- 9.1 Remove and discard the round, green "NAT." label from the front face of the burner plenum.
- 9.2 Apply the round, red "LPG." label (p/n 22500-0065) to the front face of the burner housing as shown in **Figure 7**.
- 9.3 Close the machinery compartment access door.
- 9.4 Record the information requested on the silver conversion information label. **Figure 8** shows a representation of this label.
- 9.5 Apply the conversion information label to the front of the machinery compartment access door, next to the control panel. See **Figure 9**.

**Figure 7**  
Red "LPG." label placement  
(on burner housing)

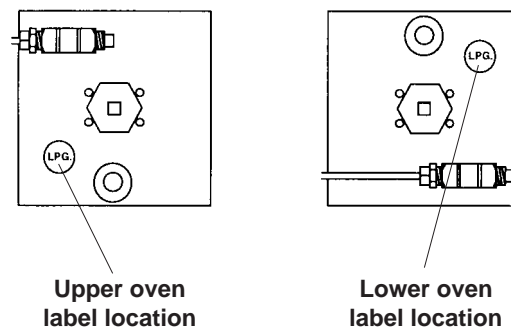

**Figure 8**  
Conversion information label

Signature of technician performing conversion \_\_\_\_\_ Date of conversion \_\_\_\_\_

THIS APPLIANCE HAS BEEN CONVERTED ON \_\_\_\_\_ TO PROPANE GAS WITH KIT NO. 36856 BY \_\_\_\_\_, WHO ACCEPTS THE RESPONSIBILITY FOR THE CORRECTNESS OF THIS CONVERSION.

MODEL NO. [ ] MAIN BURNER ORIFICE SIZE [185"/4.70mm] MANIFOLD PRESSURE [ ]

INPUT RATING [175,000 BTU] MAXIMUM INLET PRESSURES [14" W.C./34.9mbar]

Stated on the oven's data plate

Measured value recorded in Step 8.3

**Figure 9**  
Conversion information label placement

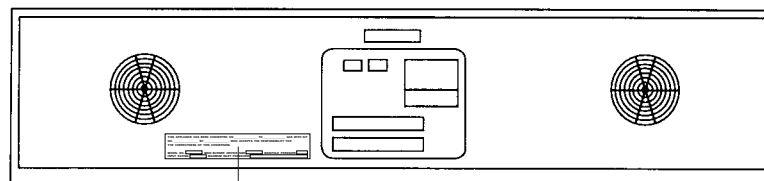

PS360EWB placement

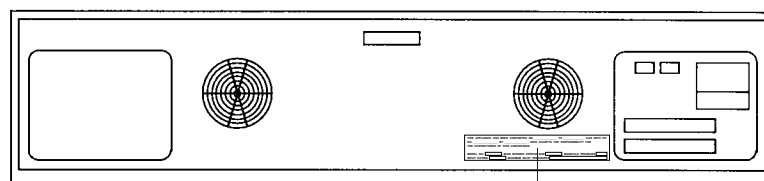

PS360WB70 placement

## Free Manuals Download Website

<http://myh66.com>

<http://usermanuals.us>

<http://www.somanuals.com>

<http://www.4manuals.cc>

<http://www.manual-lib.com>

<http://www.404manual.com>

<http://www.luxmanual.com>

<http://aubethermostatmanual.com>

Golf course search by state

<http://golfingnear.com>

Email search by domain

<http://emailbydomain.com>

Auto manuals search

<http://auto.somanuals.com>

TV manuals search

<http://tv.somanuals.com>