

# ALTO®

CLARKE  
TECHNOLOGY

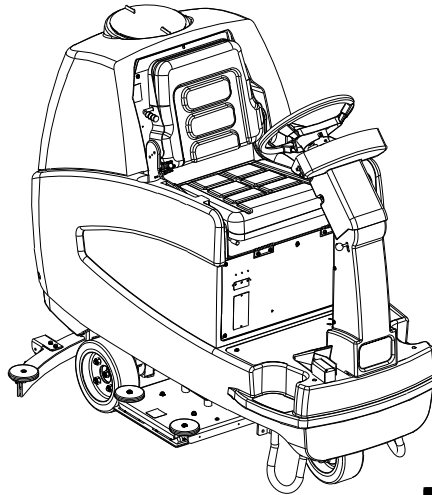

## Operator's Manual

**Manual Steering Models**  
**SCRUBTEC R 571**  
**SCRUBTEC R 571 C**  
**SCRUBTEC R 586**  
**SCRUBTEC *BOOST* R**

U.S. Patent No. 6,105,192; No. RE39,581; No. 6,557,207; No. 7,185,397; and Patents Pending

### READ THIS BOOK

**⚠ CAUTION:** Read the Operator's Manual before using the appliance.

This book has important information for the use and safe operation of this machine. Failure to read this book prior to operating or attempting any service or maintenance procedure to your ALTO machine could result in injury to you or to other personnel; damage to the machine or to other property could occur as well. You must have training in the operation of this machine before using it. If operator(s) cannot read this manual, have it explained fully before attempting to operate this machine.

All directions given in this book are as seen from the operator's position at the rear of the machine.

For new books write to: ALTO, 2100 Highway 265, Springdale, Arkansas 72764.

# Table of Contents

Operator Safety Instructions .....	3
Introduction & Machine Specifications .....	5
Symbols Used on Scrubtec .....	6
Display Screens for Scrubtec .....	7
Machine Control Panel .....	8
Machine Controls and Features .....	9
How to Prepare the Machine for Operation .....	10
How to Handle the Packed Machine .....	10
How to Unpack the Machine .....	10
How to Install the Batteries .....	10
Battery Maintenance .....	11
How to Charge the Batteries .....	12
Recharging the Batteries .....	12
Level Indicators for the Charge on the Batteries .....	13
How to Install the Squeegee .....	13
How to Adjust the Squeegee .....	13
How to Change or Rotate Brushes on Cylindrical Brush Head .....	14
How to Install and Remove the Brush or Pad on the Boost Head .....	15
How to Operate the Machine .....	16
How to Return One Touch to Factory Default Settings .....	16
How to Move Machine .....	16
Seat Adjustment .....	16
How to Read the Battery Meter .....	17
How to Change Display Screens on the LCD Module .....	17
How to Read the Solution Empty Indicator .....	17
How to Read the Recovery Full Indicator .....	17
How to Operate the Squeegee and the Vacuum Motor .....	18
How to Operate the Solution Flow .....	18
How to Operate Brush Pressure .....	18
How to Operate the Forward / Reverse Switch .....	18
How to Fill the Solution Tank .....	19
Operating the Machine .....	19
Do These Procedures When You Begin Your Work Period .....	20
How to Clean a Floor .....	21
How to Clean a Very Dirty Floor .....	22
Do These Procedures When You End Your Work Period .....	22
Maintenance .....	24
Maintenance to Be Done Every Week .....	24
Battery Inspection and Cleaning .....	24
Cleaning the Recovery Tank and Filter .....	24
Cleaning the Solution Tank and Filter .....	25
Manually Draining the Solution Tank .....	25
Vac Assisted Solution Tank Draining .....	25
Squeegee Maintenance .....	25
Front Squeegee Blade Replacement .....	25
Rear Squeegee Blade Replacement .....	26
Squeegee Maintenance .....	26
Cleaning the Vac Hose .....	26
How to Correct Problems in the Machine .....	27
Common Error Codes .....	28
Accessories and Options .....	29

## SECTION II Parts and Service Manual

Final Assembly Drawing .....	32
Parts List .....	33
Main Frame Assembly Drawing (Rotary) .....	34
Parts List .....	35
Main Frame Assembly Drawing (Cylindrical) .....	36
Parts List .....	37
Main Frame Assembly Drawing (BOOST) .....	38
Parts List .....	39
Optional Side Squeegee Lift (28 & 34 Rotary Models) .....	40
Parts List .....	41
Front Wheel Assembly Drawing and Parts List .....	42
Squeegee Lift Assembly Drawing and Parts List .....	43
Recovery Tank Assembly Drawing .....	44
Parts List .....	45
Solution Tank Assembly Drawing (View 1) .....	46
Parts List (View 1) .....	47
Solution Tank Assembly Drawing (View 2) .....	48
Parts List (View 2) .....	49
Steering Column Assembly Drawing .....	50
Parts List .....	51
28" Rotary Brush Head Assembly Drawing and Parts List .....	52
34" Rotary Brush Head Assembly Drawing and Parts List .....	53
28" Cylindrical Head Assembly Drawing .....	54
Parts List .....	55
32" Boost Head Assembly Drawing .....	56
Parts List .....	57
Squeegee Assembly Drawing .....	58
Parts List .....	59
Front Squeegee Assembly Drawing and Parts List .....	60
Front Squeegee Arm Assembly Drawing and Parts List .....	61
Electrical Panel Assembly Drawing and Parts List .....	62
Electrical Connection Diagram .....	63
Electrical Schematic .....	67

# OPERATOR SAFETY INSTRUCTIONS

 **DANGER:** Failure to read and observe all **DANGER** statements could result in severe bodily injury or death. Read and observe all **DANGER** statements found in your Owner's Manual and on your machine.

 **WARNING:** Failure to read and observe all **WARNING** statements could result in injury to you or to other personnel; property damage could occur as well. Read and observe all **WARNING** statements found in your Owner's Manual and on your machine.

 **CAUTION:** Failure to read and observe all **CAUTION** statements could result in damage to the machine or to other property. Read and observe all **CAUTION** statements found in our Owner's Manual and on your machine.

 **DANGER:** Failure to read the Operator's Manual prior to operating or attempting any service or maintenance procedure to your ALTO machine could result in injury to you or to other personnel; damage to the machine or to other property could occur as well. You must have training in the operation of this machine before using it. If your operator(s) cannot read English, have this manual explained fully before attempting to operate this machine.

 **DANGER:** Operating a machine that is not completely or fully assembled could result in injury or property damage. Do not operate this machine unless it is completely assembled. Inspect the machine carefully before operation. Operate only when lids, doors and access panels are securely closed.

 **DANGER:** Machines can cause an explosion when operated near flammable materials and vapors. Do not use this machine with or near fuels, grain dust, solvents, thinners, or other flammable materials. This machine is not suitable for picking up hazardous dust or flammable materials. Use only commercially available floor cleaning waxes intended for machine operation. **DO NOT** put gasoline, combustible or flammable materials in the solution or recovery tank.

 **DANGER:** Lead acid batteries generate gases which can cause an explosion. Keep sparks and flames away from batteries. Do not smoke around the machine. Charge the batteries only in an area with good ventilation.

 **DANGER:** Working with batteries can be dangerous! Always wear eye protection and protective clothing when working near batteries. Remove all jewelry. Do not put tools or other metal objects across the battery terminals, or the tops of the batteries.

 **DANGER:** Using the charger with a damaged power cord could result in an electrocution. Do not use the charger if the power cord is damaged.









 **WARNING:** Do not turn the machine on a ramp. Do not use on surfaces having a gradient exceeding that marked on the appliance.

 **WARNING:** Machines can topple over and cause injury or damage if guided over the edges of stairs or loading docks. Stop and leave this machine only on a level surface. When you stop the machine, put all switches into their "OFF" position. Turn the key switch "OFF" and remove the key.

 **WARNING:** Skidding may occur when traveling at high speeds and attempting sharp turns, especially on wet surfaces.

 **WARNING:** Do not move machine with forklift. Damage could occur to machine.

 **WARNING:** Maintenance and repairs performed by unauthorized personnel could result in damage or injury. Maintenance and repairs must be performed by authorized ALTO personnel only.

-  **WARNING:** Any alterations or modifications of this machine could result in damage to the machine or injury to the operator or other bystanders. Alterations or modifications not authorized by the manufacturer voids any and all warranties and liabilities.
-  **WARNING:** Electrical components of this machine can "short-out" if exposed to water or moisture. Keep the electrical components of the machine dry. Wipe the machine down after each use. This appliance is for dry use only and is not to be used or stored outdoors in wet conditions. For storage, keep the machine in a building.
-  **WARNING:** Operating a machine without observing all labels and instructional information could result in injury or damage. Read all machine labels before attempting to operate. Make sure all of the labels and instructional information are attached or fastened to the machine. Do not cover them for any reason. If labels or decals are missing or become damaged, get replacement labels and decals from your ALTO distributor immediately.
-  **WARNING:** Wet floor surfaces can be slippery. Water solutions or cleaning materials used with this type of machine can leave wet areas on the floor surface. These areas can cause a dangerous condition for the operator or other persons. Always put "Caution" signs around/near the area you are cleaning.
-  **WARNING:** Improper discharge of waste water may damage the environment and be illegal. The United States Environmental Protection Agency has established certain regulations regarding discharge of waste water. City, state and national regulations regarding this discharge may also be in effect in your area. Understand and follow the regulations in your area. Be aware of the environment hazards of chemicals that you dispose.
-  **WARNING:** Only use the brushes provided with the appliance or those specified in the Operator's Manual. The use of other brushes may impair safety.
-  **CAUTION:** Use of this machine to move other objects or to climb on could result in injury or damage. Do not use this machine as a step or furniture.
-  **CAUTION:** Your machine warranty will be voided if anything other than genuine ALTO parts are used on your machine. Always use ALTO parts for replacement.
-  **CAUTION:** This machine contains lead acid batteries. The batteries must be disposed of in an environmentally acceptable manner.

 **WARNING: GENERAL SAFETY RULES**

The rules below have to be followed carefully in order to avoid injury to the operator and damage to the machine:

- During the operation of this machine, pay attention to other people around you, especially children.
- Use care when reversing machine in confined areas.
- Do not mix different kinds of detergents. Avoid harmful odors.
- Do not place any liquid containers on to the machine.
- The recommended operating temperature should be between 32° F and 104° F.
- The humidity for operating this machine should be between 30 and 95%.
- Do not use acid solutions that could damage the machine.
- In order to prevent floor damage, do not leave brushes running when machine is standing still.
- In case of fire, use a powder extinguisher. Do not use water.
- Do not strike shelving or scaffoldings, where there is danger of falling objects.
- Adapt the utilization speed to the adhesion conditions.
- Do not exceed the declared hill climbing capacity, otherwise the machine could become unstable.
- For any maintenance operation take off the power supply from the machine.
- Do not disassemble any parts which require the use of a tool to be removed.
- Do not wash the machine with direct water jets or with high water pressure nor with corrosive material.
- After every 200 working hours have machine checked by an authorized service person.

**English** **Correct Disposal of This Product (Waste Electrical & Electronic Equipment)**  
**(Applicable in the European Union and other European countries with separate collection systems)**



This marking shown on the product or its literature, indicates that it should not be disposed with other household wastes at the end of its working life. To prevent possible harm to the environment or human health from uncontrolled waste disposal, please separate this from other types of wastes and recycle it responsibly to promote the sustainable reuse of material resources. Household users should contact either the retailer where they purchased this product, or their local government office, for details of where and how they can take this item for environmentally safe recycling. Business users should contact their supplier and check the terms and conditions of the purchase contract. This product should not be mixed with other commercial wastes for disposal.

**Introduction**

**Introduction & Machine Specifications**

This is a floor cleaning machine which, using the mechanic abrasive action of brushes or pads and the chemical action of a water-detergent solution, is able to clean any type of floor. During its forward movement, it picks up the removed dirt and the detergent solution which has not been absorbed by the floor.

Model	SCRUBTEC R 571	SCRUBTEC R 586	SCRUBTEC R 571 C	SCRUBTEC BOOST® R
Part Number				
Cleaning Swath	28" (71.1 cm)	34" (86.4 cm)	28" (71.1 cm)	32" (81.3 cm)
Power Supply	36 volt system using (6) 6 volt 250, 330, or 370 AH deep cycle batteries			
Battery Charger	On-Board fully automatic smart charger, 115V 60 Hz or 230V 50 Hz			
Brush Motors	(1) 2 hp (1.5 kW) driving two right angle gearboxes	(1) 2.5 hp (1.9 kW) driving two right angle gearboxes	(2) .75 hp (.56 kW)	(1) .75 hp (.56 kW)
Brush Size / Speed	(2) 14" (36 cm) 300 RPM	(2) 17" (43 cm) 300 RPM	(2) 6 x 28" (15.2 x 71.1 cm) 300 RPM	(1) 14 x 32" (35.6 x 81.3 cm) 2250 RPM
Brush Pressure	12 -225 lbs. (57-102 kg)		90-130 lbs. (41-59 kg)	115-155 lbs. (52-70 kg)
Traverse Speed (max)	4.1 mph (6.6 kph)			
Traverse	1.5 hp (1.1 kW) transaxle powering of two 10" (25.4 cm) diameter rear wheels			
Max. Cleaning Grade	6 degree			
Vacuum Motor	1 hp (.75 kW) 3 stage tangential discharge			
Noise Level	70 dBA			
Solution Tank	30 gallon (113 liter)			
Recovery Tank	30 gallon (113 liter)			
Length	65" (165 cm)			
Width	33" (84 cm)	35.5" (90 cm)	30" (130 cm)	33" (84 cm)
Height	56" (142cm)			
Machine Weight w/330 AH batteries & full of solution	1478 lbs. (670 kg)	1498 lbs. (679 kg)	1498 lbs. (679 kg)	1488 lbs. (675 kg)
Warranty	8 years Polydur™ tanks, 3 years parts, 1 year labor, 18 months pro-rated batteries			

**Symbols Used On Scrubtec R**

Brush Up/Down

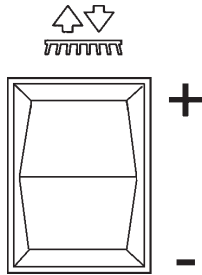

Forward / Reverse

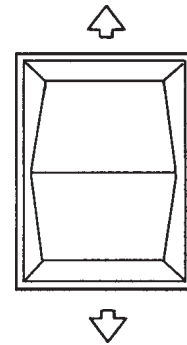

Squeegee Up/Down

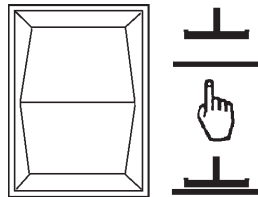

Horn



Solution Flow Switch

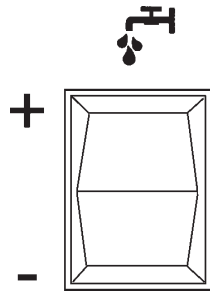

On/Off Switch

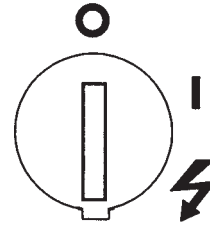

Battery Meter



Recovery / Solution LED

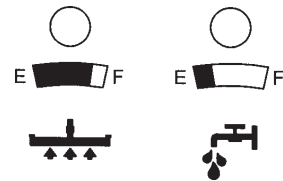

LCD Display Button

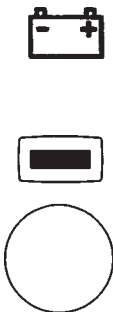

WARNING

**READ OPERATOR'S MANUAL BEFORE OPERATING THIS MACHINE**

**RISK OF FIRE**

- Use only commercially available floor cleaners and waxes intended for machine operation.
- Do not use flammable materials.

**RISK OF INJURY OR DAMAGE TO MACHINE**

- Do not turn, stop or leave machine on a ramp or dock.

One Touch Button

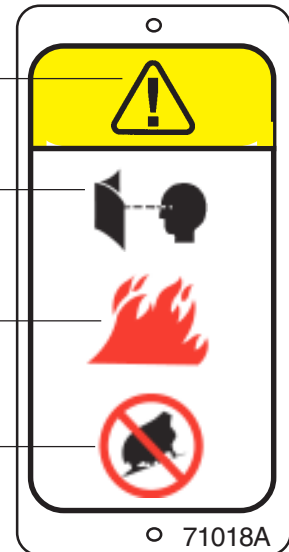

# Display Screens For Scrubtec R

Traverse speed indicator  
 1 = low 0-3 KPH  
 2 = med 0-5 KPH  
 3 = high 0-6.4 KPH

Position arrow indicating current position of squeegee (up or down)

Indicators are on, showing current settings.

Water "droplets" off when solution is off and they are flashing when solution is on.

"Battery" blinks when low voltage occurs.

Arrows indicating vacuum status. They are flashing when vac is on and off when vac is off.

Screens Available to Operator

SCREEN 1

SCREEN 2

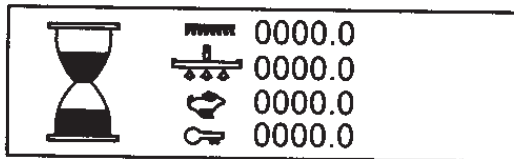
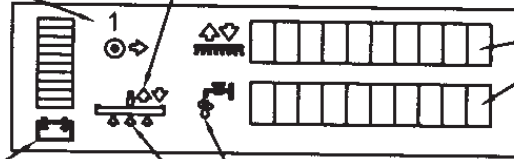

Example

SCREEN 3 (Diagnostic)



The Diagnostic only. It will not show unless a fault with the machine occurs. When the fault happens the icon and error code will be displayed.

## Machine Control Panel

### **On/Off Key Switch (See figure 1, Item D)**

The key switch turns "ON" the power to the control panel. "O" is the "OFF" and "I" is the "ON".

### **Brush Up/Down Switch (See figure 1, Item A)**

To lower brush head, push the brush switch in the down (+) position. To lower the brush head to maximum brush pressure, continue to hold the switch in the down (+) position until the travel stops. The brush motors will start and solution will flow (provided the solution is turned "ON") when the machine begins to traverse. To raise the brush head, push the brush switch in the up (-) position until the brush head travel stops or desired position is reached.

### **Squeegee Up/Down Switch (See figure 1, Item B)**

The squeegee switch is used to raise and lower the squeegee and to turn on and off the vacuum motor. The vacuum motor is turned on when the switch is placed in the middle or lower position. **NOTE: When the squeegee switch is placed in the lower position, the vacuum motor will turn on.**

To raise the squeegee, place the switch in either the middle or up position. The middle position is used for one touch control. The vacuum motor will stop, after a short delay, when the switch is placed in the up position.

### **Hour Meter (See figure 1, Item E)**

The hour meter is located on the front display. You must toggle screens using LCD display button. The hour meter indicates the number of hours the machine has operated. It displays brush motor, vacuum motor, traverse motor and total key on times.

### **Battery Meter (See figure 1, Item F)**

The battery meter indicates the relative charge on the battery pack. The battery meter is located on screen 1 on the front display. See page 7.

### **Solution Flow Control (See figure 1, Item C)**

The solution flow switch regulates the flow of chemical solution to the floor. To increase the flow, toggle (+). To decrease the flow, toggle (-). To shut off the solution, toggle - until no indicators are visible on display. **NOTE: DO NOT run dry!**

**NOTE: No solution will flow when the machine does not traverse.**

### **Circuit Breakers**

The circuit breaker reset buttons are located on the back side of the front cover below front display. The breakers are as follows:

- Item A - Main (5 amp)
- Item B - Key Switch (5 amp)

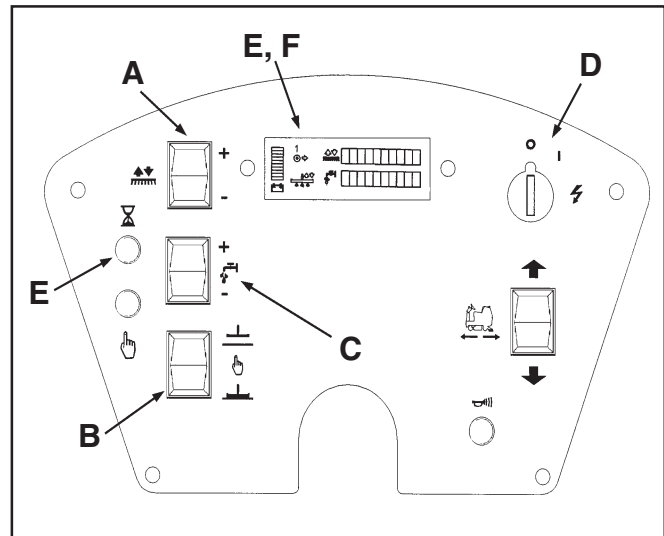

Figure 1



## Machine Controls and Features

### **Recovery Tank Float**

The Scrubtec R is equipped with a float that shuts the vacuum off when the recovery tank is full. The squeegee will no longer pick up water. If this should happen, raise the squeegee and empty the recovery tank.

### **The Traverse**

The Scrubtec R is equipped with an electronically controlled traverse system with variable speeds in forward and reverse.

1. To traverse the machine, the power to the machine must be turned on with the key switch and the operator must be properly seated.
2. The traverse speed can be adjusted by varying the pressure on the foot pedal.

**NOTE: During reverse motion, the squeegee raises and the solution flow stops automatically. Reverse also reduces maximum traverse speed.**

### **Brakes**

The machine is equipped with an electronic braking system. The electronic braking is activated automatically. NOTE: During training, you should allow machine to come to a full stop until you become familiar with stopping distances required.

### **Parking Brake**

The parking brake is activated automatically when the machine comes to a stop. It disengages automatically when you begin to traverse. The transaxle is equipped with a manual brake release. NOTE: Machine will not function when manual brake release is engaged. See figure 2.

### **Reverse Alarm**

The reverse alarm will sound intermittently and automatically when the machine is in reverse.



Figure 2

## How To Prepare the Machine For Operation

### How To Handle the Packed Machine

The machine is packed in a specific package provided on a pallet so that it can be moved with a forklift.

**WARNING:** The packages cannot be placed on top of each other.

### How to Unpack the Machine

1. Remove the outer package.
2. The machine is fixed on the pallet with banding straps and wooden blocks to prevent movement during shipment. Remove the bands and blocks.
3. Remove tie down brackets.
4. Lower the ramp. The machine can be lowered off the pallet if the operator is thoroughly familiar with its operation. Avoid violent blows to the base unit.
5. Keep the pallet for future transport necessities.

### How to Install the Batteries

**WARNING:** The batteries are heavy. Lifting batteries without help could result in an injury. Get help to lift the batteries.

**WARNING:** Working with batteries can be dangerous. Always wear eye protection and protective clothing when working near batteries. **NO SMOKING!**

**WARNING:** Hydrogen gas is formed during the charging operation and is explosive. Only charge batteries in a well ventilated area with the seat base lifted.

The batteries are fitted in the battery compartment under the seat and recovery tank (figure 4). The machine uses six - 6 volt batteries. They must be handled by using appropriate lifting equipment suitable for the weight and for the coupler system. For maintenance and daily recharge of the batteries, it is necessary to follow all instructions given by the manufacturer.

For Battery Installation follow these steps (See figure 4):

1. Make sure that the key switch is in the "OFF" position.
2. Lift and rotate the base support of the seat forward.
3. Lean the seat on it's restraint cable.
4. Lift the front of the recovery tank and rotate it towards the rear until it rests on it's restraint cable.
5. Put the batteries into position and connect the battery cables as shown in figure 3.
6. Rotate the recovery tank and then carefully rotate it forward to the normal operating position.
7. Lower the base support of the seat.  
**NOTE:** Charge the batteries before using.

### BATTERY CONNECTIONS

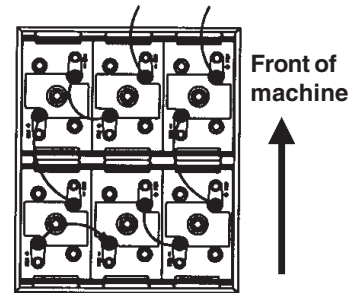

370 AH, 6 Volt  
(Battery No. 40704A Wet)  
(Battery No. 40602A Dry)

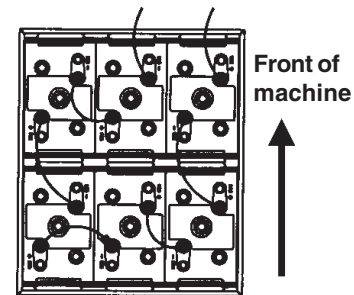

330 AH, 6 Volt  
(Battery No. 891384 Wet)  
(Battery No. 891385 Dry)

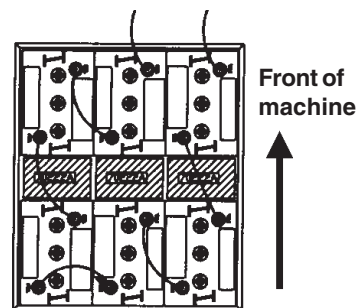

250 AH, 6 Volt  
(Battery No. 881317 Wet)  
(Battery No. 881318 Dry)  
Three (3) 70222A Spacers

Figure 3

## How To Prepare the Machine For Operation

### Battery Maintenance

The electrical power to operate the machine comes from the storage batteries. Storage batteries need preventative maintenance.

**⚠ WARNING:** Working with batteries can be dangerous. Always wear eye protection and protective clothing when working near batteries. **NO SMOKING!**

To maintain the batteries in good condition, follow these instructions:

1. Keep the electrolyte at the correct level. The correct level is between 1/4" (1/2 cm) below the bottom of the tube in each cell and above the tops of the plates. Check the level of the electrolyte each time you charge the batteries (see figure 4).

**NOTE:** Check the level of electrolyte prior to charging the batteries. Be sure the plates in each cell are covered with electrolyte before charging. Do not top off the cells prior to charging the battery. Electrolyte expands during charging. As a result, the electrolyte could overflow from the cells. Always top off the cells with distilled water after charging.

**⚠ CAUTION:** Irreversible damage will occur to the batteries if electrolyte does not cover the plates. Keep the electrolyte at the correct level.

**⚠ CAUTION:** Machine damage and discharge across the tops of the batteries can occur if the batteries are over filled. Do not fill the batteries up to the bottom of the tube in each cell. Wipe any acid from the machine or the tops of the batteries. Never add acid to a battery after installation.

**⚠ CAUTION:** Batteries must be refilled with distilled water only. Do not use tap water as it may contain contaminants that will damage batteries.

2. Keep the tops of the batteries clean and dry. Keep the terminals and connectors clean. To clean the top of the batteries, use a damp cloth with a weak solution of ammonia or bicarbonate of soda solution. To clean the terminals and connectors, use a terminal and connector cleaning tool. Do not allow ammonia or bicarbonate of soda to get into the batteries.
3. Keep the batteries charged.

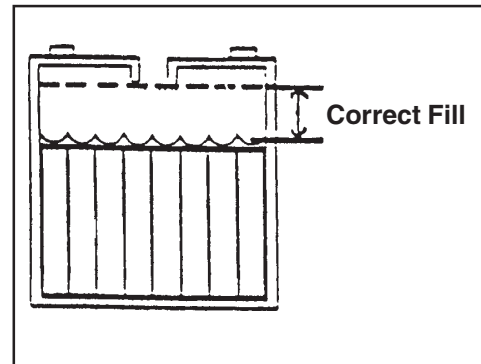

Figure 4

## How To Prepare the Machine For Operation

### How to Charge the Batteries

- ⚠ WARNING:** Charging the batteries in an area without adequate ventilation could result in an explosion. To prevent an explosion, charge the batteries only in an area with good ventilation.
- ⚠ WARNING:** Lead acid batteries generate gases which could explode. Keep sparks and flames away from batteries. **NO SMOKING!**
- ⚠ CAUTION:** See Charger Owner's Manual. All onboard battery chargers are programmed for a specific type battery. The charger may need reprogramming to properly charge replacement batteries different than the originally equipped Clarke battery.

**NOTE:** Only replace batteries with the identical Clarke battery pack as originally equipped. The correct Clarke battery part number can be found on the Clarke battery label affixed to the top of each battery.

If the replacement battery is a different Clarke battery, please contact Clarke Technical Service, 1-800-356-7274, for instructions.

If the replacement battery is not a Clarke battery, please contact the charger manufacturer for instructions.

To charge the batteries, follow this procedure:

1. Make sure the key switch is in the "OFF" position.
2. Raise the seat base support.
3. Connect the battery charger AC cord to a properly grounded wall receptacle matching plug configuration (50/60 Hz).
4. Observe indicator light to ensure the charging process has started (see figure 5, A - Red, B - Yellow, C - Green ). For color indications see figure 6.

### Recharging the Batteries

The Scrubtec R comes with an on board charger.

1. Plug into any wall socket and charging is automatic.
2. Observe indicator light to ensure the charging process has started (see figure 5, A - Red, B - Yellow, C - Green ). For color indications see figure 6.

**NOTE:** Make sure you plug into a circuit that is not loaded by other equipment. Wall breakers may be tripped and no charge will occur.

- ⚠ WARNING:** Never charge a GEL battery with an unsuitable battery charger. Carefully follow the instructions given by the manufacturer of the batteries and battery charger.

**NOTE:** To prevent permanent damage to the batteries, avoid their complete discharge. Never leave the batteries completely discharged, even if the machine is not being used. When recharging the batteries, keep the base support of the seat lifted. After every 20 recharging operations, check the level of the electrolyte and if necessary top off with distilled water.



(Shown with Optional Chemical Mixing System)  
Figure 5

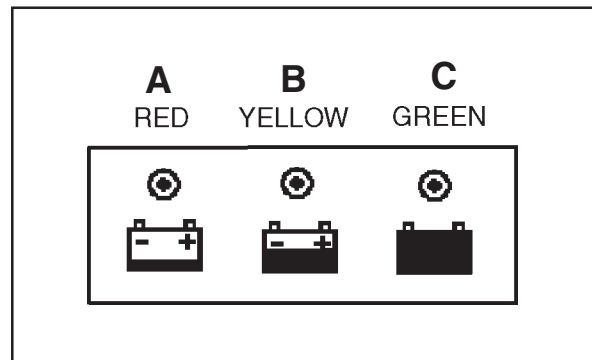

Figure 6

## How To Prepare the Machine For Operation

### Level Indicators for the Charge of the Batteries

The battery meter ( see figure 7) on the control panel has a digital read out with 10 fixed positions (A) and also a blinking indicator (B). The bars that appear on the display show the approximate charge level with icon (blinking) discharged battery.

**NOTE:** A few seconds after the voltage reads 32V it will start blinking. The brush motors will then automatically switch off.

### How To Install the Squeegee

To install the squeegee onto the machine, follow this procedure:

1. The squeegee assembly has a break away feature that is also used for mounting the squeegee. Loosen the knobs on the squeegee (figure 8). Slide the stud into the slotted hole in the support frame on the machine.
2. Attach the vacuum hose cuff to the squeegee hose fitting (see figure 9).
3. Tighten knobs. **NOTE: Do not overtighten or break away feature is lost and damage may occur.**

**NOTE:** To prevent damage to the squeegee or machine, the squeegee was designed to break away from the machine. If the squeegee is impacted and it breaks away from the machine, simply reinstall it by following step 1-3.

### How to Adjust the Squeegee

During operation, the rear squeegee blade should have a constant 3/16" minimum flare along the entire squeegee blade (see figure 10).

1. The squeegee body can be tilted to adjust the squeegee blade flare in the middle to match the flare on the ends. To adjust the tilt, loosen the adjusting bolt located on the left and right side of the squeegee (see figure 9).
2. Press down on the squeegee until both sets of guide wheels contact floor.
3. After making adjustments, retighten the screw(s).

**NOTE:** It is important that the right and left wheels are contacting the floor in order for the squeegee to work.

**NOTE:** As the rear squeegee blade wears, it can be rotated and/or flipped to obtain four good edges before having to change blades.

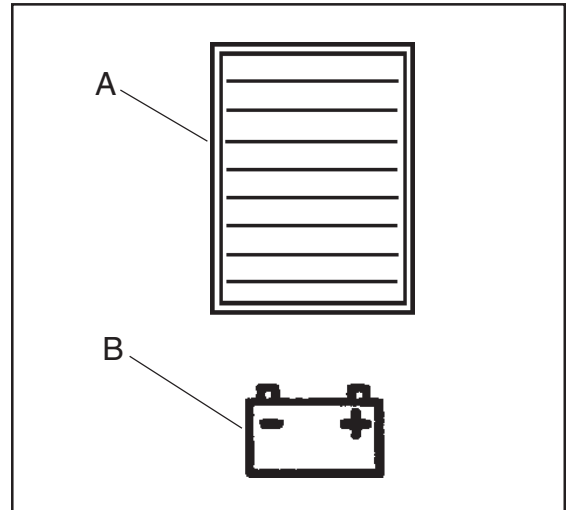

Figure 7

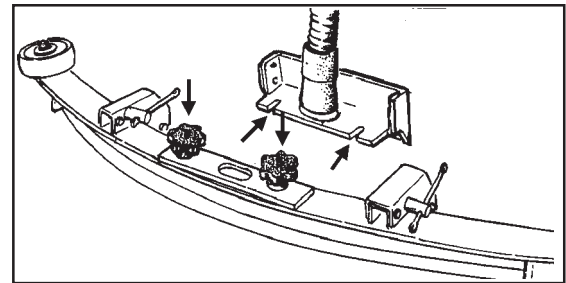

Figure 8

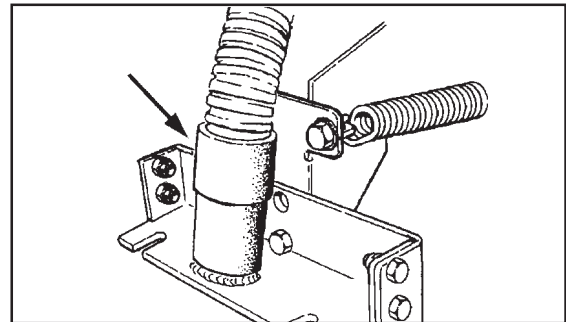

Figure 9

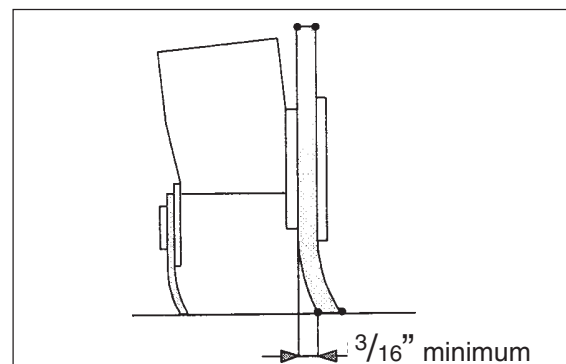

Figure 10

## How To Prepare the Machine For Operation

### How To Change or Rotate Brushes on Cylindrical Brush Head

To install or rotate brushes on the cylindrical brush head:

1. Raise the brush deck and turn the key switch "OFF".
2. Raise the brush skirt and pull out to remove. See figure 11.
3. Remove thumb screw from brush door. See figure 12.
4. Lower door approximately 12 mm and slide door and hub assembly from brush. See figure 13.
5. Slide brush off hub at opposite end. See figure 14.
6. Rotate brush or replace.
7. Slide brush on drive hub and insert door and hub assembly into brush core.
8. Raise door and install thumb screw.
9. Place side skirt on retainer pins and lower in place.
10. Brushes should be rotated after every 20 hours of use.



Figure 11



Figure 12



Figure 13



Figure 14

## How To Prepare the Machine For Operation

### How To Install The Brush Or Pad on the BOOST machine

To install the brush or pad on the BOOST machine, follow this procedure:

1. Turn the key switch "ON".
2. Put the brush switch in the "UP" position.
3. Turn the key switch "OFF".
4. Go to the side of the machine.
5. Press on a brush or pad under the flex plates. See figure 15.

NOTE: When using a black pad, position pad on head. Lower head and operate momentarily to affix pad to pad driver (if you have difficulty, position pad on floor and lower head then operate.)

### How To Remove The Brush Or Pad on the BOOST machine

To remove the brush or pad from the machine, follow this procedure:

1. Turn the key switch "ON".
2. Put the brush switch in the "UP" position.
3. Turn the key switch "OFF".
4. Go to the side of the machine.
5. Pull downward on the brush or pad until it releases from the flex plates. See figure 16.



Figure 15

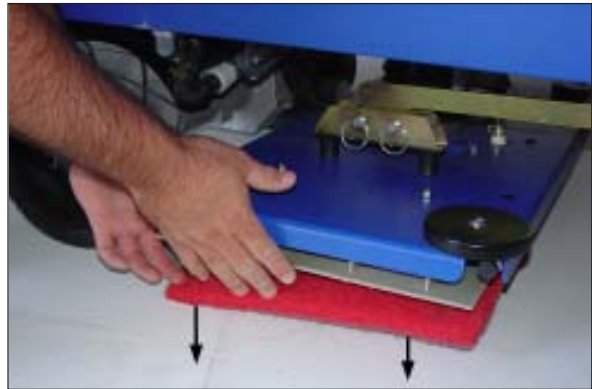

Figure 16

## How To Operate The Machine

### How to Return One Touch to Factory Default Settings

To restore the factory settings, follow the procedures below:

1. Press and hold the green one touch button (figure 17) until you hear a *double beep* from the machine. **NOTE: The time required for this will be approximately 15 seconds.**
2. The settings should be returned to 2 bars of solution and 1 bar of brush pressure. **NOTE: The squeegee vac switch must be in the middle position for default settings to work.**

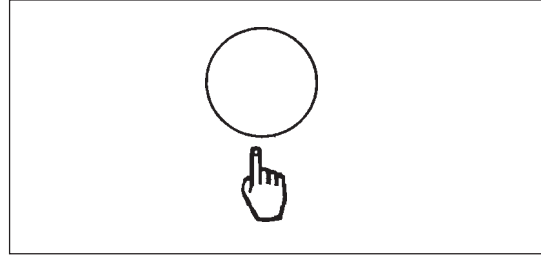

Figure 17

### How to Move the Machine Without Power (see figure 18)

1. Engage manual override on brake (see page 9, "Parking Brake").
2. Remove foot plate and 4 screws and locate steering motor.
3. Using the knob on steering motor, turn shaft on motor in direction you wish to turn machine.
4. Slowly push machine to desired location. **NOTE: If you attempt to push machine too fast it will limit top speed. If this happens, stop and restart.**
5. After moving machine, disengage manual brake override. **NOTE: Machine will not function if override is engaged.**



Figure 18

### Seat Adjustment (Standard)

The standard seat is not adjustable forward or backward.

### Seat Adjustment (Deluxe)

The optional deluxe seat is adjustable in three ways:

1. The seat can be adjusted to the forward/backward position by using the lever on the lower right side of the seat. Moving the lever will allow the seat to slide into the preferred position. See figure 19.
2. To adjust the angle of the back support portion of the seat, turn the lever located in the middle right position of the seat. Turning this clockwise will make the seat more vertical. Turning the knob counterclockwise will tilt the seat back. See figure 20 A.
3. To adjust the suspension of the seat for operator comfort, use the lever on the side of the back support section of the seat. This has three positions. The upper position is for light weight operators. The middle position is for medium weight operators. The bottom position is for heavy weight operators. See figure 20, B. **NOTE: The lever must be pressed firmly to change positions.**

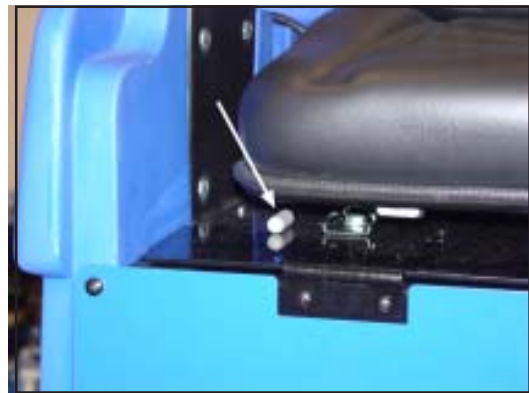

Figure 19



Figure 20



## How To Operate the Machine

### How to Read the Battery Meter (see figure 21, A)

The battery meter is an indicator on the LCD display. This indicator is on the LCD display on the front of the machine. It has 10 bars with 10 bars visible indicating a full charge. As you run the machine the bars will begin to lower. The "Battery Icon" (B) will begin to flash to indicate you are reaching the end of charge.

**NOTE: If you continue to run the brushes they will shut down to protect the batteries from over discharging.**

**NOTE: Run times will vary depending on machine variables, battery size, brush pressure and floor type, etc.**

### How to Change Displays Screens on the LCD Module

The LCD display has three screens. Two of them can be accessed at any time the key is on. The first screen shows the machine status and the second screen shows the four hour meters (figure 21).

The two screens that can be viewed by the operator can be accessed via the display button (figure 22) on the control panel to the left of the key switch. Pressing this button toggles the display between the available screens.

The third screen is for diagnostics only. This screen displays any errors that might occur or if the system diagnostics finds something wrong. When the diagnostic screen comes up, refer to the trouble shooting guide for suitable action to resolve the error code.

### How to Read the Solution Empty Indicator (see figure 23, A)

The solution empty indicator is located on the front of the machine below the LCD display. When the solution reaches nearly empty, the indicator will begin to flash, warning the operator of the need to refill.

**NOTE: Solution run times will vary depending on solution flow setting.**

### How to Read the Recovery Full Indicator (see figure 23, B)

The recovery full indicator is located on the front of the machine below the LCD display. When the recover tank is near full the indicator will begin to flash, warning the operator of the need to empty the recovery tank. The vacuum motors will shut down a few moments later.

**NOTE: Recovery times will vary depending on solution flow setting and floor type.**

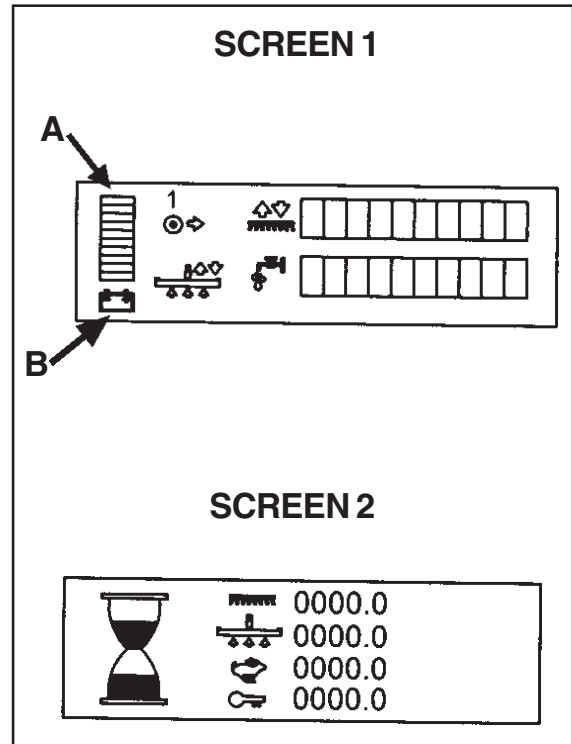

Figure 21

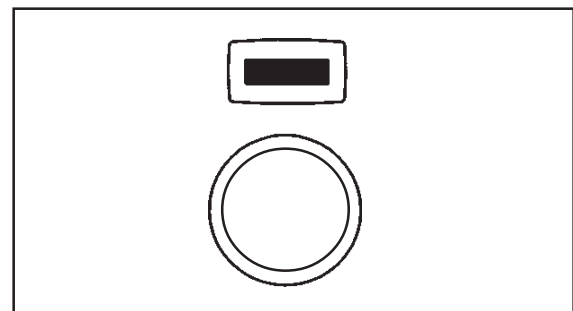

Figure 22

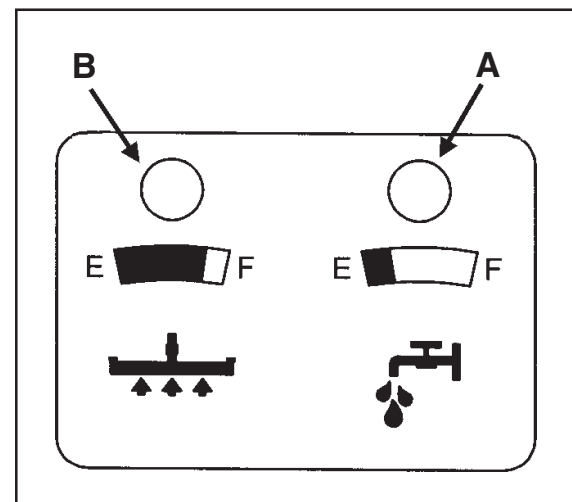

Figure 23

## How To Operate the Machine

### How to Operate the Squeegee and the Vacuum Motor

The squeegee wipes the floor while the vacuum motor removes the dirty solution from the floor. To operate the squeegee, follow this procedure:

1. To lower the squeegee and start the vacuum motor, press the squeegee up/down switch to the down position (figure 24). **NOTE: The vacuum motor will start immediately when the down position of the switch is pressed, and the squeegee will lower.**
2. To raise the squeegee, press the squeegee up/down switch to the up position (figure 24). The squeegee will then raise and the vacuum motor will shut off after short delay **NOTE: The center position of the squeegee up/down switch is for use with one touch control.**

**NOTE:** The squeegee will rise automatically when traversing in reverse during scrubbing operations.

### How to Operate the Solution Flow

The solution is used to loosen and remove dirt from the floor. The amount of solution applied can be adjusted to five different levels to accommodate many different floor conditions. These different levels are shown on the LCD display on the front of the machine. To adjust the amount of solution applied, use the Solution Flow Switch (figure 25). **NOTE: There are five different settings on the display. See figure 26, A.**

To increase solution flow:

1. Press the “+” side of the switch (figure 25).
2. Press and hold the “+” switch to achieve the desired level of solution flow.

To decrease solution flow:

1. Press the “-” side of the switch (figure 25).
2. Press and hold the “-” side of the switch to achieve the desired level of solution flow.

### How to Operate the Brush Pressure

The brushes are used to supply agitation for the solution, which improves the cleaning process. The amount of brush pressure applied can be adjusted to five different levels to accommodate many different floor conditions. These different levels are shown on the LCD display on the front of the machine (figure 26, B). To adjust the amount of brush pressure, use the brush up/down switch (figure 27).

To increase brush pressure:

1. Press the “+” side of the switch (figure 27).
2. Press and hold the “+” switch to achieve maximum level of pressure.

To decrease brush pressure:

1. Press the “-” side of the switch (figure 27).
2. Press and hold the “-” side of the switch to achieve minimum or no brush pressure.

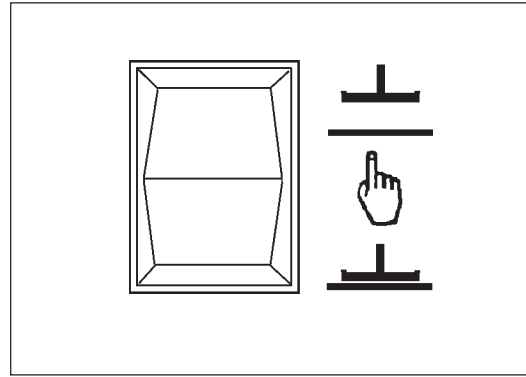

Figure 24

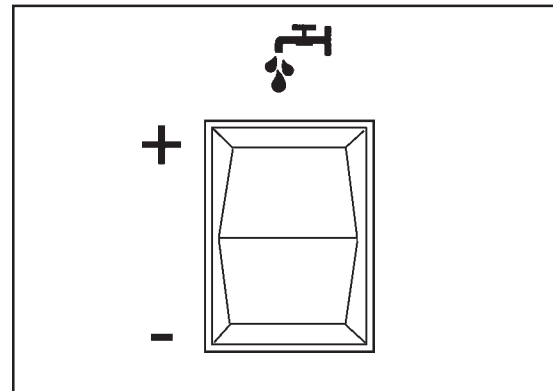

Figure 25

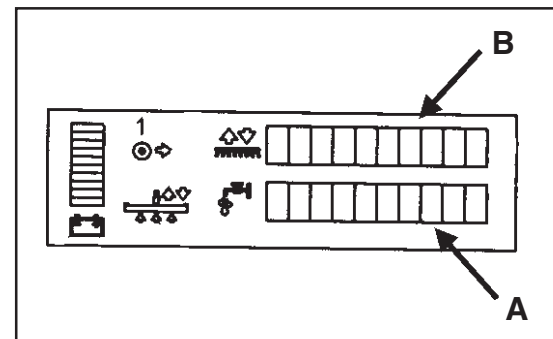

Figure 26

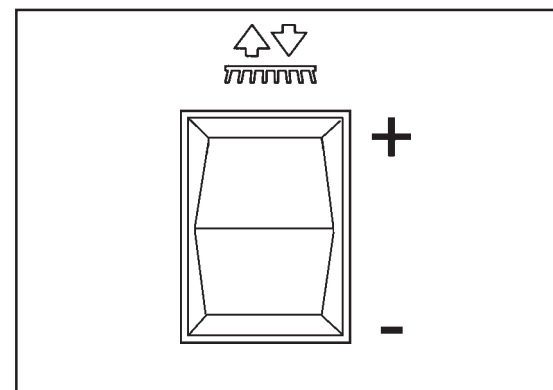

Figure 27

## How To Operate the Machine

### How to Operate the Forward / Reverse Switch

(see figure 28).

1. To go forward, push the up arrow side of the switch.
2. To go in reverse, push the down arrow side of the switch.

### How to Fill the Solution Tank

The solution tank fill port is located at the left side of the machine (see figure 29). To fill the solution tank, follow this procedure:

1. Turn the key switch to the "OFF" position.
2. Remove lid.
3. Add a cleaning chemical to the solution tank. For the correct amount of chemical, follow the directions shown on the container. **NOTE: Excess foam in the recovery tank could damage the vacuum motor, so use only the minimum amount of detergent necessary.**



**WARNING:**

Always use low foam detergent. To avoid the production of foam, before starting to clean, put a minimum quantity of antifoam liquid into the recovery tank. NEVER USE PURE ACID.

4. Fill the solution tank with clean water (see figure 29).
5. After filling the solution tank, replace the solution tank lid.



**WARNING:**

Water solutions or cleaning materials used with this type of machine can leave wet areas on the floor surface. These areas can cause a dangerous condition for the operator or other persons. Always put CAUTION signs near the area you are cleaning.



**WARNING:**

Machines can ignite flammable materials and vapors. Do not use with or near flammables such as gasoline, grain dust, solvents and thinners. Only use a cleaning concentration recommended by the chemical manufacturer.



**WARNING:**

ALTO recommends a maximum water temperature of 120°F (49°C).

### Operating the Machine

**NOTE:** Before scrubbing with the machine, become familiar with the operations and handling of the machine. Run the machine at the lowest traverse speed. Use the machine in an area that has no furniture or objects until you can do the following:

1. Traverse the machine in a straight direction, forward and backward.
2. Stop the machine safely.
3. Turn the machine both left and right and return to a straight direction.
4. Turn a 180° turn where one rear wheel just pivots.

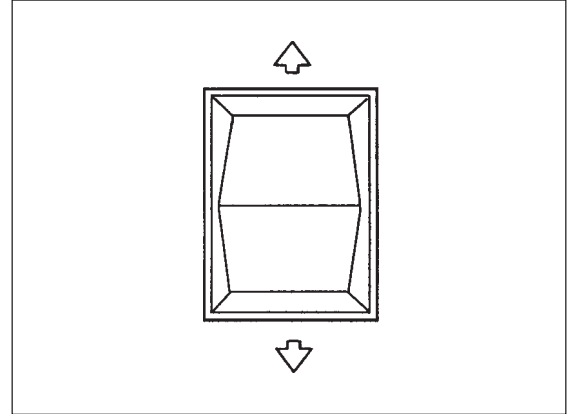

Figure 28



Figure 29

## How To Operate the Machine (cont.)

To traverse the machine follow this procedure:

1. Sit on the driver seat. **NOTE: The machine will not traverse if the operator is not properly seated.**
2. Turn the key switch to the "ON" position.
3. Raise the brush to the highest position (if necessary).
4. Raise the squeegee (if necessary).
5. Gently press the foot pedal and the machine will begin to move.
6. To stop, release pressure on the foot pedal.
7. To travel in reverse, select reverse with the forward/reverse switch.
8. To stop, release pressure on the foot pedal.
9. When you stop the machine, turn the key switch "OFF" and remove the key.

### Do These Procedures When You Begin Your Work Period

1. Make sure the key switch is in the "OFF" position.
2. Disconnect AC power from battery charger (follow charger instructions).
3. Make sure the filter screen (1) to the vacuum motor is clean and installed properly in the recovery tank (see figure 30).
4. Make sure the recovery tank lid is in place and has been tightened (see figure 31).
5. Close and secure the lower cleaning port cover (if so equipped) on the recovery tank.
6. Make sure that the plug in the recovery drain hose is in place and has been tightened (see figure 32).
7. Make sure that the brushes/pads are in position and installed correctly.
8. Make sure the brush housings are in position on the brush head.
9. Check the installation of the squeegee and squeegee hose.

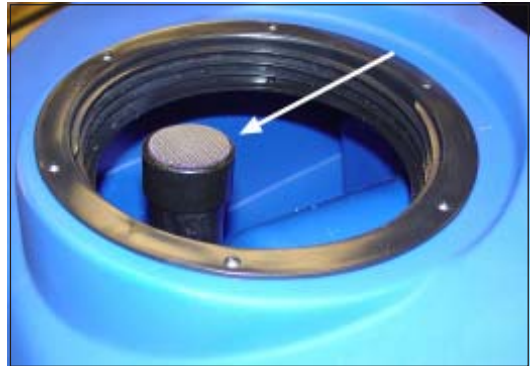

Figure 30



Figure 31



Figure 32

## How To Operate the Machine

### How to Clean a Floor

**WARNING:** Water solutions or cleaning materials used with this type of machine can leave wet areas on the floor surface. These areas can cause a dangerous condition for the operator or other persons. Always put CAUTION signs near the area you are cleaning.

For one touch automatic cleaning follow this procedure:

1. Turn the key switch to the "OFF" position.
2. Put the water and a cleaning chemical in the solution tank.
3. Sit on the driver seat. **NOTE: The machine will not traverse if the operator is not properly seated.**
4. Turn the key switch "ON". **NOTE: The key switch turns on the battery and LED screen displays, which shows the machines condition.**
5. The machine has a one touch button on the control panel (see figure 33) that is preset for brush pressure and solution flow. Momentarily depress the one touch button if you wish to use these settings. **NOTE: If this is not the settings that you desire see page 16 or one touch operation.**

For manual control of cleaning process, follow these procedures:

1. Turn the key switch to the "OFF" position.
2. Put the water and a cleaning chemical in the solution tank.
3. Sit on the driver seat. **NOTE: The machine will not traverse if the operator is not properly seated.**
4. Turn the key switch "ON". **NOTE: The key switch turns on the battery and LED screen displays, which shows the machines condition.**
5. Lower the squeegee. **NOTE: The vacuum motor will turn on when the squeegee up/down switch is placed in the lower position.**
6. Lower the brush head until it reaches the full stroke down. **NOTE: The brushes will start rotating only when the machine begins to traverse.**
7. Reset the solution flow valve by using the + / - solution switch. **NOTE: The solution will flow only if the machine is moving forward.**
8. After a few feet of scrubbing, check to see that the amount of solution being applied is correct and that the squeegee is picking up water and drying the floor. Make adjustments as required.
9. Once the machine is set properly continue to scrub until the solution low indicator comes on or until you run out of solution.

**NOTE:** When making multiple passes across the floor, overlap the brush cleaning path approximately 2 inches (5 cm) of the area already cleaned by the brush.

**NOTE:** During most cleaning procedures, apply and remove the solution in one operation.

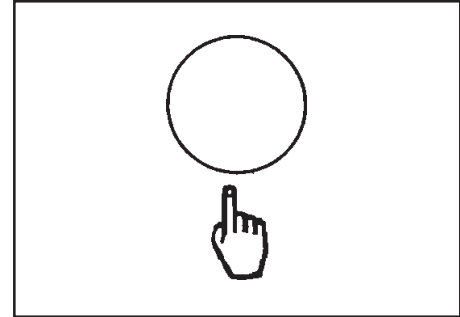

Figure 33

## How To Operate the Machine

### How to Clean a Very Dirty Floor

To clean a very dirty floor, follow this procedure:

1. Apply solution to the floor.
2. Do not lower the squeegee. This will keep the vacuum motor off.
3. Lower the brush or pad and scrub the floor.
4. Scrub the floor again with additional solution and lower the squeegee.
5. Pick up all the solution with the squeegee.



Figure 34

### Do These Procedures When You End Your Work Period

Having finished the job and before any type of maintenance is done, follow these procedures:

For one touch cleaning shut down process, press and release the one touch button.

For manual shut down follow these procedures:

1. Turn the solution flow off by decreasing the flow to its minimum position.
2. Press the brush up/down switch to the up position until the brush head has reached its up most position.
3. Place the squeegee up/down switch in the up position to raise the squeegee and allow the vacuum motor to continue to run. The vacuum motor will run for another 20 seconds and then place the squeegee up/down switch to the up position. This will shut the vacuum motor off.
4. Take the machine to a water drain.
5. Turn the key switch "OFF".
6. Remove the drain hose from the holding hook.
7. Put the end of the hose over a drain or bucket.
8. Turn the valve housing to the left (see figure 34).
9. To open the valve completely, turn the housing fully to the left. Pull the housing off of the valve.
10. Empty the recovery tank. **NOTE: When hose is lowered below water level, water will flow.**



**WARNING:**

**Use gloves to protect your hands from contact with dangerous solutions when performing the steps listed above.**

## How To Operate the Machine

11. Rinse the tank. Put clean water in the tank through the opening at the top. Be careful not to allow water into the vacuum intake tube (with screen).
12. If the tank or recovery hose has an obstruction, use water pressure to flush them. Put the water hose into the recovery hose (figure 35, A). **NOTE: Do not place water hose in vacuum intake tube (see figure 35, B), damage will occur.**

The recovery hose (figure 35, A) is located to the right of the vacuum intake tube (see figure 35, B). The recovery hose is flexible, which will allow you to move it toward the opening for easy access to the water hose for flushing the line.

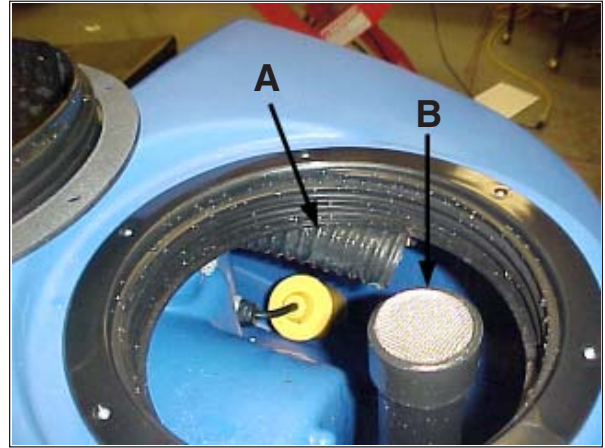

Figure 35

13. Leave the tank and drain plug removed to air dry.
14. Check the squeegee blade. Use a cloth to clean the squeegee blade. If the squeegee blade is damaged or worn, turn or replace the blade.  
**NOTE:** To avoid damage to the squeegee, the squeegee must be lifted when the machine is not in operation.
15. Take off the brushes and clean them with a jet stream of water.
16. Use a clean cloth and wipe the surface of the machine.
17. Check the batteries and add distilled water as needed. The correct level is between  $\frac{1}{4}$ " ( $\frac{1}{2}$  cm) below the bottom of the tube in each cell and above the tops of the plates. See the instructions in the section of this book called "Battery Maintenance".

**CAUTION:** Tap water may contain contaminants that will damage batteries. Batteries must be refilled with distilled water only.

**WARNING:** Lead acid batteries generate gases which can cause an explosion. NO SMOKING. Always wear eye protection and protection clothing when working near batteries.

18. Charge the batteries. See the instructions in the section of this book called "How to Charge the Batteries".

## Maintenance

### Maintenance To Be Done Every Week

- ⚠ WARNING:** Maintenance and repairs must be done by authorized personnel only. Always empty the solution tank and the recovery tank before doing any maintenance. Keep all fasteners tight.
- ⚠ WARNING:** Always wear eye protection and protective clothing when working near batteries. **NO SMOKING!** Do not put tools or other metal objects across the battery terminals or the tops of the batteries.
- ⚠ CAUTION:** To prevent damage to the machine, and discharge across the tops of the batteries, do not fill the batteries above the bottom of the tube in each cell. Wipe any acid from the machine or the tops of the batteries. Do not add acid to batteries after installation.

### Battery Inspection and Cleaning

1. Turn the key switch to the "OFF" position.
2. To inspect batteries, rotate seat support forward. Lift and rotate recovery tank. Be sure the recovery tank is empty before lifting.
3. Disconnect the batteries. Use a cloth and a solution of ammonia or bicarbonate of soda to wipe the top of the batteries. Clean the battery terminals. Reconnect the batteries. See the instructions in the section of this book called "Battery Maintenance".
4. When battery inspection is completed, close the recovery tank. Rotate the seat support back to the operating position.

### Cleaning the Recovery Tank and Filter

1. Turn the key switch to the "OFF" position.
2. Empty the recovery tank using the flexible drain hose by unscrewing the knob and taking off the plug (see figure 36).
3. If the machine is equipped with the optional clean-out port, open the lower cleaning port cover by unscrewing the four knobs (see figure 37). **NOTE: Make sure that the tank is empty first.**
4. Rinse the tank and clean the drain plug.



Figure 36



Figure 37



## Maintenance

5. Clean the hose fitting in the recovery tank and spray water down the squeegee hose to clean out debris.
6. Reattach the squeegee hose.

### Cleaning the Solution Tank and Filter

1. Move the machine so that the solution tank filter assembly is located directly over a floor drain.
2. Turn the key switch to the "OFF" position.
3. Clean inside the solution tank with a jet stream of water.
7. Close the solution flow valve.
8. Clean the filter inside the housing and reinstall on machine.

### Manually Draining the Solution Tank

1. Remove sight gauge hose from top connector (see figure 38).
2. Rotate lower fitting to allow drain hose to rest over drain.
3. Drain solution tank (see figure 39).

### Vac Assisted Solution Tank Drain

1. Remove vacuum hose from squeegee plate.
2. Turn vac on.
3. Remove and place solution hose into vac hose until washer rest against hose cuff.

**NOTE: Using vac assist will help to rinse recovery tank. This will help to reduce cleanup and maintenance times.**

### Squeegee Maintenance

Clean the squeegee with a jet stream of water and a damp cloth. Inspect the front and rear squeegee blades for wear. Readjust or replace if necessary.

### Front Squeegee Blade Replacement

To replace the front squeegee blade, follow this procedure:

1. Remove the squeegee assembly from the machine.
2. Remove clamp and front squeegee blade.
3. Install new front squeegee blade and reinstall clamp.
4. Replace squeegee on machine.



Figure 38



Figure 39

## Maintenance

### Rear Squeegee Blade Replacement

If the rear squeegee blade is worn and does not dry the floor well, follow this procedure:

1. Remove the squeegee assembly from the machine.
2. Remove the squeegee blade and inspect it.
3. Rotate the squeegee blade to obtain a new cleaning edge. Replace if necessary.
4. Reinstall the squeegee blade.
5. Reinstall the squeegee assembly on the machine.
6. Readjust the settings on the squeegee as required (see "How to Adjust Squeegee").

### Squeegee Maintenance

The squeegee blade may be rotated for longer life. Keep sharp corner on floor for best cleaning results. See figure 40. To rotate follow this procedure:

1. Remove Clamp.
2. Remove blade and rotate to new edge.
3. Replace squeegee.
4. Replace clamp.

### Cleaning the Vacuum Hoses

Make sure the squeegee is over a suitable drain.

1. Use a water hose to flush through the recovery hoses.
2. Side Squeegee - Position water hose to the squeegee side of the hose and flush thoroughly.
3. Recovery Hose - Position water hose inside recovery tank. Recovery hose is located behind threaded lip (see figure 40, A). **NOTE: Do not place hose in vacuum intake tube (see figure 41, B), damage will occur.**



Figure 40

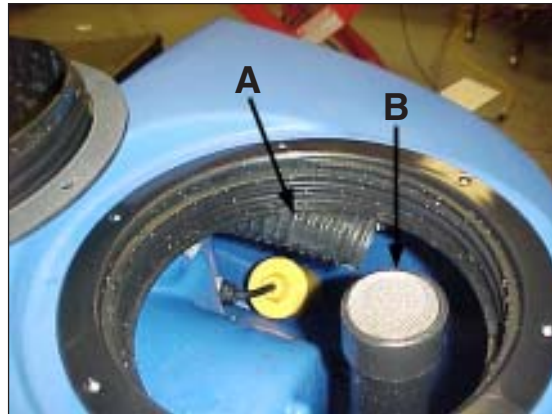

Figure 41

## HOW TO CORRECT PROBLEMS IN THE MACHINE

PROBLEM	CAUSE	ACTION
<b>Insufficient water onto the brushes</b>	<p>The solution flow is not set</p> <p>There is no water in the solution tank.</p> <p>The solution filter is dirty.</p> <p>A circuit breaker has tripped.</p> <p>Insufficient flow.</p>	<p>Make sure the solution flow is set.</p> <p>Fill the solution tank.</p> <p>Clean the solution filter.</p> <p>Reset the circuit breaker.</p> <p>Increase flow with solution switch.</p>
<b>The machine does not clean satisfactorily</b>	<p>The brushes are worn.</p> <p>Need to use a different kind of brush/pad</p>	<p>Check the brushes and replace if necessary. (the brushes have to be replaced when the bristles reach approximately .59 inches (15mm height.)</p> <p>Use a different kind of brush. For cleaning operations on floors where the dirt proves to be particularly resistant, we recommend using special brushes. See Accessories page.</p>
<b>The squeegee does not dry the floor</b>	<p>The squeegee is dirty.</p> <p>Recovery drain hose is not closed.</p> <p>The suction hoses need to be cleaned.</p> <p>The squeegee blades are worn.</p> <p>The recovery tank is full.</p>	<p>Clean the squeegee.</p> <p>Close the drain plug.</p> <p>Clean the vacuum hoses. See "Routine Maintenance" section.</p> <p>Replace/ or rotate the squeegee blades. See "Routine Maintenance" section.</p> <p>Drain recovery tank.</p>
<b>The vacuum motor does not function</b>	<p>The squeegee up/down switch in not in the low or middle position.</p>	<p>Put the squeegee in the low or middle position or reprogram "one touch".</p>
<b>The machine does not start</b>	<p>The operator is not properly seated.</p> <p>The key is not in the "ON position".</p> <p>The charger is still connected.</p> <p>The batteries are not charged or not connected properly.</p> <p>The circuit breaker has tripped.</p>	<p>The operator must be properly seated in the driving position.</p> <p>Turn the key to the "ON" position.</p> <p>Remove the A/C cord from the wall.</p> <p>Check to make sure the batteries are connected properly and charge if necessary.</p> <p>Reset the circuit breaker.</p>
<b>The brush motors do not work WARNING: To avoid damage to the floor, the motor starts only when the machine is traversing.</b>	<p>The brush head unit is not down.</p> <p>The batteries are not charged or not connected properly.</p> <p>Poor electrical connection at the brush head unit.</p>	<p>Put the brush head unit down.</p> <p>Check to make sure the batteries are connected properly and charge if necessary.</p> <p>Connect the electrical connection at the brush head unit.</p>

## Scrubtec R Common Error Codes

ERROR CODE	CAUSE	ACTION
1500 1501 1507	Check brake and wiring for short circuit.	Make sure manual override is not engaged.
1600	High battery voltage.	Poor or corroded connection to the battery.
3100 3101 3102 3103 3104 3105	Probable short circuit of output device.	Check the traction, brush and vac motor connections on the trio and check wiring from these connectors down to the traction, brush and vac motors.
7600	Open circuit on brush motors or brush motor wiring.	Check the brush motor connection on the trio and check the wiring from this connector down to the brush motor.
7602	Brush motor overload.	Scrub in lower pressure setting.
7603	Possible short circuit on brush motors or wiring.	Check the brush motor connection on the trio and check the wiring from this connector down to the brush motor.
7700	Open circuit on vacuum motor	Check connector to trio and vacuum motor
7800	Open circuit on traction motor.	Check the traction motor connection on trio and wiring down to motor.
7802	Traction motor current has exceeded current limit for the fold back time.	Excessive driving up an incline, or machine driven up against an obstacle or step.
9000	Brushes not fitted.	Place brushes or pads onto machine.
2F01	Drive system activated prior to turning key switch "ON".	Release traverse switch and reactivate.

## Accessories and Options

### BRUSHES AND PAD DRIVERS

<b>SCRUBTEC R 571 Disc Model</b>	
<b>PART NO.</b>	<b>DESCRIPTION</b>
17521C	Pad Driver Assembly (2 req.)
10383A	Lite Grit Disc Brush (2 req.)
11431B	Clean Grit Abrasive (2 req.)
11426B	Supergrit (2 req.)
11427B	Polypropylene (2 req.)
10874A	Nylon (2 req.)
<b>SCRUBTEC R 586 Disc Model</b>	
<b>PART NO.</b>	<b>DESCRIPTION</b>
17520C	Pad Driver Assembly (2 req.)
10384A	Lite Grit Disc Brush (2 req.)
11430B	Clean Grit Abrasive (2 req.)
11425B	Supergrit (2 req.)
11424B	Polypropylene (2 req.)
10875A	Nylon (2 req.)
<b>SCRUBTEC R 571 C Cylindrical Model</b>	
<b>PART NO.</b>	<b>DESCRIPTION</b>
30614A	Polypropylene (2 req.)
30615A	Nylon (2 req.)
30616A	Clean Grit Abrasive (2 req.)
30617A	Supergrit (2 req.)
30619A	Lite Grit (2 req.)
<b>SCRUBTEC R BOOST Model</b>	
<b>PART NO.</b>	<b>DESCRIPTION</b>
997004	Pads, Red 14 x 32 (5 Pack)
997003	Pads, Black 14 x 32 (5 Pack)
997005	Pads, White 14 x 32 (5 Pack)
997007	Pads, Blue 14 x 32 (5 Pack)

### SQUEEGEE BLADES

<b>SCRUBTEC R 571 Disc Model</b>	
<b>PART NO.</b>	<b>DESCRIPTION</b>
30556A	Rear Squeegee, Back Gum Rubber Blade
30067L	Rear Squeegee, Back Linatex Blade
30066A	Rear Squeegee, Front Ribbed Urethane Blade
30540A	Side Squeegee, Back Gum Rubber Blade
30540L	Side Squeegee, Back Linatex Blade
30541A	Side Squeegee, Front Ribbed Urethane Blade
<b>SCRUBTEC R 586 Disc &amp; 571 C Cylindrical Model</b>	
<b>PART NO.</b>	<b>DESCRIPTION</b>
30557A	Rear Squeegee, Back Gum Rubber Blade
30069L	Rear Squeegee, Back Linatex Blade
30091A	Rear Squeegee, Front Ribbed Urethane Blade
30540A	Side Squeegee, Back Gum Rubber Blade
30540L	Side Squeegee, Back Linatex Blade
30541A	Side Squeegee, Front Ribbed Urethane Blade
<b>SCRUBTEC R BOOST Model</b>	
<b>PART NO.</b>	<b>DESCRIPTION</b>
30773L2	Inner Blade, Linatex 3/16
38727A	Inner Blade, Urethane Ribbed
30774A	Outer Blade, Gum Rubber
30774L	Outer Blade, Linatex 3/16

### FIELD INSTALLED OPTION KITS

<b>PART NO.</b>	<b>DESCRIPTION</b>
10880A	ESP - Extra Scrub Productivity, Recycling
10881A	Off Aisle Spray Tool and Vac Wand (includes pump)
10876A	Solution and Recovery Tank Level Indicator Lights
10877A	Caution Strobe Light (Amber)
10878A	Deluxe Seat
10879A	Head Light
53390A	CBMS - Clarke Battery Maintenance System





**Manual Steering Models**  
**SCRUBTEC R 571**  
**SCRUBTEC R 571 C**  
**SCRUBTEC R 586**  
**SCRUBTEC *BOOST* R**  
Section II  
**Parts and Service Manual**

(71274A)

U.S. Patent No. 6,105,192; No. RE39,581; No. 6,557,207; No. 7,185,397; and Patents Pending

CLARKE TECHNOLOGY  
**SCRUBTEC R 571, 586, 571 C, BOOST® R**  
Final Assembly Drawing 10/06

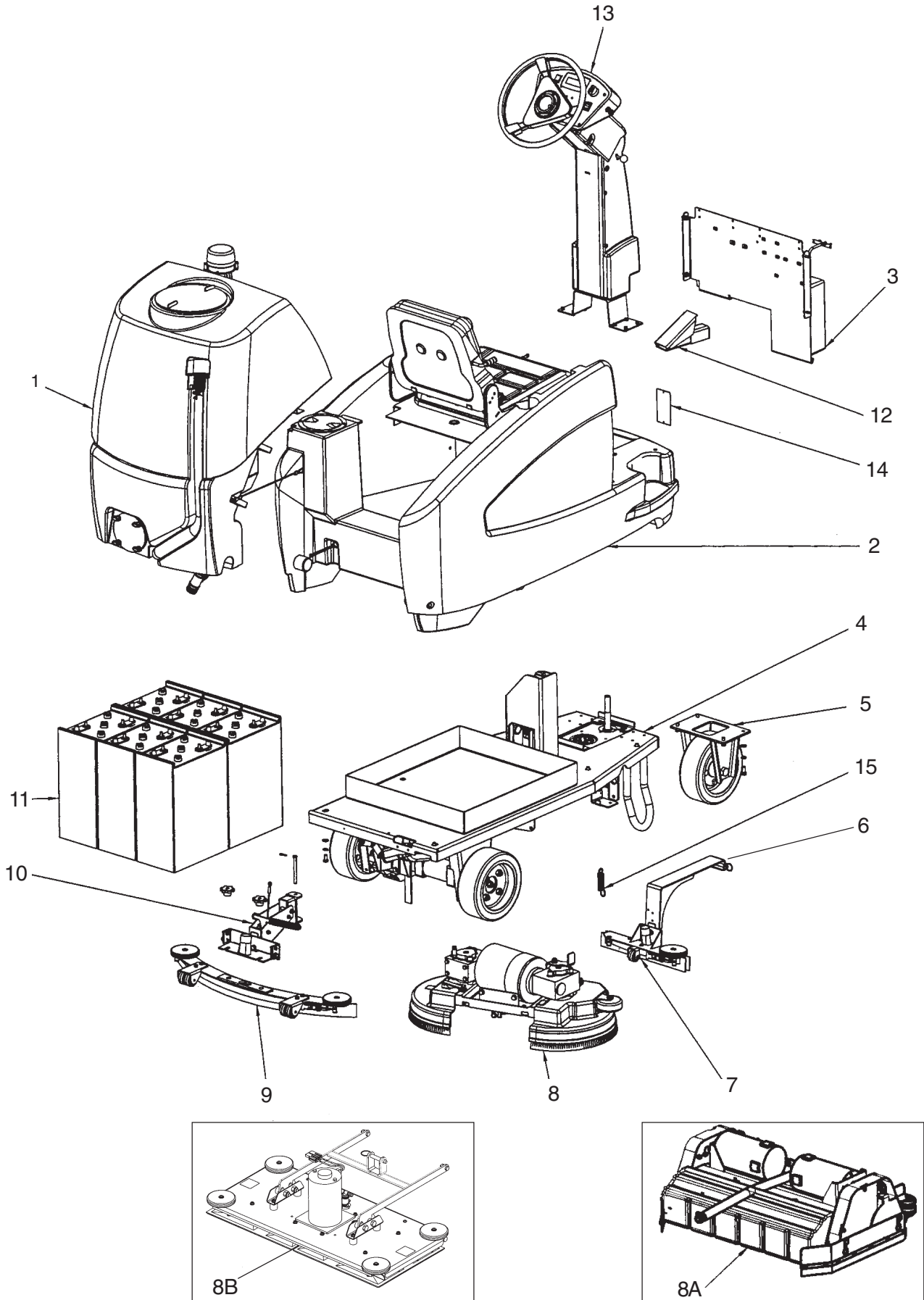



**CLARKE TECHNOLOGY**  
**SCRUBTEC R 571, 586, 571 C, BOOST® R**  
Final Assembly Parts List 10/06

Ref	Part No.	Description	Qty Rotary	Qty Cyl.	Qty. Boost
1	pg 44-45	Tank, Recovery (Assembly)	1	-	-
	pg 44-45	Tank, Recovery (Assembly)	-	1	1
2	pg 46-49	Tank, Solution (Assembly)	-	-	1
	pg 46-49	Tank, Solution (Assembly)	1	1	-
3	pg 62	Plate, Electrical (28")	1	-	-
	pg 62	Plate, Electrical (34")	1	-	-
	pg 62	Plate, Electrical (Cyl.)	-	1	-
	pg 62	Plate, Electrical (Boost)	-	-	1
4	pg 34-35	Mainframe, Main Asm. (Rotary)	1	-	-
	pg 38-39	Mainframe, Main Asm. (Boost)	-	-	1
	pg 36-37	Mainframe, Main Asm. (Cyl.)	-	1	-
5	pg 42	Wheel, Front Steering	1	1	1
6	pg 61	Arm, Sec. Squeegee Lift	1	-	-
7	pg 60	Squeegee, Secondary	1	-	-
8	pg 52	Assembly, 28" Rotary Brush Head	1	-	-
	pg 53	Assembly, 34" Rotary Brush Head	1	-	-
	8A pg 54-55	Assembly, 28" Cyl. Brush Head	-	1	-
	8B pg 56-57	Assembly, 32" Boost Head	-	-	1
9	10129L	Assembly, Squeegee 32"	1	-	-
	10068L	Assembly, Squeegee 41"	1	1	1
10	pg 43	Arm, Rear Squeegee Lift	1	1	1
11	40704A	Pack, Battery 370 A.H.	1	1	1
12	53767A	Pedal, Accelerator	1	1	1
13	pg 50-51	Column, Steering Asm.	1	1	1
14	70079A	Plate, Warning	1	-	1
15	818381	Spring Extension	1	-	-
NI	40895A	Positive Cable	1	1	1
NI	40896A	Negative Cable	1	1	1
NI	40882A	Cable Fuse	1	1	1
NI	41217A	Cable, Series	4	4	4

NI= Not illustrated

**CLARKE TECHNOLOGY**  
**SCRUBTEC R 571, 586**  
 Main Frame Assembly Drawing (Rotary) 9/06  
 Drawing #11098A

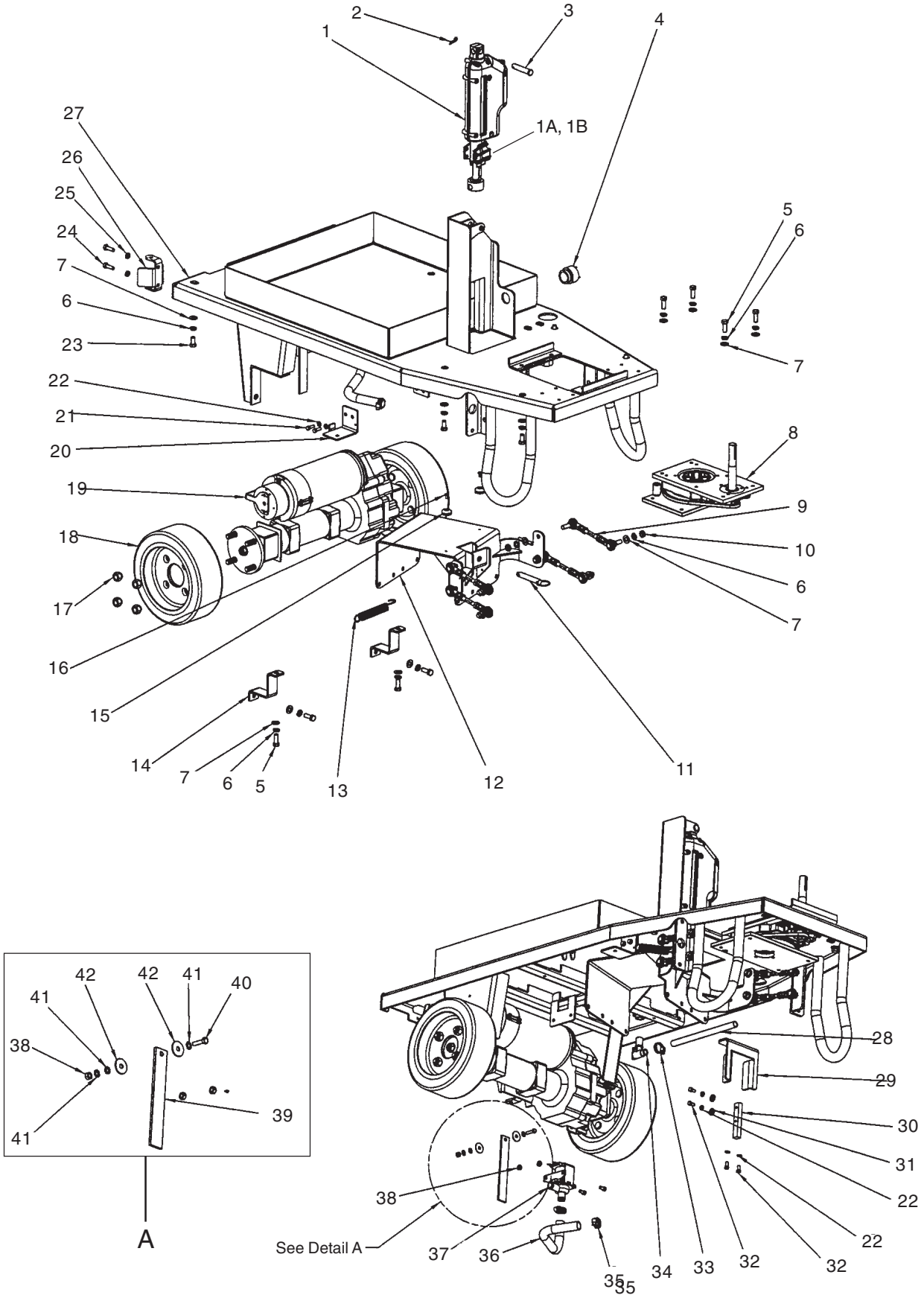

**CLARKE TECHNOLOGY**  
**SCRUBTEC R 571, 586**  
Main Frame Assembly Parts List (Rotary) 5/07  
Drawing #11098A

Ref	Part No.	Description	Qty
1	53386B	Actuator, Head Lift	1
1A	40910A	Potentiometer & Circuit Board	1
1B	40866A	Housing Potentiometer	1
2	766780	Pin, Hair	1
3	82501A	Pin, Clevis	1
4	40889A	Horn	1
5	962288	Bolt, 3/8-16 x 1 Hex Hd	8
6	170883	Washer, Lock 3/8"	22
7	980645	Washer, 3/8" S.A.E. Flat	22
8	53760A	Steering Asm. , Manual	1
9	61473A	Linkage, Rod	4
10	920204	Nut, 3/8-24 Hex Jam	8
11	53493A	Pin, Quick Release Act. Btm.	1
12	61482A	Weldment, Head Carriage	1
13	818381	Spring, Idler Tension	1
14	61475A	Clamp, Transaxle	2
15	51609A	Bumper, Rear	2
16	962929	Screw, 10-32 x 3/8"	2
17	81221A	Nut, 1/2-20 Lug	8
18	61382A	Wheel, Anti-Skid	2
19	40868A	Transaxle	1
20	61572A	Mount, Front Squeegee	1
21	962086	Screw, 1/4-20 x 3/4 Hex Hd.	2
22	980657	Washer, Lock 1/4	6
23	962244	Bolt, 3/8-16 x .75 Hex	6
24	85813A	Screw, 5/16-18 x 1 Hex Hd.	2
25	980652	Washer, 5/16 Lock	2
26	61491A	Bracket, Squeegee Stop	1
27	61481A	Weldment, Mainframe	1
28	30453A	Hose, Clear Vinyl	1
29	61596A	Stop, Brush Head	1
30	30558A	Pad, Brush Carriage Stop	1
31	87026A	Washer, 1/4 Flat SS	2
32	85737A	Screw, 1/4-20 x 1/2 HHCS	6
33	50248A	Clamp, Hose	1
34	59614A	Valve, Battery Drain	1
35	722030	Clamp, Hose	2
36	30445A	Hose, Solution (Flex)	1
37	48703A	Valve, Electric	1
38	81104A	Nut, 1/4" Nylock	3
39	69639A	Strap, Static	1
40	85700A	Screw, 1/4-20 x 1 HHCS	1
41	980614	Washer, 1/4" Starlock Ext.	3
42	980205	Washer, .31 I.D. x 1.06 O.D.	2

**CLARKE TECHNOLOGY**  
**SCRUBTEC R 571C**  
 Main Frame Assembly Drawing 9/06  
 Drawing #10949S

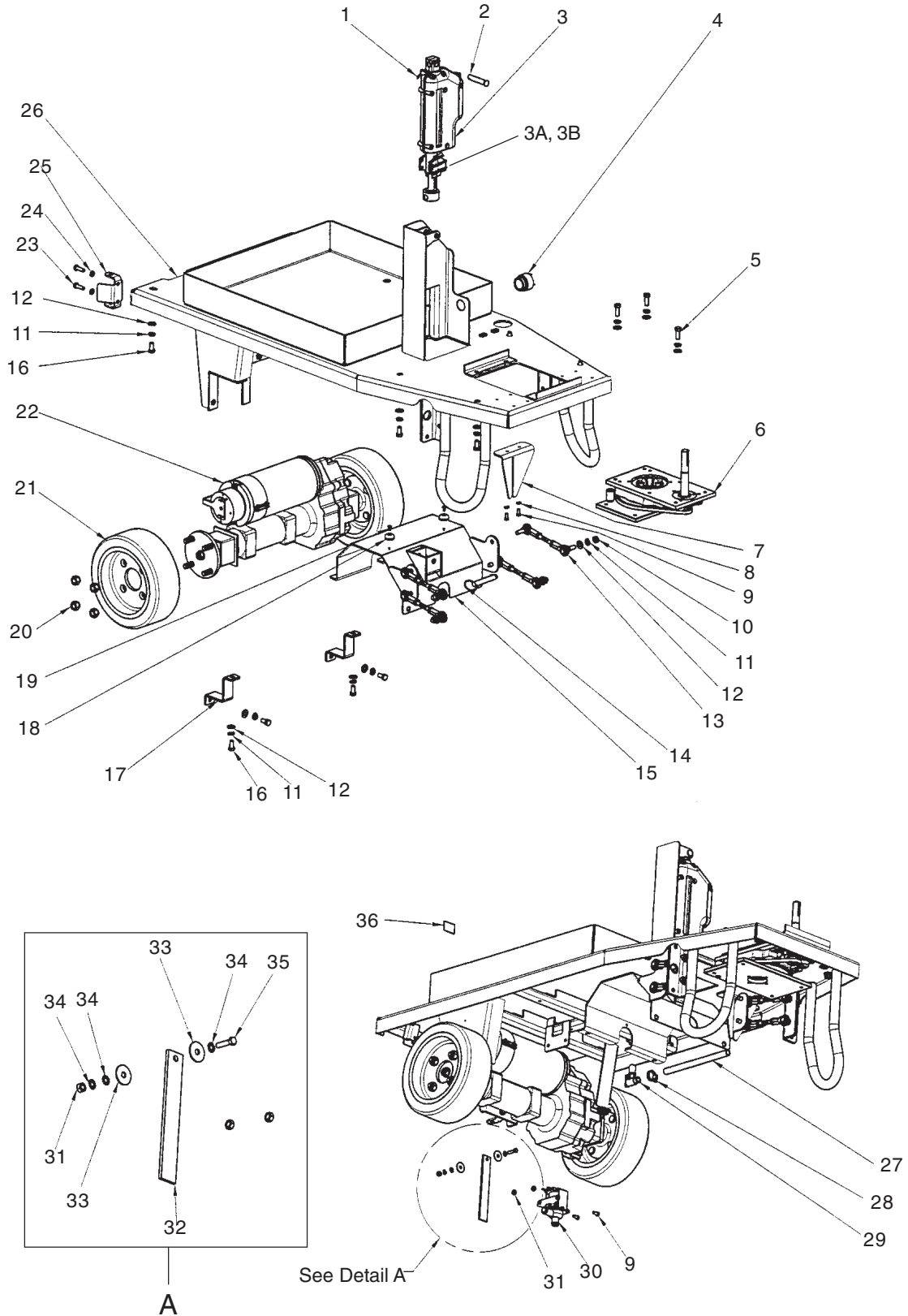

**CLARKE TECHNOLOGY**  
**SCRUBTEC R 571C**  
Main Frame Assembly Parts List 9/06  
Drawing #10949S

Ref	Part No.	Description	Qty
1	766780	Pin, Hair	1
2	82501A	Pin, Clevis	1
3	40771A	Actuator, Head Lift	1
3A	40910A	Potentiometer & Circuit Board	1
3B	40866A	Housing Potentiometer	1
4	40889A	Horn	1
5	962288	Bolt, 3/8-16 x 1 Hex Hd.	3
6	53760A	Steering Asm, Manual	1
7	61736A	Bracket, Head Stop (Cyl.)	1
8	980657	Washer, Lock 1/4	2
9	85737A	Screw, 1/4-20 x 1.2 HHCS	4
10	920204	Nut, 3/8-24 Hex Jam	4
11	170883	Washer, Lock 3/8"	17
12	980645	Washer, 3/8" SAE Flat	17
13	61473A	Linkage, Rod	4
14	53493A	Pin, Quick Release Actuator Btm.	1
15	61718A	Carriage, Weldment	1
16	962244	Bolt, 3/8-16 x .75 Hex	10
17	61475A	Clamp, Transaxle	2
18	51609A	Bumper, Rear	2
19	962929	Screw, 10-32 x 3/8"	2
20	81221A	Nut, 1/2-20 Lug	8
21	61382A	Wheel, Anti-Skid	2
22	40868A	Transaxle	1
23	85813A	Screw, 5/16-18 x 1 Hex Hd.	2
24	980652	Washer, 5/16 Lock	2
25	61836A	Bracket, Squeegee Stop	1
26	61719A	Frame, Main Weldment	1
27	30453A	Hose, Clear Vinyl	1
28	50248A	Clamp, Hose	1
29	59614A	Valve, Battery Drain	1
30	48703A	Valve, Electric	1
31	81104A	Nut, 1/4" Nylock	3
32	69639A	Strap, Static	1
33	980205	Washer, .31 I.D. X 1.06 O.D.	2
34	980614	Washer, 1/4" Starlock, Ext.	3
35	85700A	Screw, 1/4-20 x 1 HHCS	1
36	413754	Grip, Solution Tank Clamp	1

**CLARKE TECHNOLOGY**  
**SCRUBTEC BOOST® R**  
 Main Frame Assembly Drawing 3/08  
 Drawing #11107A

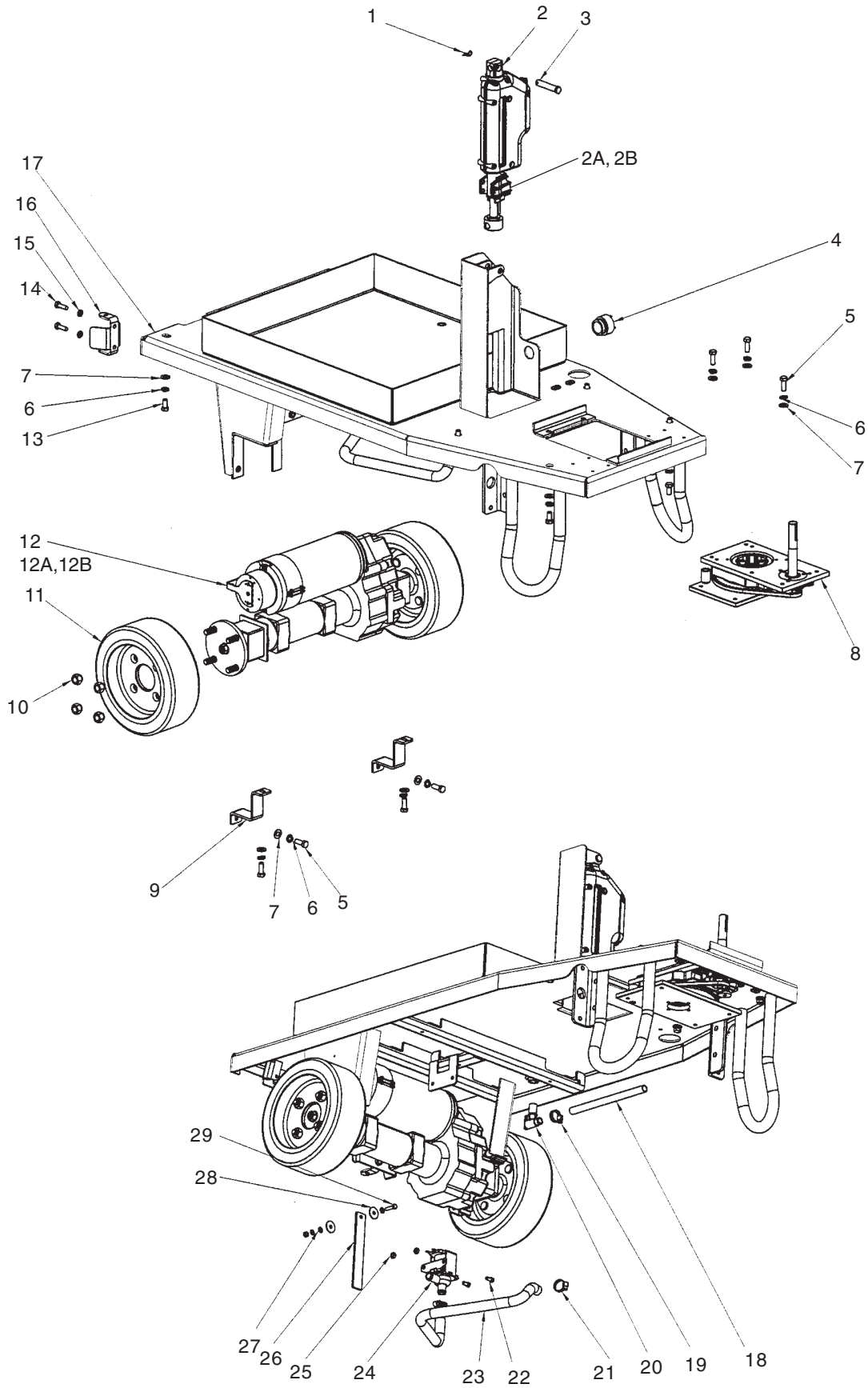

**CLARKETECHNOLOGY**  
**SCRUBTEC BOOST® R**  
Main Frame Assembly Parts List 3/08  
Drawing#11107A

Ref	Part No.	Description	Qty
1	766780	Pin, Hair	1
2	53874A	Actuator, Head Lift	1
2A	40910A	Potentiometer & Circuit Borad	1
2B	40866A	Housing Potentiometer	1
3	82501A	Pin, Clevis	1
4	40889A	Horn	1
5	962288	Bolt, 3/8-16 x 1 Hex Hd.	7
6	170883	Washer, Lock 3/8"	14
7	980645	Washer, 3/8" S.A.E. Flat	14
8	53760A	Steering Asm., Manual	1
9	61475A	Clamp, Transaxle	2
10	81221A	Nut, 1/2-20 Lug	8
11	61382A	Wheel, Anti-Skid	2
12◆	40837A	Transaxle	1
12A◆	40798A	Brake	1
12B◆	41020A	Motor	1
13	962244	Bolt, 3/8-16 x .75 Hex	7
14	85813A	Screw, 5/16-18 x 1 Hex Hd.	2
15	980652	Washer, 5/16 Lock	2
16	61836A	Bracket, Squeegee Stop	1
17	61719A	Frame, Main Weldment	1
18	30453A	Hose, Clear Vinyl	1
19	50248A	Clamp, Hose	1
20	59614A	Valve, Battery Drain	1
21	722030	Clamp, Hose	2
22	85737A	Screw, 1/4-20 x 1/2 HHCS	2
23	30680A	Hose, Solution (Flex)	1
24	48703A	Valve, Electric	1
25	81104A	Nut, 1/4" Nylock	3
26	69639A	Strap, Static	1
27	980614	Washer, 1/4" Starlock Ext.	3
28	980205	Washer, .31 I.D. x 1.06 O.D.	2
29	85700A	Screw, 1/4-20 x 1 HHCS	1

NOTE: ◆ indicates a change has been made since the last publication of this manual.

CLARKE TECHNOLOGY  
**SCRUBTEC R 571, 586**  
Optional Side Squeegee Lift Assembly Drawing 5/05

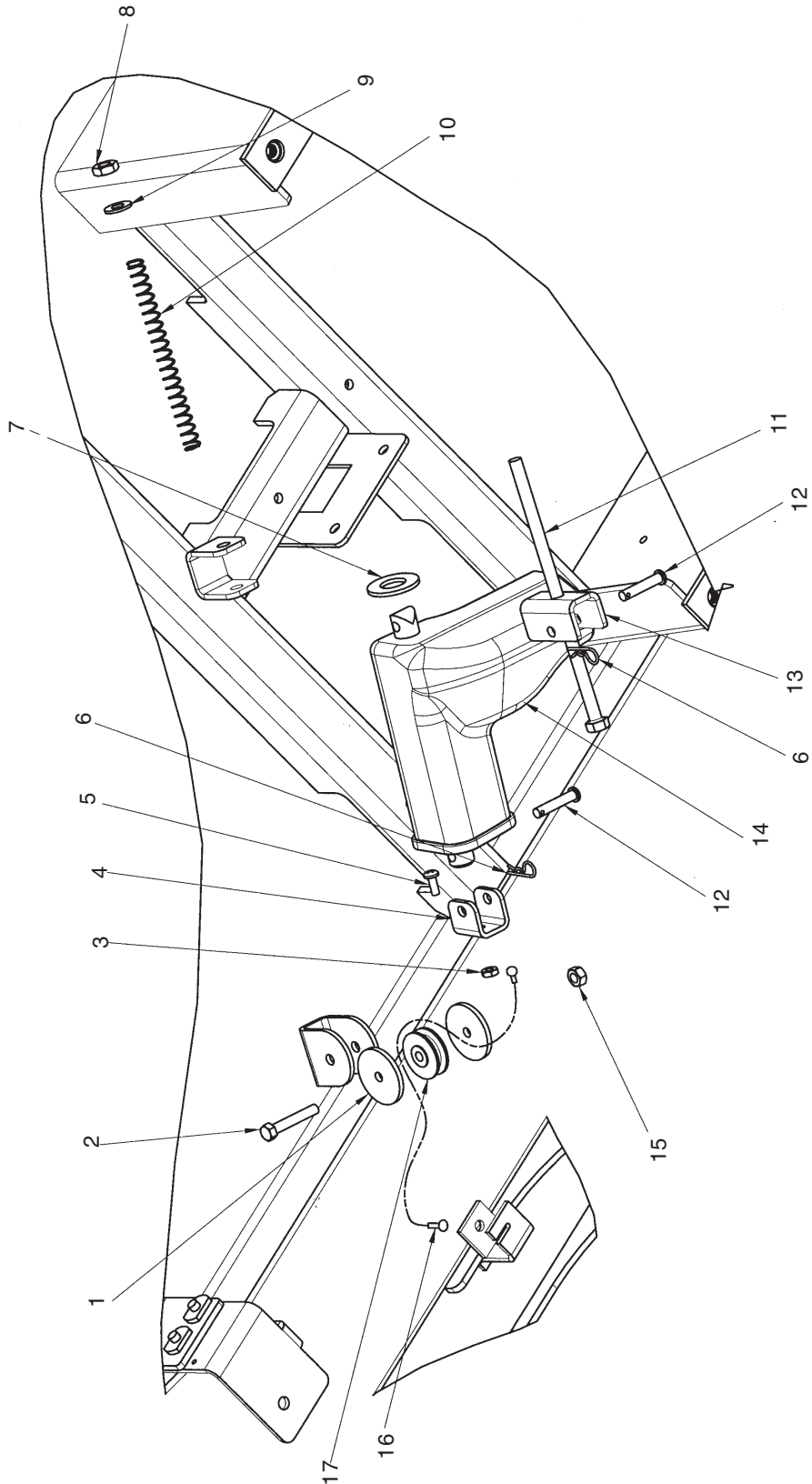



**CLARKE TECHNOLOGY**  
**SCRUBTEC R 571, 586**  
Optional Side Squeegee Lift Assembly Parts List 5/05

<b>Ref</b>	<b>Part No.</b>	<b>Description</b>	<b>Qty</b>
1	87624A	Washer, Nylon 1 1/2 x 1/4 x 1/8	2
2	86004A	Screw, 1/4-20 x 1.50 HHCS	1
3	920296	Nut, 10-24 Elastic Stop	1
4	61699A	Bracket, Sq. Lift Cable	1
5	962798	Screw, 10-24 x 1/2 PH	1
6	836711	Pin, Hair	2
7	80152A	Washer, Flat 5/8	1
8	920110	Nut, 5/16-18 Hex Lock	1
9	980651	Washer, 5/16 Flat	1
10	80286A	Spring, Actuator	1
11	80287A	Screw, 5/16-18 x 7 Hex Head	1
12	80273A	Pin, Clevis	2
13	61698A	Bracket, Actuator Rear Mount	1
14	40751A	Actuator, 3" Stroke	1
15	81104A	Nut, 1/4" Nylock	1
16	61695A	Cable, Squeegee Lift	1
17	57275A	Pulley, Cable	1

**CLARKE TECHNOLOGY**  
**SCRUBTEC R 571, 586, 571 C, BOOST® R**  
 Front Wheel Assembly Drawing and Parts List 6/07  
 Drawing #10779A

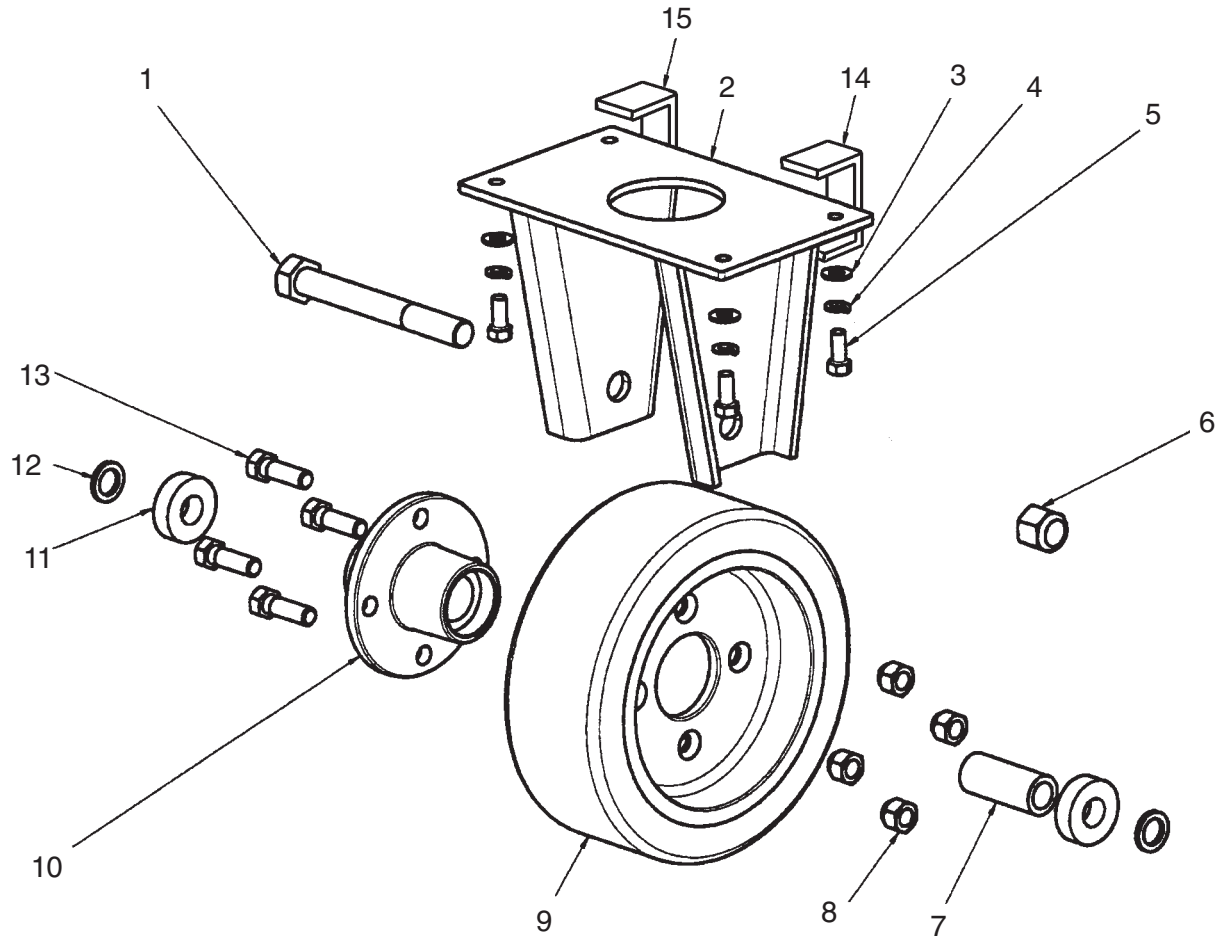

Ref	Part No.	Description	Qty
1	80267A	Bolt, 3/4 - 16 Hex Head	1
2	61472A	Yoke Weldment, Steering	1
3	980645	Washer, 3/8 Flat	4
4	170883	Washer, Lock 3/8	4
5	85822A	Screw, 3/8 -16 x 7/8 Hex Hd.	4
6	80268A	Nut, .750 ESNA	1
7	*	Spacer, Center (included w/#10)	1
8	81221A	Nut, 1/2 -20 Lug	4
9	61382A	Wheel, Anti-Skid	1
10	61691A*	Hub Assembly, Front Wheel	1
11	*	Bearing (included w/#10)	2
12	*	Spacer (included w/#10)	2
13	85838A	Bolt, 1/2 -20 Hex	4
14	61877A	Stop, LH Steering	1
15	61878A	Stop, RH Steering	1

\*Front Wheel Hub Assembly (61691A) includes reference #'s 7, 11 and 12.

**CLARKE TECHNOLOGY**  
**SCRUBTEC R 571, 586, 571 C, BOOST® R**  
 Squeegee Lift Assembly Drawing and Parts List 4/06  
 Drawing #10787A

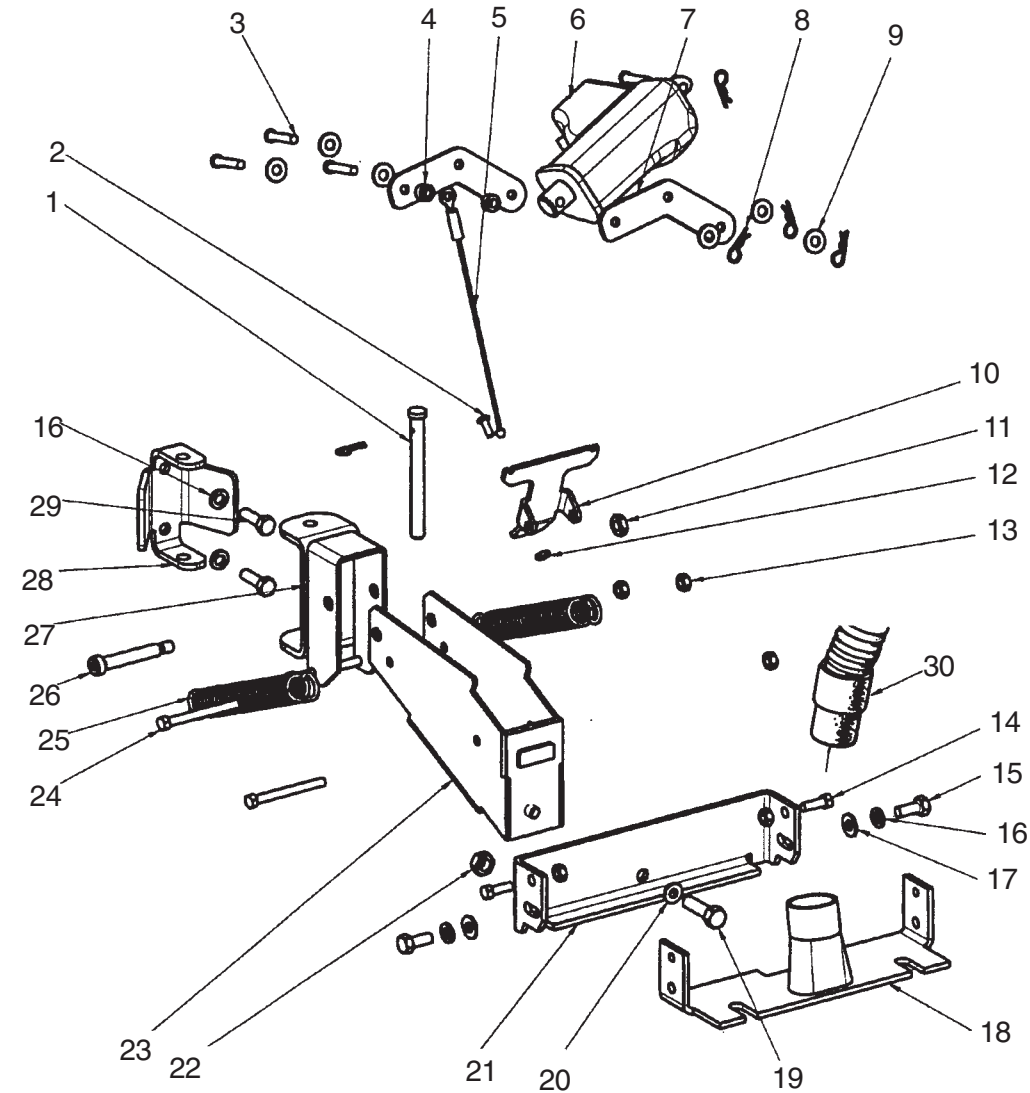

Ref	Part No.	Description	Qty
1	66531A	Pin, Swing Arm	1
2	962798	Screw, 10-24 x 1/2 PH	1
3	80273A	Pin, Clevis	4
4	30542A	Spacer	2
5	61549A	Cable, Rear Squeegee	1
6	53387A	Actuator, Squeegee	1
7	53446A	Lever, Pivot, Squeegee	2
8	836711	Pin, Hair	5
9	87026A	Washer, 1/4 Flat SS	6
10	61552A	Lever, Spring	1
11	920110	Nut, 5/16-18 Hex Lock	1
12	920296	Nut, 10-24 Elastic Stop	1
13	81104A	Nut, 1/4 Nylock	5
14	170915	Screw, 1/4 - 20 x 3/4 Hex HD	2
15	962620	Screw, 5/16 - 24 x 3/4 Hex HD	2

Ref	Part No.	Description	Qty
16	980652	Washer, 5/16 Lock	4
17	980651	Washer, 5/16 Flat	2
18	61267A	Tube, Bracket Squeegee	1
19	85730A	Screw, 3/8 - 16 x 1 1/4 Hex HD	1
20	87031A	Washer, 3/8 Flat SS	1
21	60678C	Bracket, Squeegee Mount	11
22	81105A	Nut, 3/8 - 16 SS ESNA	1
23	61551A	Arm, Rear Weldment	1
24	962269	Screw, 1/4 - 20 x 2 1/2 Hex HD	2
25	53423a	Spring, Extension 5,19"	2
26	80015A	Screw, 3/8 - 16 x 2	2
27	61550A	Mount, Front Arm	1
28	61491A	Bracket, Squeegee Mount (Rotary)	1
	61736A	Bracket, Squeegee Mount (Cylindrical)	1
29	85813A	Screw, 5/16 - 18 x 1 Hex HD	2
30	30568A	Hose, Recovery	1

CLARKE TECHNOLOGY  
**SCRUBTEC R 571, 586, 571 C, BOOST® R**  
Recovery Tank Assembly Drawing 6/07  
Drawing #10783A & 10990A

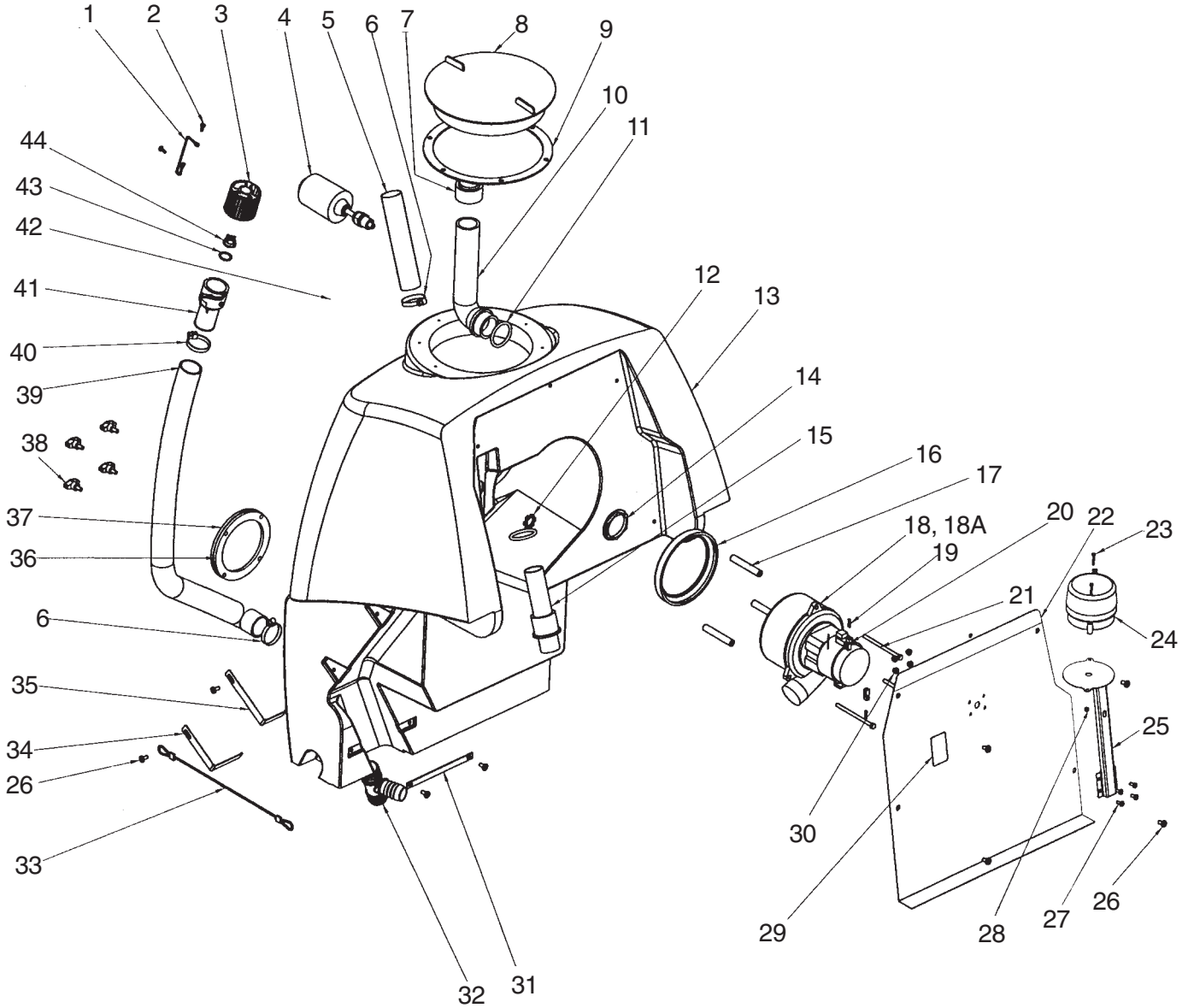

**CLARKE TECHNOLOGY**  
**SCRUBTEC R 571, 586, 571 C, BOOST® R**  
Recovery Tank Assembly Parts List 6/07  
Drawing # 10783A & 10990A

Ref	Part No.	Description	Qty
1	52206A	Chain, Drain Asm.	1
2	962957	Screw, 10 -16 x 1/2 Self Tab	2
3	30227A	Housing, Drain	1
4	40002A	Switch, Float Electrical	1
5	30622A	Hose, Vac Exhaust	1
6	752020	Clamp, Hose	1
7	58069A	Screen, Vac Filter	1
8	30581A	Lid, Recovery Tank	1
9	30582A	Gasket, Rec. Tank Lid	1
10	39339B	Tube, Stand 90°	1
11	837304	O-Ring, Retainer	2
12	82100A	Locknut, 1/02	1
13	30709A	Tank, Recovery (571 model)	1
	30710A	Tank, Recovery (586 model)	1
	30711A	Tank, Recovery (571 C model)	1
14	920797	Nut, Drain Valve	1
15	30623A	Tube, Stand Straight	1
16	643418	Gasket, Vac Unit	1
17	58533A	Spacer, Vac Motor	3
18	45019A	Motor, Vac`	1
18A	40830A	Carbon Brush	2
19	41809A	Contact, Housing Connector	2
20	43401A	Housing, Connector	2
21	85728A	Screw, 1/4 - 20 x 4 Hex HD	3
22	61565A	Panel, Recovery Vac Motor	1
23*	962212	Screw, 6-32 x 7/8 PH	2
24*	40874A	Light, Strobe	1
25*	61579A	Bracket, Strobe Light	1
26	85395A	Screw, 1/4 - 20 x 1/2 PH	8
27*	84237A	Screw, 10-32 x .50 PH	4
28	920056	Nut, 6-32 ESNA Nylock	2
29	77093A	Label	1
30*	920722	Nut, 10-32 ESNA	4
31	61478A	Retainer, Lower Hose	1
32	30561A	Coupler, Hose (Rotary Machine)	1
	682408	Connector, Hose (Cyl. & BOOST)	1
33	61573A	Cable, Recovery Tank	1
34	61498A	Retainer, Mid Hose	1
35	61477A	Retainer, Upper Hose	1
36*	30559A	Gasket, Clean Out	1
37*	61566A	Clean-Out, Drain	1
38*	52477A	Knob, 1/4 - 20 Clamp	4
39	30443A	Hose, Recovery	1
40	832002	Clamp, Hose	2
41	30225A	Body, Drain Valve	1
42*	40876A	Sensor, Water Level	1
43	52560A	O-Ring, .103 x 7.99 ID	1
44	30226A	Plug, Drain	1
NI	30568A	Hose, Squeegee	1
NI	30567A	Hose, Vac	1

NOTE: \* Optional accessories

NI = Not illustrated

CLARKE TECHNOLOGY  
**SCRUBTEC R 571, 586, 571 C, BOOST® R**  
 Solution Tank Assembly Drawing (View 1 of 2) 11/06  
 Drawing # 11099A

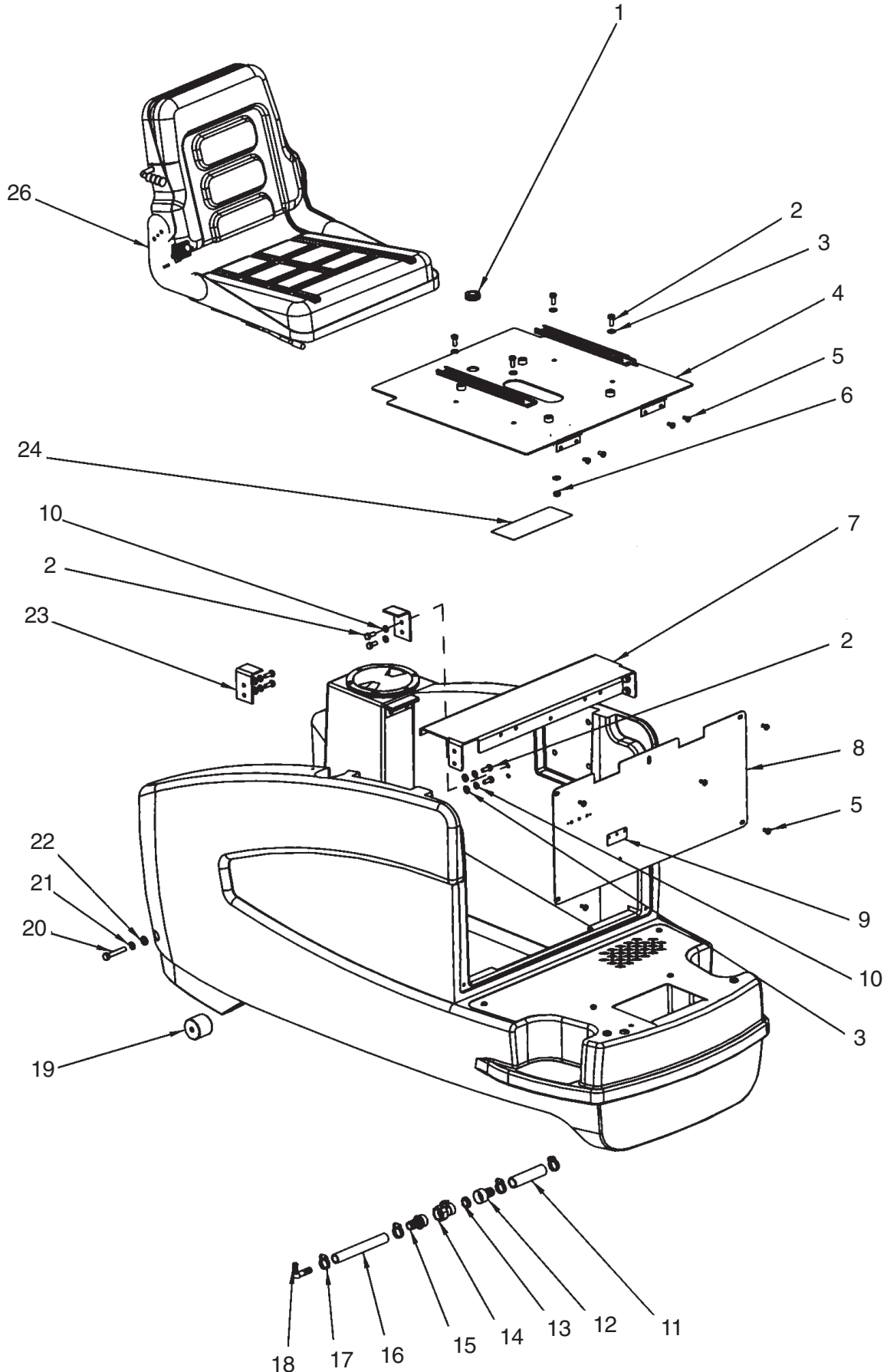

**CLARKE TECHNOLOGY**  
**SCRUBTEC R 571, 586, 571 C, BOOST® R**  
 Solution Tank Assembly Parts List (View 1 of 2) 5/07  
 Drawing# 11099A

Ref	Part No.	Description	Qty
1	193944	Grommet	1
2	85811A	Screw, 5/16 - 18 x 3/4 Hex Head	12
3	980651	Washer, 5/16 Flat	13
4	61492B	Plate, Seat Assembly	1
5	85395A	Screw, 1/4-20 x 1/2 PH	9
6	81112A	Nut, 5/16 - 18 Thin ESNA	1
7	61490A	Mount, Seat Assembly	1
8	61489A	Plate, Cover	1
9	70883A	Label, Battery Charger	1
10	980652	Washer, 5/16 Lock	8
11	30566A	Hose, 5/8" ID x 7/8" OD x 4.00	1
12	50358A	Adapter, 5/8 Barb Swivel	1
13	838517	Screen, Hose Washer	1
14	54088A	Valve, Shut-Off 3/4 GHT x 3/4 GHT	1
15	830214	Adapter, 3/4 Barb & GHT Male	1
16	30445A	Hose, Solution (Flex)	1
17	53571A	Clamp, Hose	4
18	53498A	Fitting, 90d ELL Pipe	1
19	61561A	Pivot, Recovery Tank	1
20	85704A	Screw, 3/8-16 x 2 1/4" Hex	2
21	170883	Washer, Lock 3/8"	2
22	980645	Washer, 3/8" SAE Flat	2
23	61562A	Stop, Seat	2
24	70841A	Label, Battery Installation	1
26	30534B	Seat, Ergo/Adjustable	1
NI	61573B	Cable, Seat/Rec. Tank	1
NI	50248A	Clamp, Hose	1

CLARKE TECHNOLOGY  
**SCRUBTEC R 571, 586, 571 C, BOOST® R**  
Solution Tank Assembly Drawing (View 2 of 2) 9/06  
Drawing # 11099A

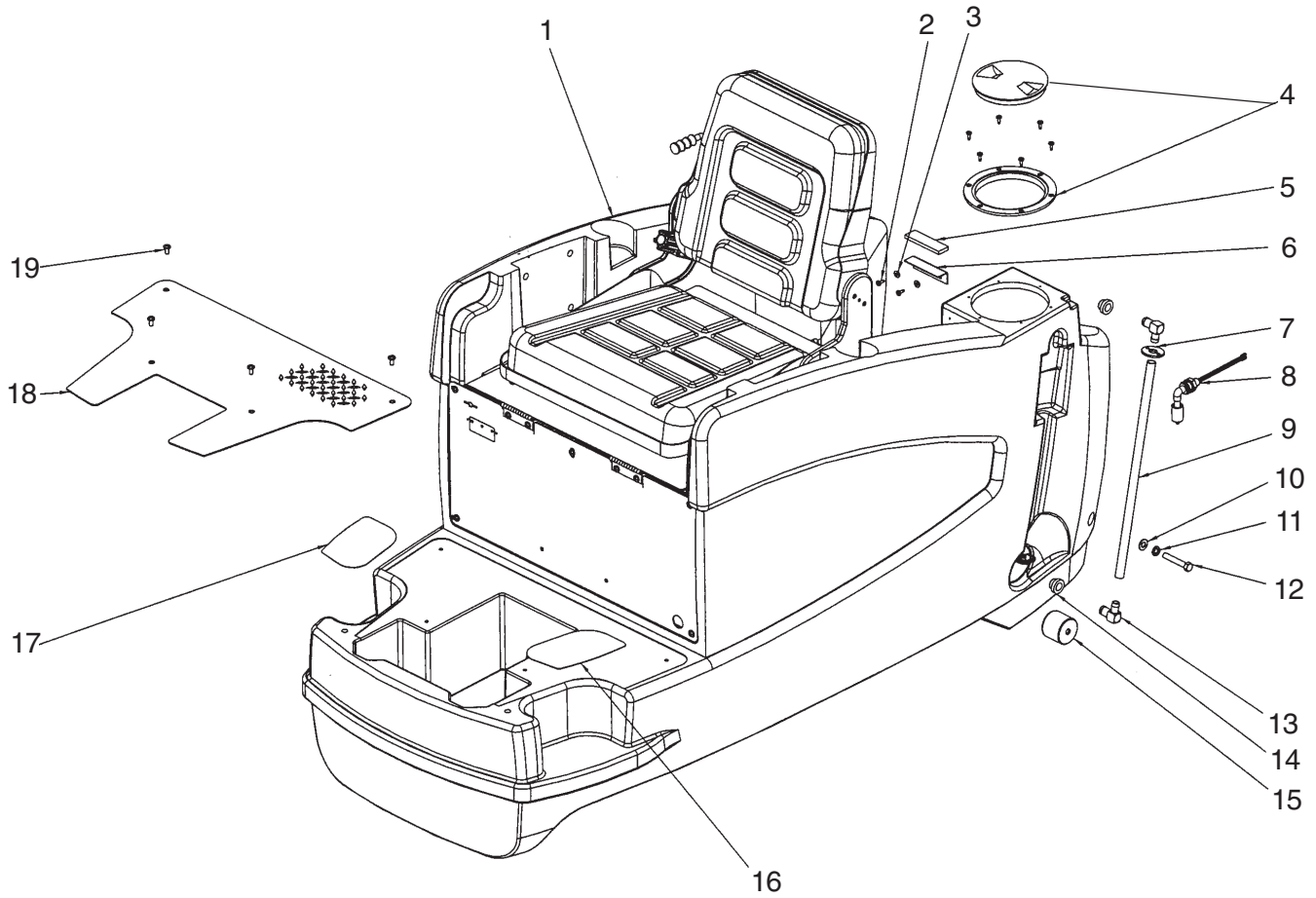



**CLARKE TECHNOLOGY**  
**SCRUBTEC R 571, 586, 571 C, BOOST® R**  
 Solution Tank Assembly Parts List (View 2 of 2) 9/06  
 Drawing # 11099A

<b>Ref</b>	<b>Part No.</b>	<b>Description</b>	<b>Qty</b>
1	30530A	Tank, Solution	1
2	962957	Screw, 10-16 x 1/2 Self Tap	8
3	87036A	Washer, #10 Flat	2
4	30539B	Lid, Solution	1
5	30578A	Gasket, Solution Tank Fill	1
6	61574A	Bracket, Tank Fill Gasket	1
7	61563A	Washer, Sight Tube	1
8	40876A	Sensor, Water Level (Option)	1
9	30564A	Hose, Solution Sight	1
10	980645	Washer, 3/8" S.A.E. Flat	2
11	170883	Washer, Lock 3/8"	2
12	85704A	Screw, 3/8-16 x 2 1/4" Hex	2
13	55189A	Hosebarb, .50 x 90 degree	2
14	31242A	Bushing	2
15	61561A	Pivot, Recovery Tank	2
16	30597A	Pad, Solution Tank Step (Left)	1
17	30596A	Pad, Solution Tank Step (Right)	1
18	61843A	Plate, Deck	1
19	85398A	Screw, 1/4-20 x 1/2" P.H.	4

**CLARKE TECHNOLOGY**  
**SCRUBTEC R 571, 586, 571 C, BOOST® R**  
 Steering Column Assembly Drawing 5/07  
 Drawing # 11087B

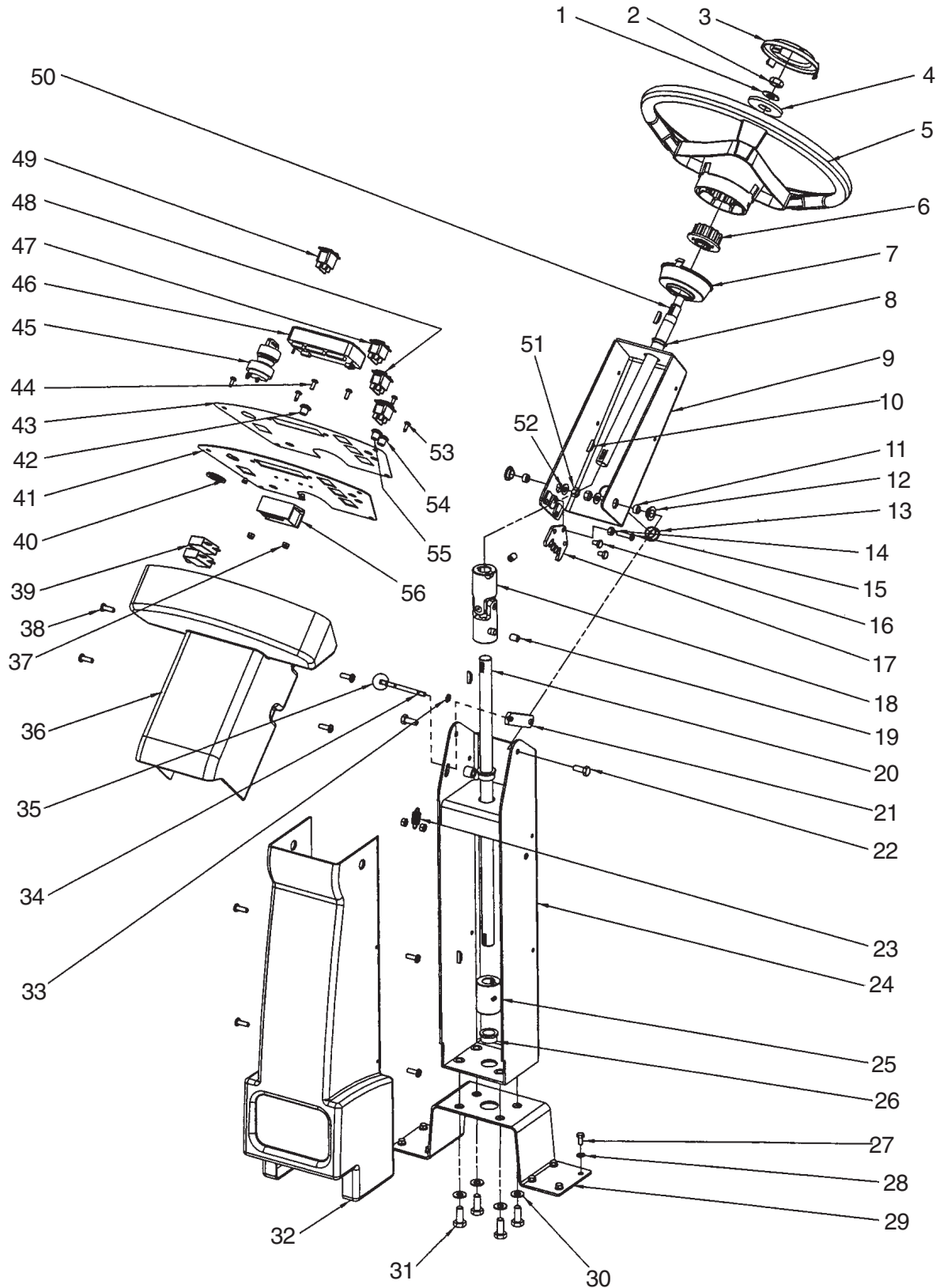

**CLARKE TECHNOLOGY**  
**SCRUBTEC R 571, 586, 571 C, BOOST® R**  
Steering Column Assembly Parts List 5/07  
Drawing # 11087B

Ref	Part No.	Description	Qty
1	980648	Washer, 17/32 x 1 1/16 Plain	1
2	80349A	Nut, 1/2-13 Hex Nyloc	1
3	56497543	Cap, Steering Wheel	1
4	80328A	Washer, Flat	1
5	56497306	Wheel, Steering	1
6	56497560	Adapter, Wheel	1
7	56497308	Cup	1
8	56314148	Bearing, Nyliner	1
9	61848A	Column, Upper Steering	1
10	55400A	Key, 3/16 x 5/32	4
11	56320595	Bushing, .32 x .50 x .28	2
12	56413211	Spacer, Nylon	2
13	56900041	Plug, Cap	1
14	81104A	Nut, 1/4" Nylock	3
15	962495	Screw, 1/4-20 x 1 P.H.	1
16	85742A	Screw, 1/4-20	2
17	56413658	Plate, Column Tilt	1
18	56454081	Universal Joint	1
19	56001958	Screw, 3/8-16 x .25 Set	2
20	61838A	Shaft, Lower (Man. Steer)	1
21	56413661	Handle, Pivot Weldment	1
22	85812A	Screw, M10-1.5 x 30MM	2
23	56305072	Spring	1
24	61839A	Column, Lower Steering	1
25	53759A	Coupling, Sleeve (Man.)	1
26	56250414	Bearing, Flange	2
27	85737A	Screw, 1/4-20 x 1/2 HHCS	8
28	980657	Washer, Lock 1/4	8
29	61837A	Plate, Column Adapter	1
30	980645	Washer, 3/8" SAE Flat	4
31	80088A	Screw, M10-1.5 x 30MM	4
32	30734A	Cover, Front (Lower)	1
33	56003268	Retainer, 1/4" Shaft	1
34	56413664	Handle, Adjustment	1
35	56440817	Knob, Tilt Lock	1
36	30733A	Cover, Front (Upper)	1
37	920722	Nut, 10-32 ESNA	2
38	85387A	Screw, 1/4-16 x 3/4	8
39	41423B	Breaker, 5A Circuit, Cntrl/Act	2
40	40786S	Spacer, Key Switch	1
41	61835A	Panel, Control	1
42	40941A	Horn Button	1
43	71165A	Label, Control Panel	1
44	84237A	Screw, 10-32 x .50 P.H.	2
45	40786A	Switch, CE Key	1
46	40880A	Panel, LCD Control (TRIO)	1
47	40890A	Switch, Maintained Rocker	1
48	40885A	Switch, Momentary Rocker	2
49	40940A	Switch, Maintained Rocker	1
50	56420059	Shaft, Upper Steering	1
51	81112A	Nut, 5/16-18 Thin ESNA	2
52	980651	Washer, 5/16 Flat	2
53	962957	Screw, 10-16 x 1/2 Self Tap	4
54	40748A	Switch, Push Button	1
55	40706A	Switch, Momentary Push	1
56	40879A	Module, Solution Level (Option0)	1

**CLARKE TECHNOLOGY  
SCRUBTEC R 571**

571 Rotary Brush Head Assembly Drawing and Parts List 3/08  
Drawing #10697A

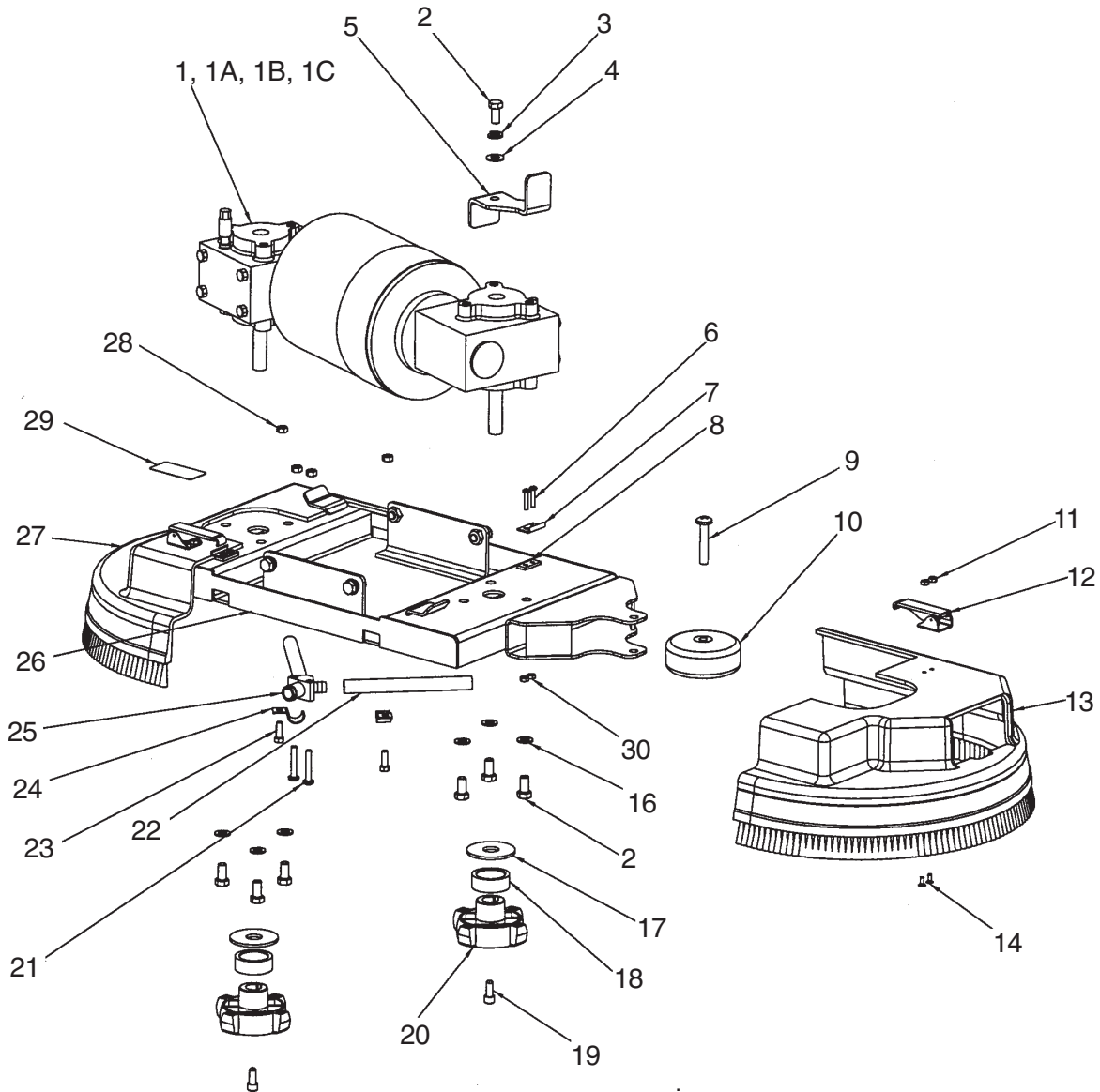

Ref	Part No.	Description	Qty
1	40904B	Motor, Dual Gear Box	1
1A	915102	Key	2
1B	40968A	Carbon Brush/Spring Set (4 of ea.)	1
1C	41048A	Gearbox Asm.	2
2	962244	Bolt, 3/8 - 16 x 3/4 Hex	12
3	170883	Washer, Lock 3/8	2
4	980645	Washer, 3/8 Flat	2
5	61722A	Plate, Auto Side Squeegee	1
	61497A	Plate, Manual Side Squeegee	1
6	85613A	Screw, 8 - 32 x 7/8 PH SS	4
7	55451A	Keeper, Latch	2
8	61570A	Spacer, Keeper	2
9	962803	Screw, 5/16-18 x 1 1/2 FH	1
10	53838A	Wheel, Guide 4"	1
11	920108	Nut, 8 - 32 ESNA SS	4
12	55721A	Latch, Brush Housing	2
13	30535A	Housing, 28" Brush Right Main	1
14	962030	Screw, 8 - 32 x 3/8" FHCS	4

Ref	Part No.	Description	Qty
16	980638	Washer, 3/8 Lock	10
17	59856A	Washer, Rubber	2
18	61658A	Collar, Brush Driver	2
19	962714	Screw, Gimbal Mount	2
20	34400B	Gimbal, Motor	2
21	962989	Screw, 1/4 - 20 x 1 1/2 PH	2
22	34705A	Hose, Solution	2
23	170915	Screw, 1/4 - 20 x 3/4 Hex HD	2
24	782002	Clamp, Manifold	2
25	38014A	Splitter, Solution	1
26	61546A	Frame, 28" Brush Motor	1
27	30536A	Housing, 28" Brush Left Main	1
28	81104A	Nut, 1/4 Nylock	4
29	77091A	Label, Moving Parts	1
30	81109A	Nut, 8-32 ESNA SS	4
NI	30536A	Housing, 28" Left Brush	1
NI	30535A	Housing, 28" Right Brush	1

NI = Not illustrated

NOTE: ♦ indicates a change has been made since the last publication of this manual.

**CLARKE TECHNOLOGY**  
**SCRUBTEC R 586**

586 Rotary Head Assembly Drawing and Parts List 3/08  
Drawing #10698A

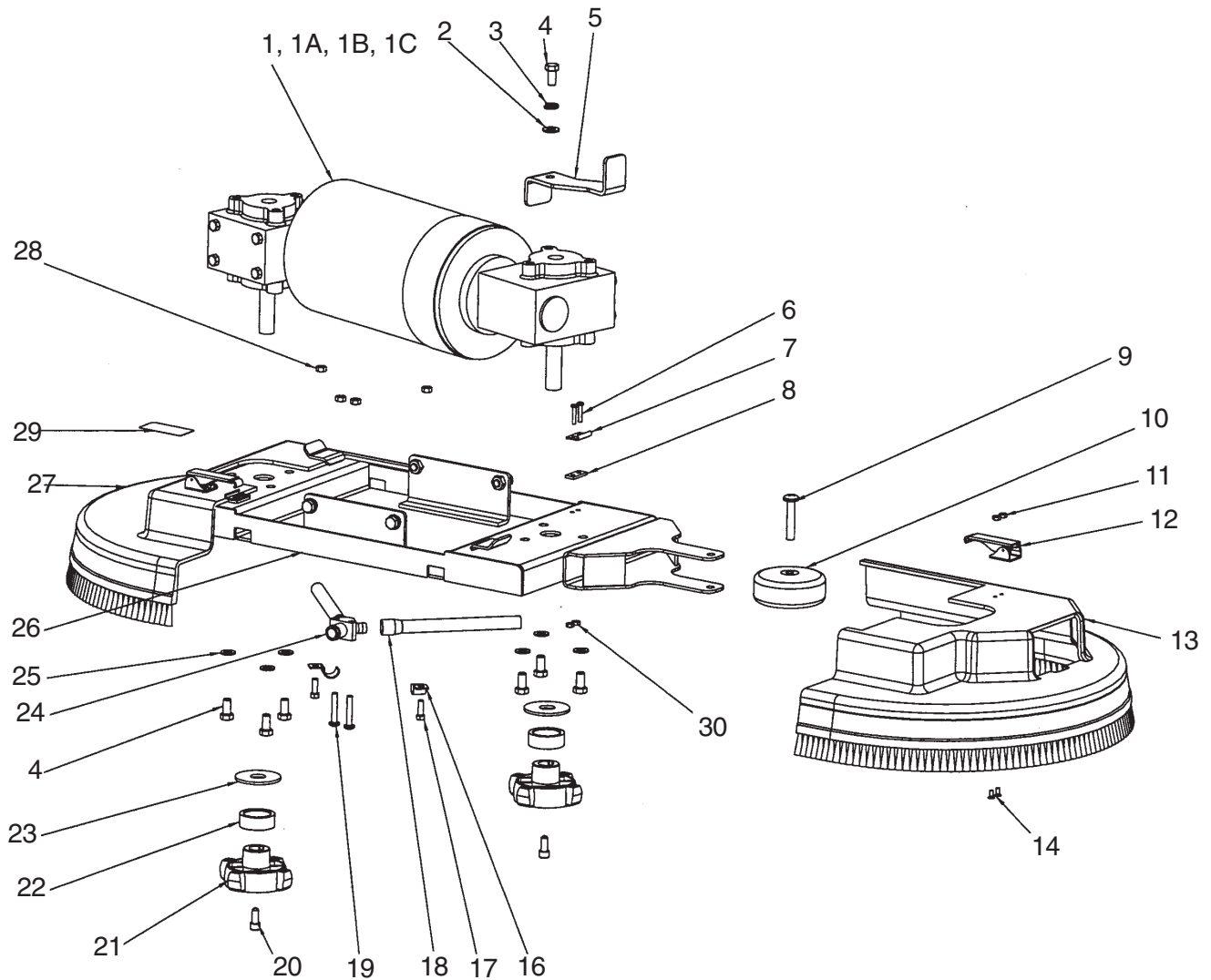

Ref	Part No.	Description	Qty
1	40905B	Motor, Dual Gear Box	1
1A	915102	Key	2
1B	40968A	Carbon Brush/Spring Set (4 of ea.)	1
1C	41048A	Gearbox Asm.	2
2	980645	Washer, 3/8 Flat	2
3	170883	Washer, 3/8 Lock	2
4	962244	Bolt, 3/8 - 16 x 3/4 Hex	11
5	61723A	Plate, Auto Side Squeegee	1
	61497A	Plate, Manual Side Squeegee	1
6	85613A	Screw, 8 - 32 x 7/8 PH SS	4
7	55451A	Keeper, Latch	2
8	61570A	Spacer, Keeper	2
9	962803	Screw, 5/16-18 x 1 1/2 FH	1
10	53838A	Wheel, Guide 4"	1
11	920108	Nut, 8 - 32	4
12	55721A	Latch, Brush Housing	2
13	30537A	Housing, 34" Brush Right Main	1
14	962030	Screw, 8 - 32 x 3/8" FHCS	4

Ref	Part No.	Description	Qty
16	782002	Clamp, Manifold	2
17	170915	Screw, 1/4 - 20 x 3/4 Hex HD	2
18	30210A	Tubing, Vinyl	1
19	962989	Screw, 1/4 - 20 x 1 1/2 PH	2
20	962714	Screw, Gimbal Mount	2
21	34400B	Gimbal, Motor	2
22	61658A	Collar, Brush Driver	2
23	59856A	Washer, Rubber	2
24	38014A	Splitter, Solution	1
25	980638	Washer, 3/8 Lock	10
26	61547B	Frame, 34" Brush Motor	1
27	30538A	Housing, 34" Brush Left Main	1
28	81104A	Nut, 1/4 Nylock	4
29	77091A	Label, Moving Parts	1
30	81109A	Nut, 8-32 ESNA SS	4
NI	30538A	Housing, 34" Left Brush	1
NI	30537A	Housing, 34" Right Brush	1

NI = Not illustrated

NOTE: ♦ indicates a change has been made since the last publication of this manual.

**CLARKETECHNOLOGY**  
**SCRUBTEC R 571 C**  
 571 Cylindrical Head Assembly Drawing 5/05  
 Drawing #10962A

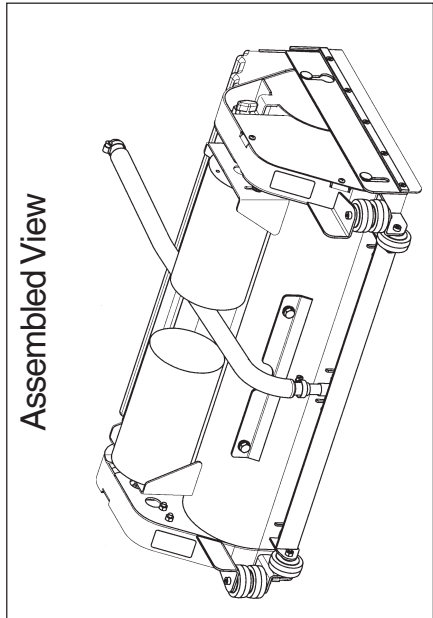
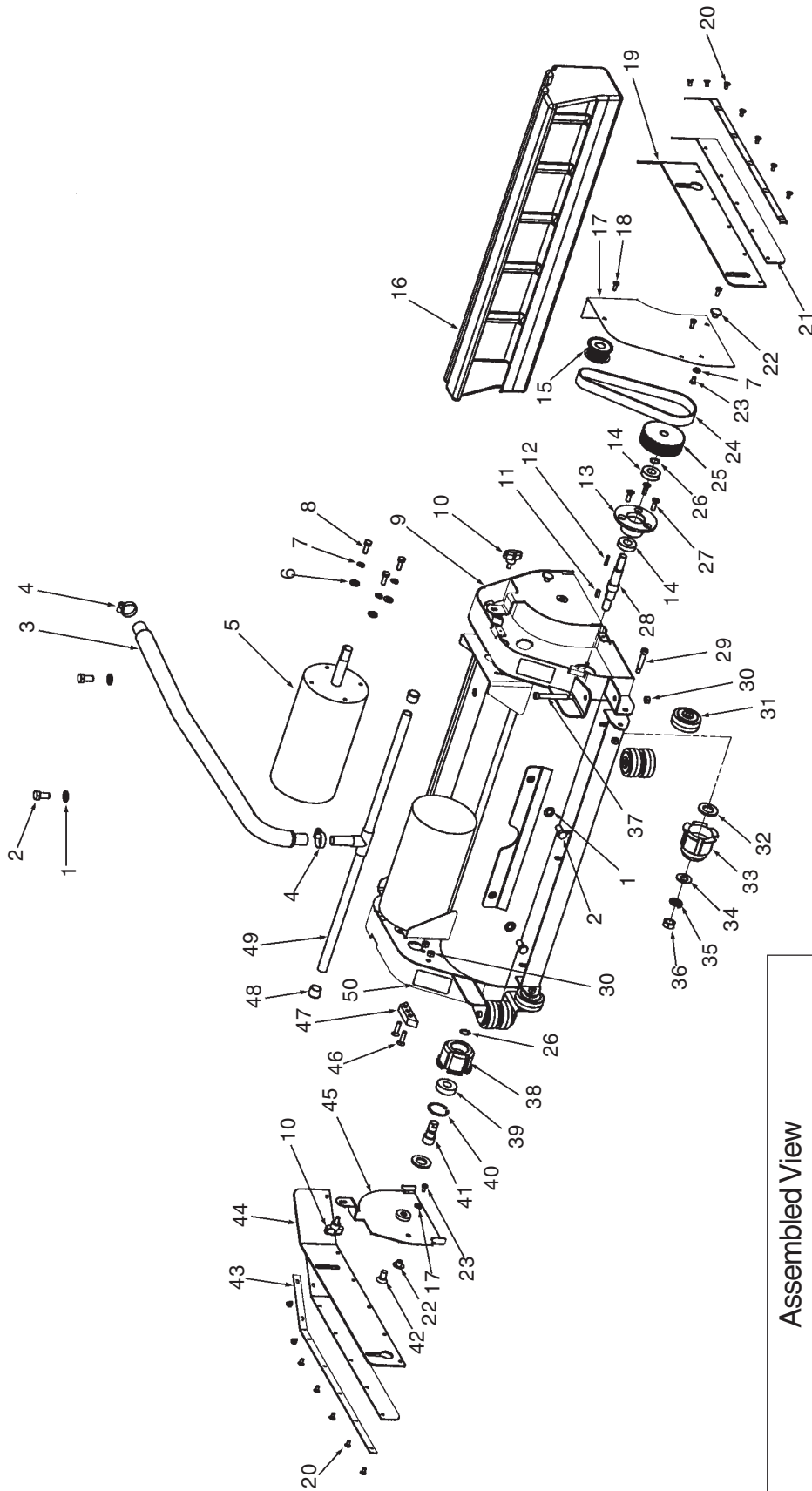

**CLARKETECHNOLOGY**  
**SCRUBTEC R 571 C**

571 Cylindrical Head Assembly Parts List 3/05  
Drawing#10962A

Ref	Part No.	Description	Qty
1	980638	Washer, 3/8 Lock	4
2	962244	Bolt, 3/8-16 x .75 Hex	4
3	30649A	Hose, Solution	1
4	50248A	Clamp, Hose	2
5	40772A	Motor, Brush	2
6	980646	Washer, 1/4" Flat	6
7	980657	Washer, Lock 1/4	9
8	85806A	Screw, 1.4-20 x 3/4 Hex	6
9	61738A	Mainframe, Weldment	1
10	52477A	Knob, 1.4-20 Clamp	2
11	80248A	Key, 3/16 Sq x .50 Lg	2
12	80247A	Key, 1/8 Sq x .75 Lg	2
13	61308A	Bearing Carrier	2
14	51226A	Bearing, Sealed	4
15	61318A	Pulley, Motor	2
16	30618A	Tray, 28" Cyl. Debris	1
17	61743A	Cover, Cyl Head Belt	2
18	84237A	Screw, 10-32 x .50 P.H.	6
19	61752A	Plate, Skirt L.H.	1
20	80240A	Screw, 10-32 x 3/8 F.H.	14
21	30312A	Skirt, Side	2
22	61336A	Spacer, Binding	4
23	962094	Screw, 10-32 x 3/8 R.H.	3
24	53661A	Belt, Drive	2
25	61319A	Pulley, Brush Drive	2
26	467308	Ring, Retainer	4
27	962098	Screw, 1/4-20 x 3/4 F.H.	6
28	61309A	Shaft, Drive	2
29	80270A	Screw, 1/4-20 Shoulder	2
30	81104A	Nut, 1/4" Nylock	8
31	30049B	Wheel, Squeegee 2"	6
32	80257A	Washer, Neoprene	4
33	61293A	Hub, Driver	2
34	980648	Washer, 17/32 x 1 1/16 Plain	2
35	980626	Washer, 1/2 Lock	2
36	170857	Nut, 1/2-13 Hex	2
37	60254A	Bolt, 5/16 x 2.25 Shoulder	2
38	61299A	Hub, Driven	2
39	51225A	Bearing, Sealed	2
40	167312	Ring, Retainer Internal	2
41	61310A	Shaft, Driven	2
42	962973	Screw, 3/8-16 x 3/4 Flat Hd.	2
43	61335A	Retainer, Skirt	2
44	61751A	Plate, Skirt R.H.	1
45	61742A	Door, Brush	1
46	962285	Screw, 1/4-20 x 1.00 F.H.	4
47	61322A	Plate, Brush Door	2
48	53182A	Cap, Plug	2
49	30648A	Tube, Solution Assembly	1
50	77091A	Label, Moving Parts	1

CLARKE TECHNOLOGY  
**SCRUBTEC BOOST® R**  
BOOST® Head Assembly Drawing 10/06  
Drawing #11103A

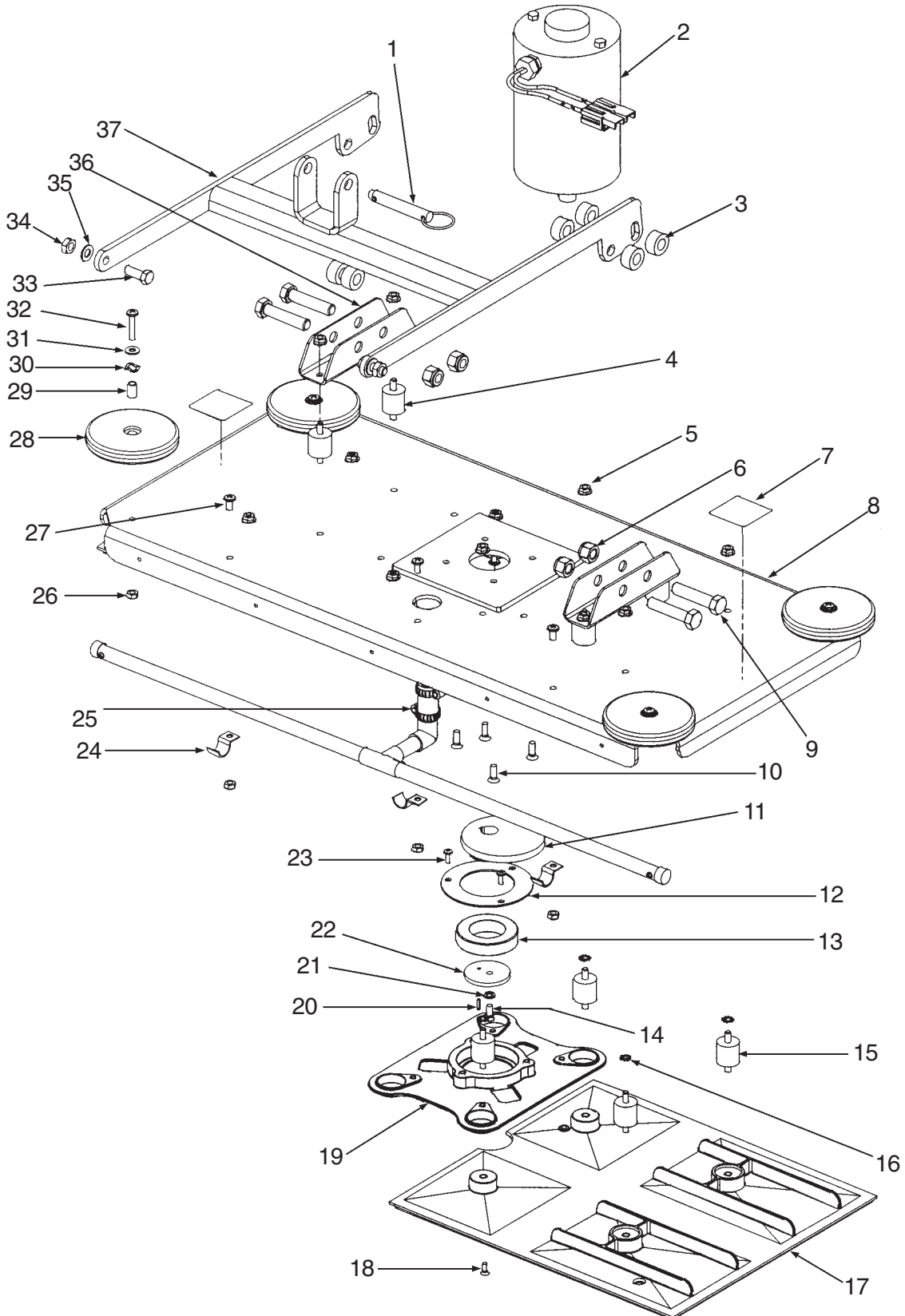



**CLARKE TECHNOLOGY**  
**SCRUBTEC BOOST® R**  
 BOOST® Head Assembly Drawing 6/07  
 Drawing #11103A

Ref	Part No.	Description	Qty
1	53493A	Pin, Quick Release Actuator	1
2	40790B	Motor, 24V DC	1
3	30735A	Spacer, Lift Arm	8
4	11173A	Spring, Rubber	1
5	81220A	Nut, Serrated Flange	12
6	920365	Nut, ½-13 Nylock	4
7	71192A	Label, No Step	2
8	61730B	Plate, Upper 32	1
9	80330A	Screw, ½-13 x 2¼ Gr. 5	4
10	962098	Screw, ¼-20 x ¾ FH	4
11	61753A	Eccentric	1
12	61775A	Retainer, Bearing	1
13	50736A	Bearing	1
14	85737A	Screw, ¼-20 x ½ HHCS	1
15	11172A	Isolator, Deck	1
16	980614	Washer, ¼" Starlock Ext.	8
17	30664A	Plate, Flex Asm. 32"	2
18	84236A	Screw, #10-32 x .50 FH	4
19	30663A	Plate, Driver	1
20	925589	Pin, Roll	1
21	980657	Washer, Lock ¼	1
22	61724A	Retainer, Eccentric	1
23	84237A	Screw, 10-32 x .50 PH	3
24	782002	Clamp, Manifold	3
25	11002A	Tube, Assmebly Drip 32"	1
26	81217A	Nut, ¼-20 Hex ESNA	5
27	85395A	Screw, ¼-20 x ½" PH	3
28	30048A	Wheel, Guide	4
29	61782A	Sleeve, Guide Wheel	4
30	980022	Washer, Wave	4
31	980646	Washer, ¼" Flat	4
32	85301A	Screw, ¼-20 x 1¼ CRPH	4
33	962288	Bolt, 3/8 - 16 x 1 Hex Hd.	2
34	81105A	Nut, 3/8-16 SS ESNA	2
35	87618A	Washer, Flat .39 ID x .75 x 0.62	2
36	61816A	Bracket, Lift	2
37	61818A	Arm, Lift Weldment	1

CLARKE TECHNOLOGY  
**SCRUBTEC R 571, 586, 571 C, BOOST® R**  
Squeegee Assembly Drawing 3/08  
Drawing # 10802A

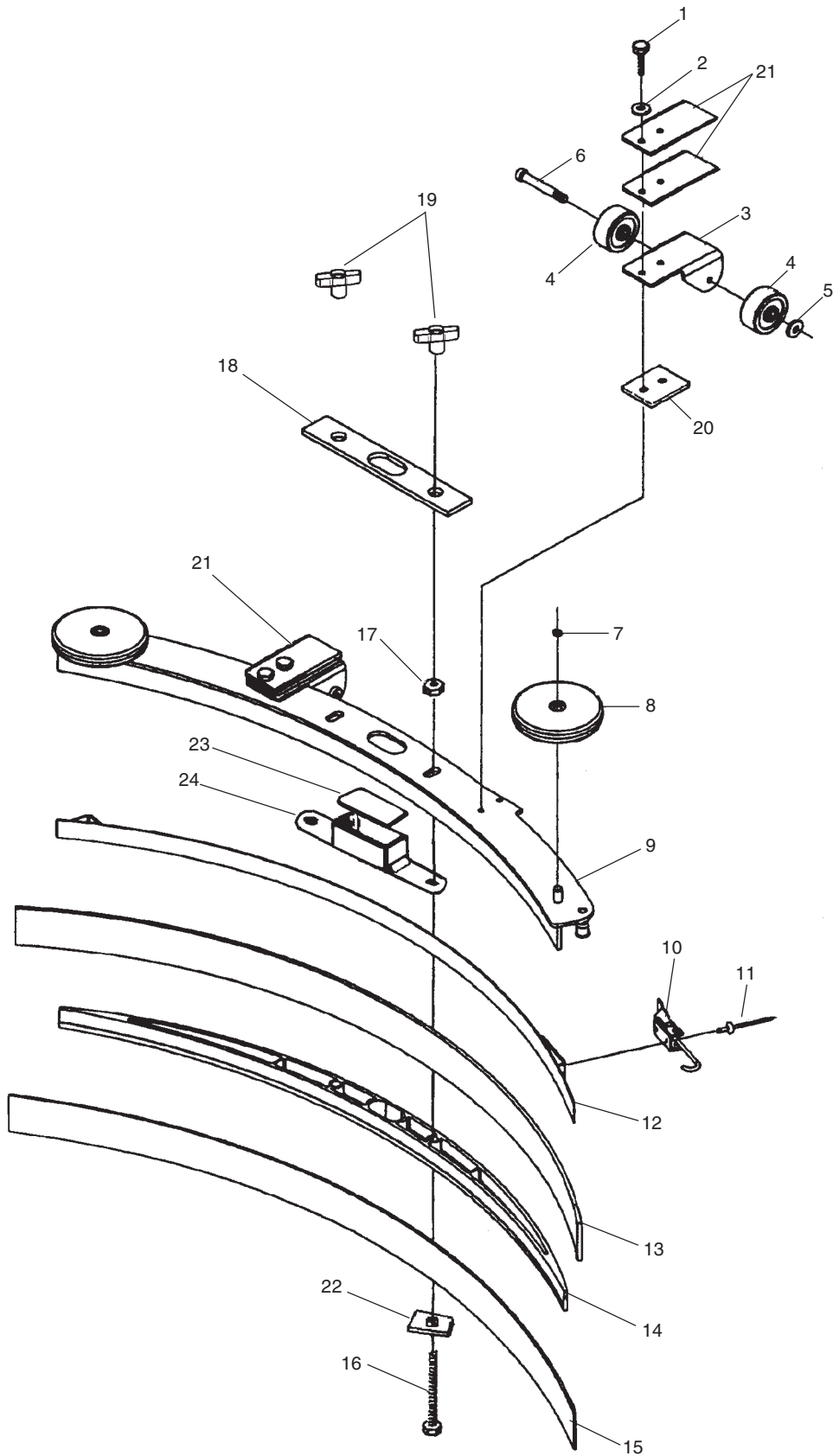

**CLARKETECHNOLOGY**  
**SCRUBTEC R 571, 586, 571 C, BOOST® R**  
 Squeegee Assembly Drawing 3/08  
 Drawing # 10802A, 10803A

Ref. #	Part No.	Description	10068A	10129A	11041L
			99cm Qty	81cm Qty	104cm Qty
1	962720	Screw, ¼-20 x ½ Hex SS	-	4	-
	80253A	Screw, ¼-20 x 1½ Hex SS	4	-	4
2	980657	Washer, ¼ Lock	4	4	4
3	60243A	Bracket, Squeegee Wheel	2	2	2
4	30049B	Wheel, Squeegee	4	4	4
5	81104A	Nut, ¼-20	2	2	2
6	60254A	Bolt, Shoulder 5/16x 2¼	2	2	2
7	53185A	Ring, 3/8 ID Snap	2	2	2
8	30048A	Wheel, Guide, 4 Inch Diameter	2	2	2
9	60272B	Channel, Squeegee Weldment 39"	1	-	-
	60234B	Channel, Squeegee Weldment 32"	-	1	-
	61886A	Channel, Squeegee Weldment 41"	-	-	1
10	50835A	Latch, Squeegee Clamp	1	1	1
11	930086	Rivet, 3/16 x .450 Aluminum	2	2	2
12	60252A	Strap, Clamp, Squeegee Retainer 39"	1	-	-
	60232A	Strap, Clamp, Squeegee Retainer 32"	-	1	-
	61885A	Strap, Clamp, Squeegee Retainer 41"	-	-	1
13	30557A	Blade, Rear, Gum Rubber, 39"	1	-	-
	30717L1	Blade, Rear, Linatex Notched, 39"	1	-	-
	30557L	Blade, Rear, Linatex	1	-	-
	30556A	Blade, Rear, Gum Rubber, 32"	-	1	-
	30556L	Blade, Rear, Linatex	-	1	-
	30774L	Blade, Outer, Linatex, BOOST 41"	-	-	1
14	30058A	Spacer, Squeegee 39"	1	-	-
	30047A	Spacer, Squeegee 32"	-	1	-
	38726A	Spacer, Squeegee 41"	-	-	2
15	30091A	Blade, Front Ribbed 39"	1	-	-
	30066A	Blade, Front Ribbed 32"	-	1	-
	30764L1	Blade, Front Linatex Notched 32"	-	1	-
	30773L2	Blade, Inner Linatex Notched, BOOST 41"	-	-	1
16	80011A	Screw, 3/8-16 x 3	2	2	2
17	81301A	Nut, 3/8-16 Jam SS	2	2	2
18	34260B	Gasket	1	1	1
19◆	25201B	Knob	2	2	2
20	60358A	Shim, Squeegee Wheel	2	2	2
21	61370A	Weight	*	*	*
22	80280A	Nut, Squeegee Backup	2	2	-
23	37016A	Pad, Squeegee Grip	-	-	1
24	62712A	Duct, Squeegee Inlet	-	-	1

\* **Optional - Not supplied with machine.**

NOTE: ◆ indicates a change has been made since the last publication of this manual.

CLARKETECHNOLOGY

**SCRUBTEC R 571, 586**

Front Squeegee Assembly Drawing and Parts List 8/05

(Rotary Machines Only)

Drawing # 10694A

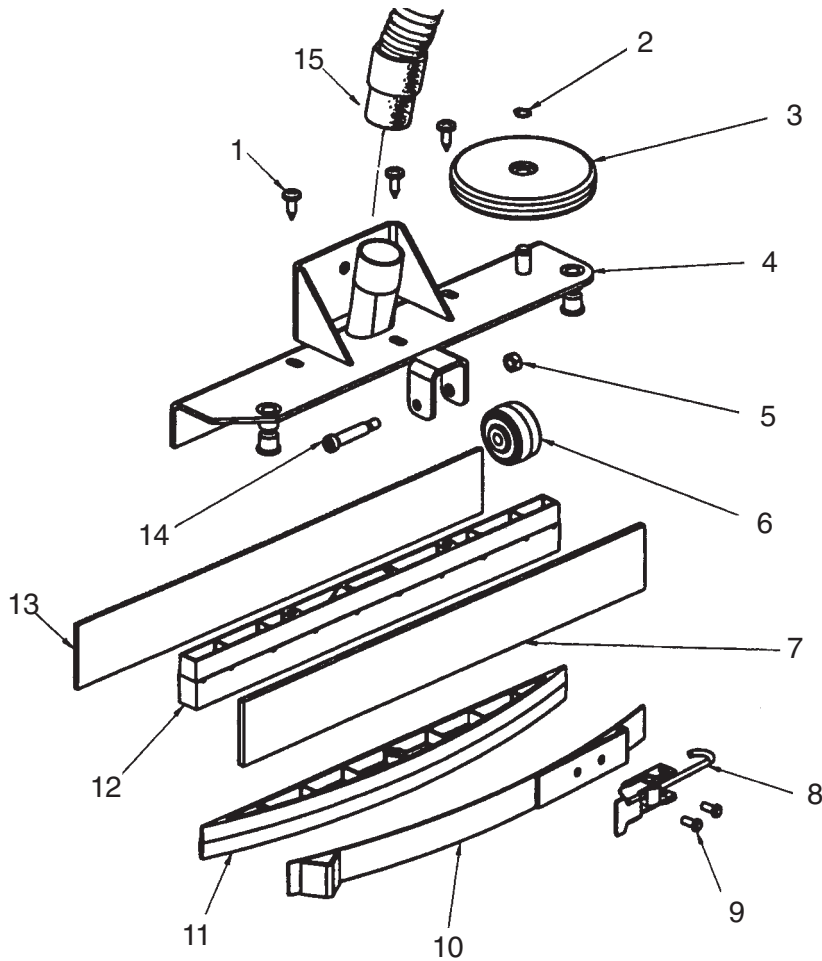

Ref	Part No.	Description	Qty
1	80275A	Screw, 1/4 - 14 x 3/4	3
2	53185A	Ring, Retainer	1
3	30048A	Wheel, Guide	1
4	61496A	Weldment, Fr. Squeegee Base	1
5	81104A	Nut, 1/4 Nylock	1
6	59932A	Wheel, Squeegee 1 5/8	1
7	30540A	Blade, Outer Gum Rubber	1
8	50835A	Latch, Squeegee Clamp	1
9	930086	Rivet, 3/16 x .450 Pan HD	2
10	61495A	Strap, Squeegee Weldment	1
11	53444A	Wedge, Secondary Squeegee	1
12	53443A	Spacer, Secondary Squeegee	1
13	30541A	Blade, Squeegee	1
14	80270A	Screw, 1/4 - 20 Shoulder	1
15	30569A	Hose, Sec. Squeegee	1

**CLARKE TECHNOLOGY**  
**SCRUBTEC R 571, 586**

Front Squeegee Arm Assembly Drawing and Parts List 5/05  
 (Rotary Machine Only)  
 Drawing # 10694A

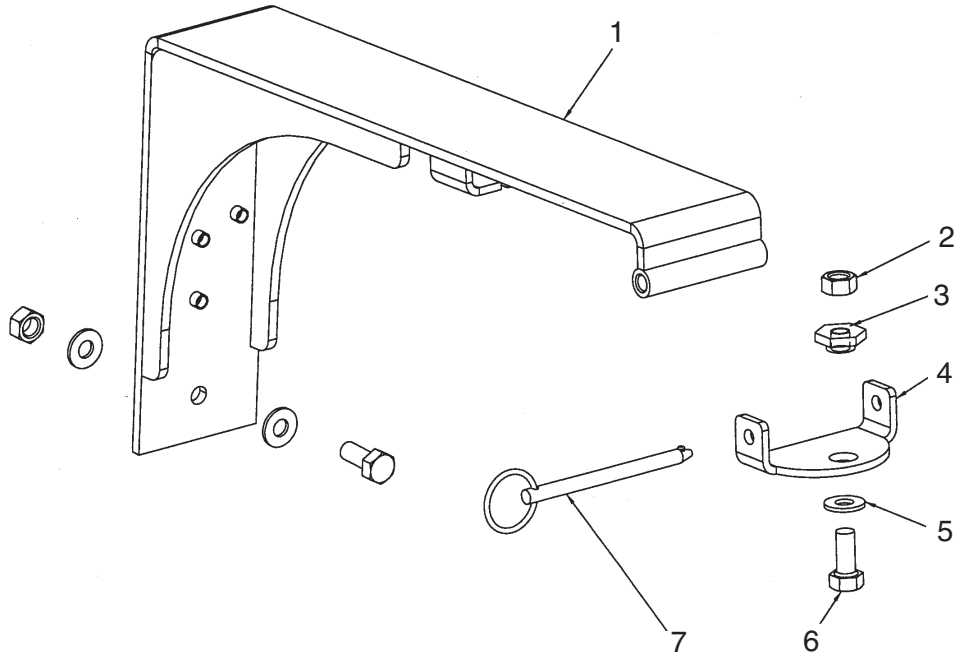

Ref	Part No.	Description	Qty
1	61548A	Arm, Weldment Squeegee	1
2	81112A	Nut, 5/16-18 Thin ESNA	2
3	67867A	Spacer, Squeegee Swivel	1
4	60256A	Arm, Squeegee Pivot	1
5	980651	Washer, 5/16 Flat	3
6	85811A	Screw, 5/16-18 x 3/4 Hex Head	2
7	53491A	Pin, Quick Release	1
NI	61370A	Weight	*

\* Optional - Not supplied with machine.

**CLARKE TECHNOLOGY**  
**SCRUBTEC R 571, 586, 571 C, BOOST® R**  
 Electrical Panel Assembly Drawing and Parts List 3/08  
 Drawing # 11091A, 10782S, 10961S, 10989S

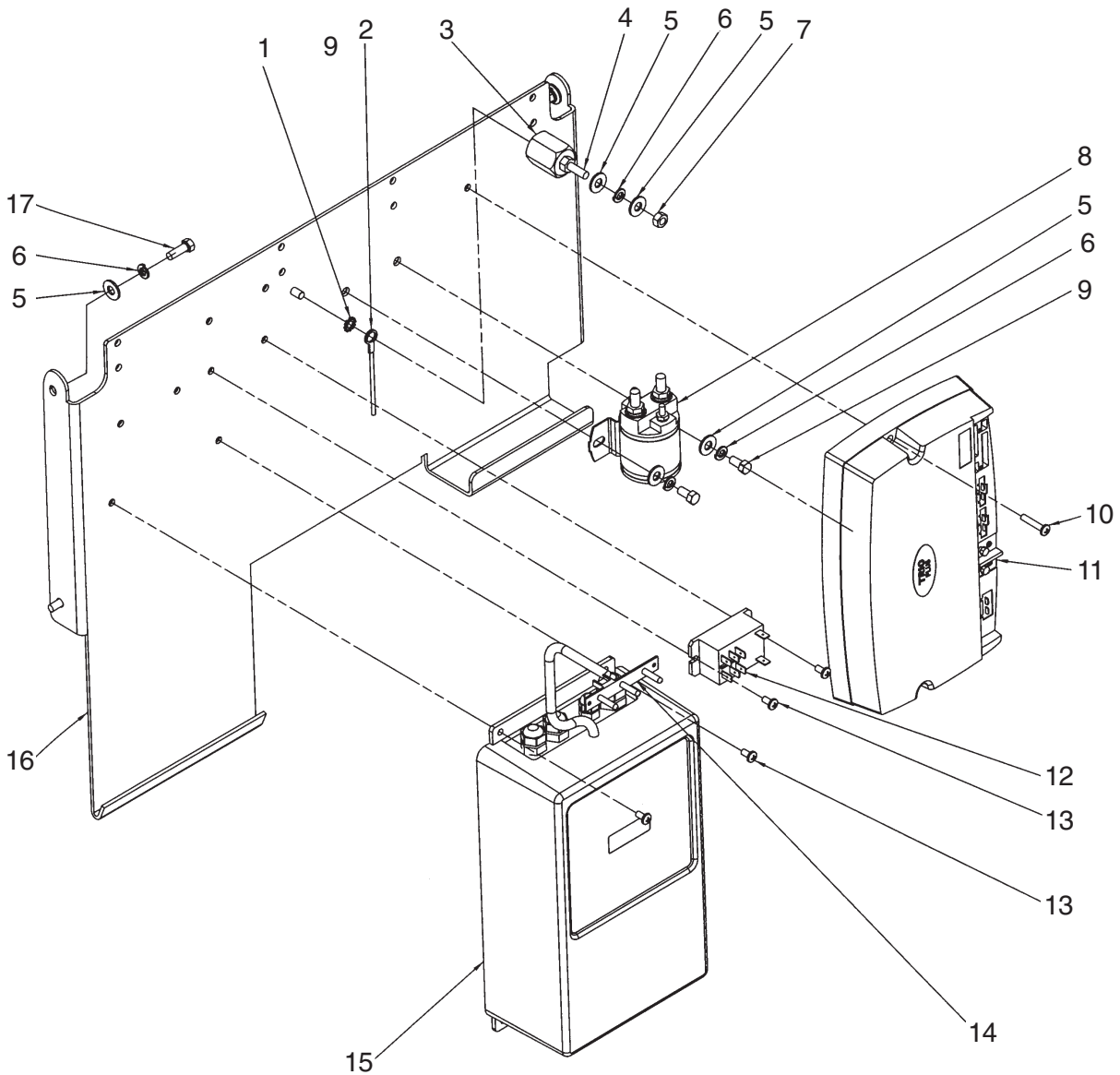

Ref	Part No.	Description	Qty
1	980614	Washer, 1/4" Starlock Ext.	1
2	40932B	Harness, Main Power	1
	40965A	Harness, Main Power (Cyl. only)	1
3	854849	Post, Isolation	1
4	83302A	Stud, 1/4-20	1
5	87026A	Washer, 1/4 Flat SS	8
6	980657	Washer, Lock 1/4	7
7	81104A	Nut, 1/4" Nylock	1
8	41801A	Contactor, Main 36V	1
9	962430	Screw, 1/4-20 x 1/2 HHCS	2
10	962113	Screw, 10-32 x 1.00 P.H.	1
11	53791A	Main Controller, 28" Rotary & Cyl.	1
	53792A	Main Controller, 34" Rotary	1
	53790A	Main Controller, 32" BOOST	1

Ref	Part No.	Description	Qty
12	40892A	Relay	1
13	962929	Screw, 10-32 x 3/8"	4
14	40853A	Display, Battery Charger	1
15	40797A	Charger, 36V Battery w/display	1
16	61558A	Plate, Electrical Panel	1
17	962086	Screw, 1/4-20 x 3/4 Hex Head	4
NI	77092A	Label, Gases and Chemical	1
NI	41217A	Cable, Battery Series	1
NI	40896A	Cable, 32" Neg. Battery	1
NI	40895A	Cable, 24" Pos. Battery	1
NI	40882A	Cable, 200 Amp Fus. Battery	1
NI	40934A	Harness, Logic	1

NI = Not illustrated

NOTE: ♦ indicates a change has been made since the last publication of this manual.



**CLARKE TECHNOLOGY**  
**SCRUBTEC R 571, 586, 571 C, BOOST® R**  
 Electrical Connection Diagram 9/06  
 (pages 63-66)

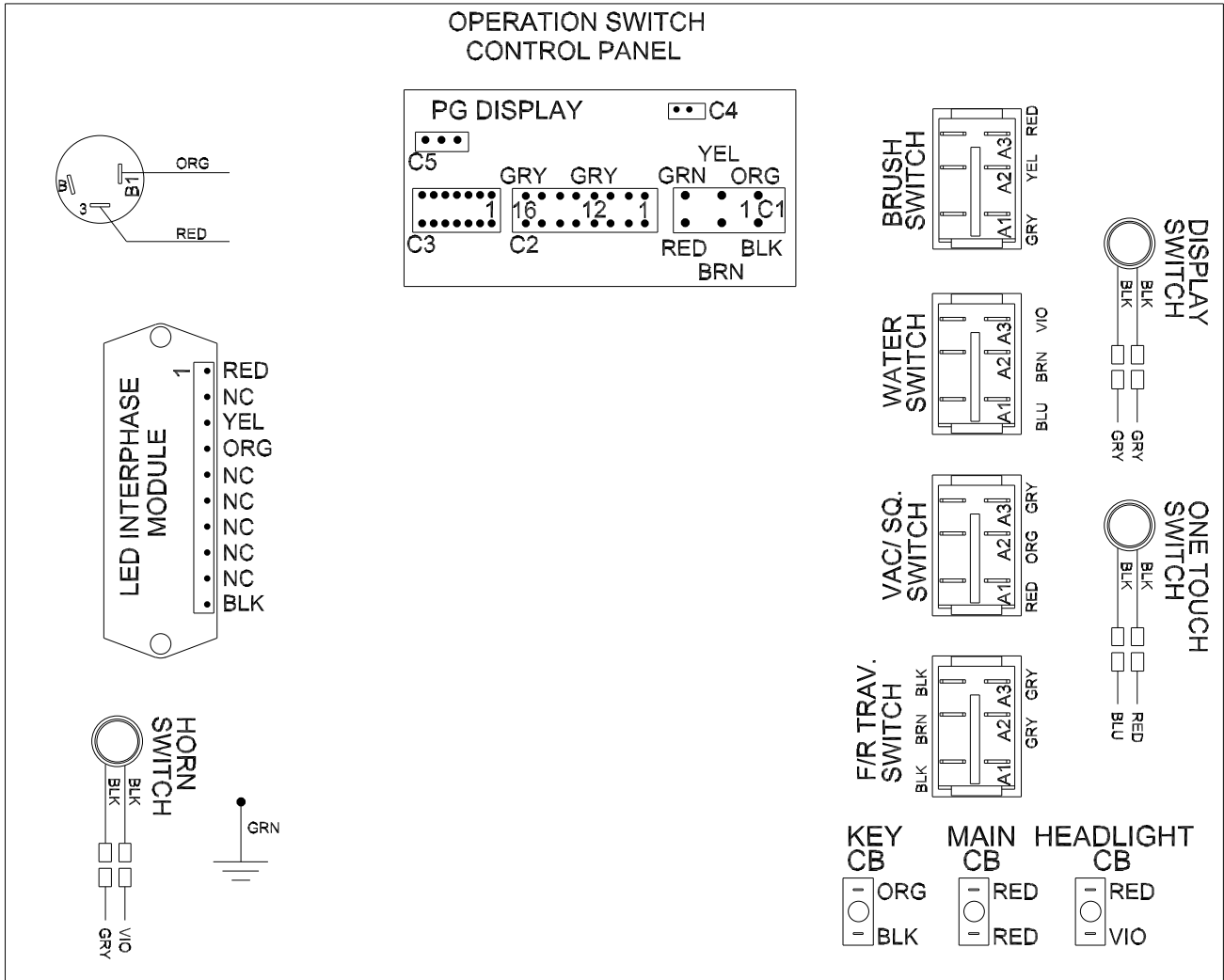



**CLARKE TECHNOLOGY**  
**SCRUBTEC R 571, 586, 571 C, BOOST® R**  
 Electrical Connection Diagram 9/06  
 (pages 63-66)

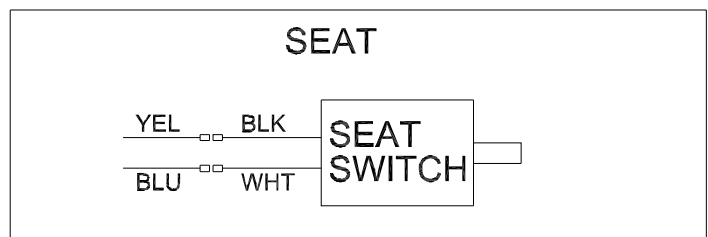
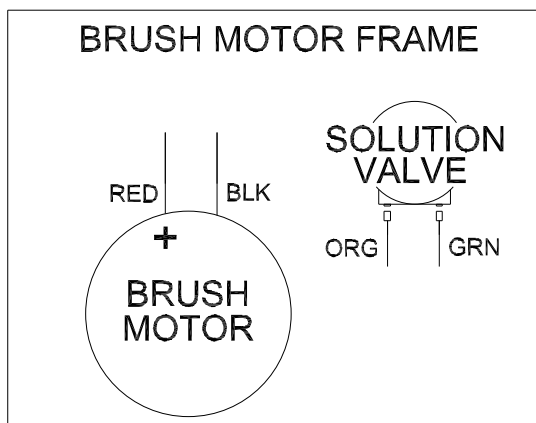
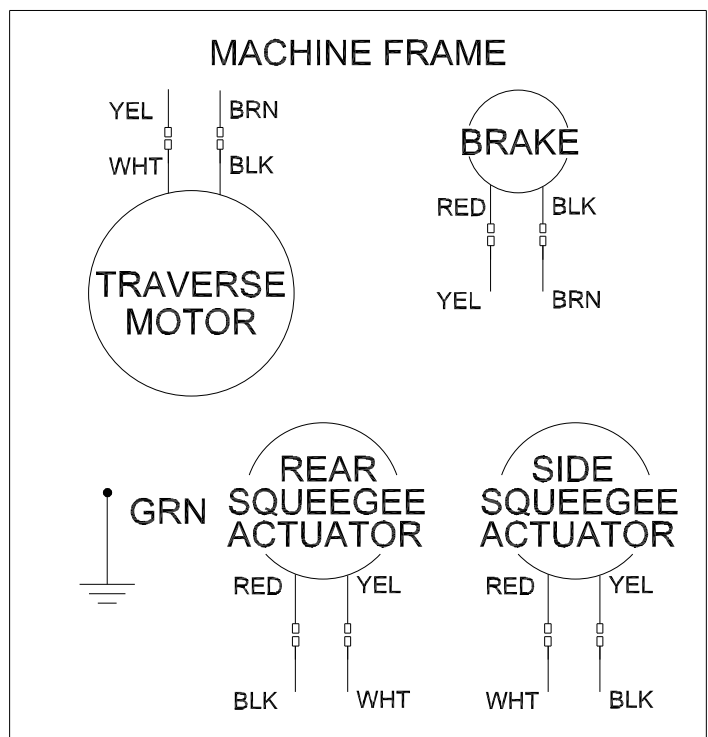
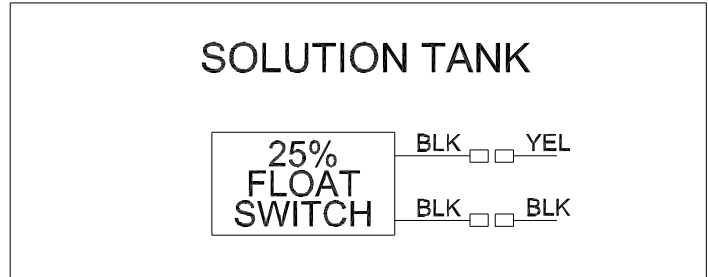
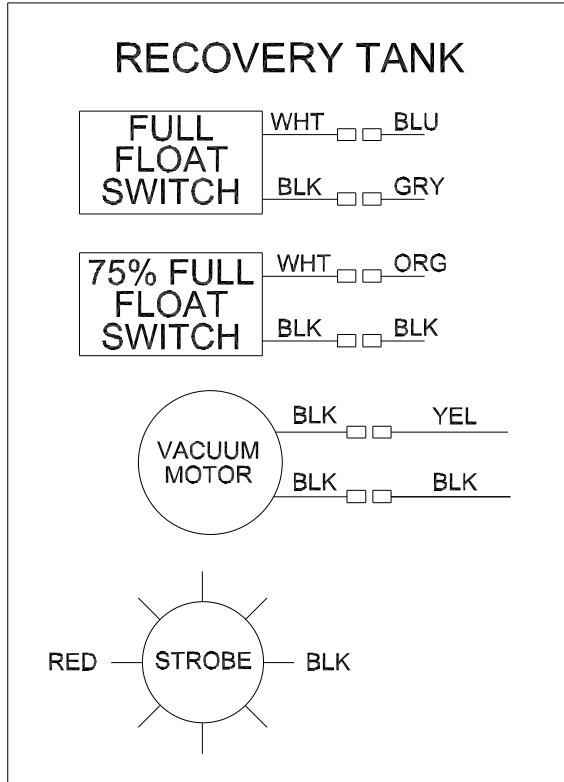

**CLARKETECHNOLOGY**  
**SCRUBTEC R 571, 586, 571 C, BOOST® R**  
 Electrical Connection Diagram 9/06  
 (pages 63-66)

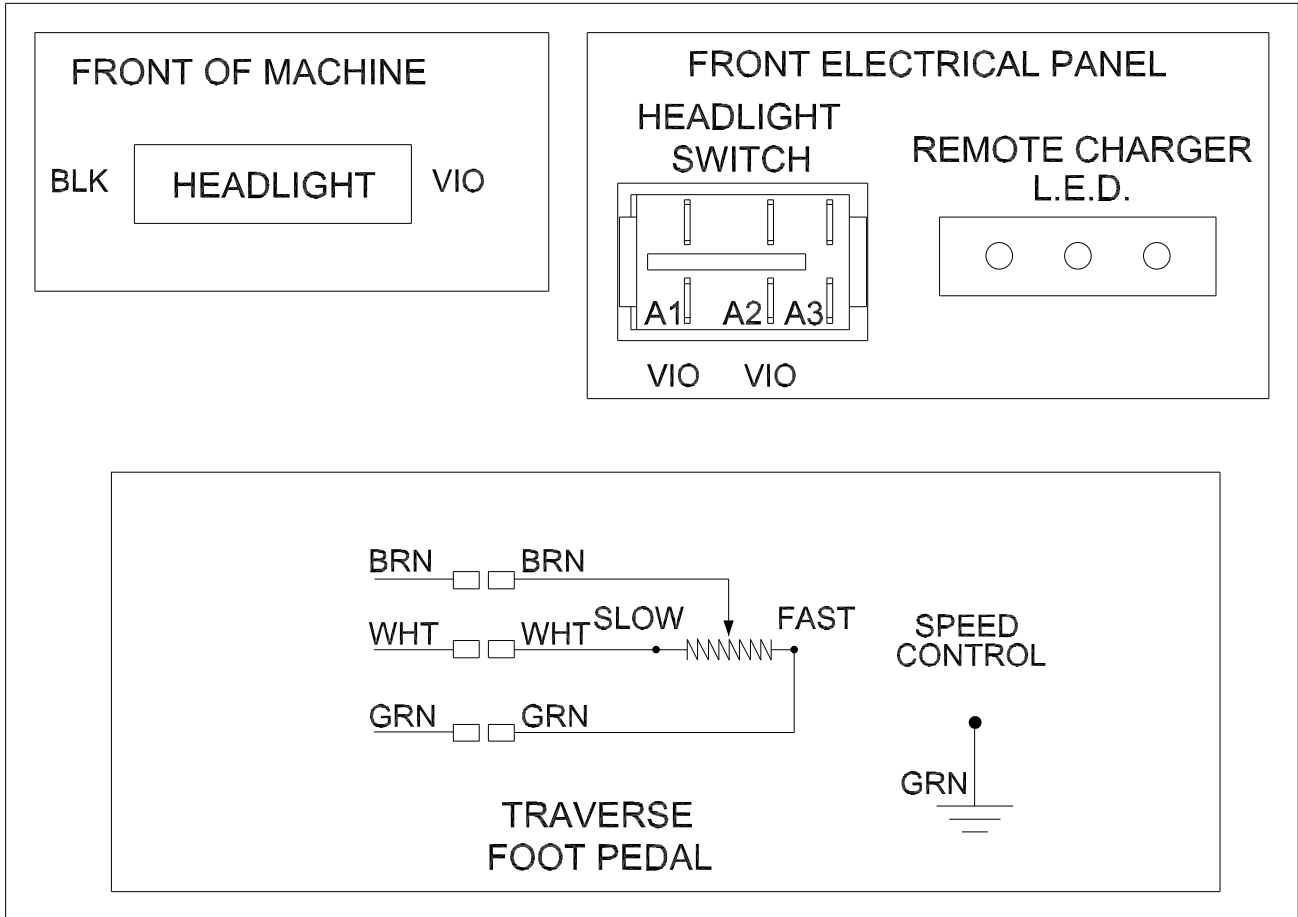



**CLARKETECHNOLOGY**  
**SCRUBTEC R 571, 586, 571 C, BOOST® R**  
 Rider Electrical Options and Ground Connections 9/06

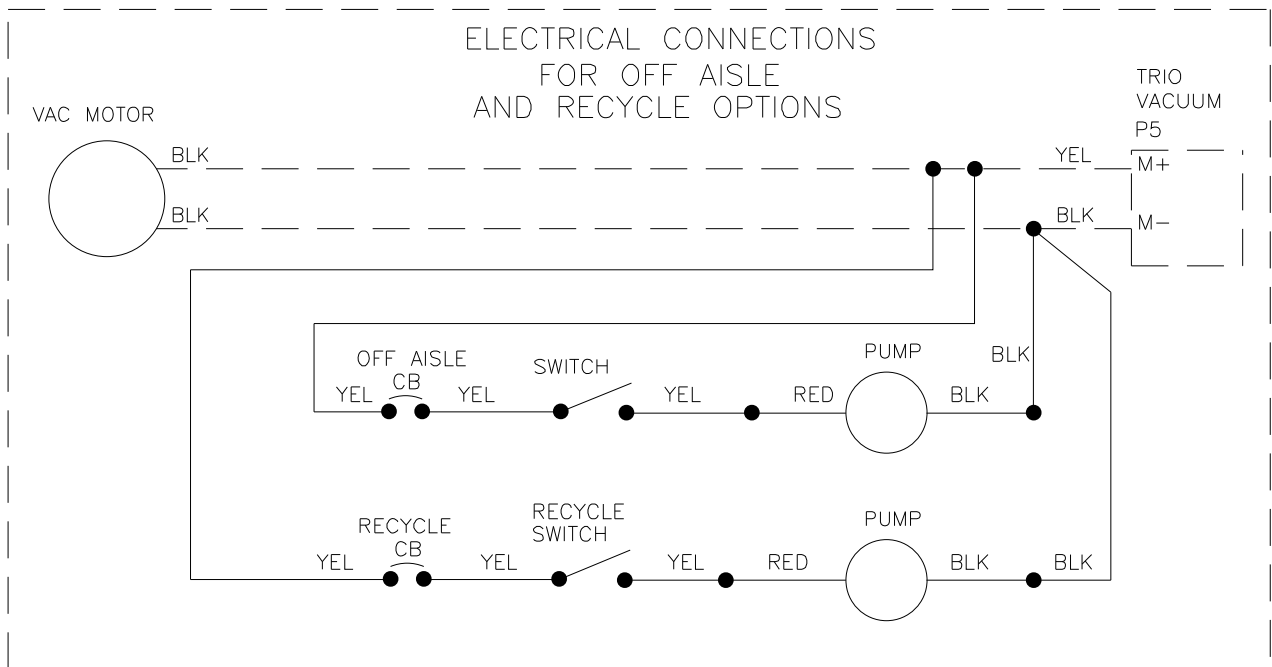
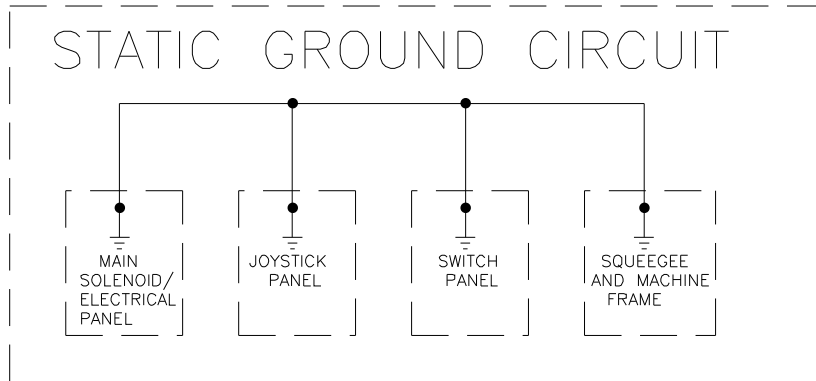





## HEADQUARTERS

### DENMARK

Nilfisk-Advance Group  
Sognevej 25  
2605 Brøndby  
Denmark  
Tel: (+45) 43 23 81 00  
Fax: (+45) 43 43 77 00  
E-mail: mail@nilfisk-advance.dk

## SALES COMPANIES

### AUSTRALIA

Nilfisk-ALTO  
48 Egerton St.  
PO Box 6046  
Silverwater NSW 2128  
Australia  
Tel: (+61) 2 8748 5966  
Fax: (+61) 2 8748 5960

### AUSTRIA

Nilfisk-Advance GmbH  
Nilfisk ALTO  
Metzgerstrasse 68  
A-5101 Bergheim/Salzburg  
Austria  
Tel: (+43) 662 456 400-0  
Fax: (+43) 662 456 400 34  
E-mail: info@nilfisk-alto.at  
www.nilfisk-alto.at

### BELGIUM

Nilfisk-ALTO  
Division of Nilfisk-Advance n.v.-s.a.  
Dornveld/Sphere Business Park  
Industrie Asse 3, nr 11-bus 41  
1731 Zellik-Asse  
Belgium  
Tel: (+32) 02 467 60 50  
Fax: (+32) 02 466 61 50  
E-mail: info.be@nilfisk-alto.com

### CANADA

Clarke Canada  
Part of the Nilfisk-Advance Group  
4080 Sladeview Crescent, Unit 1  
Mississauga, Ontario L5L 5Y5  
Canada  
Tel: (905)569-0266  
Fax: (905) 569-8586

### CZECH REPUBLIC

ALTO Ceska republika s.r.o.  
Zateckých 9  
14000 Praha 4  
Czech Republic  
Tel. (+420) 24 14 08 419  
Fax (+420) 24 14 08 439  
E-mail: info@alto-cz.com

### DENMARK

Nilfisk-ALTO  
Division of Nilfisk-Advance A/S  
Industrivej 1  
9560 Hadsund  
Denmark  
Tel: (+45) 72 18 21 00  
Fax: (+45) 72 18 21 11  
E-mail: salg@nilfisk-alto.dk  
E-mail: service@nilfisk-alto.dk  
www.nilfisk-alto.dk

Nilfisk-ALTO Food Division  
Division of Nilfisk-Advance A/S  
Blytækkervej 2,  
9000 Aalborg  
Denmark  
Tel: (+45) 72 18 21 00  
Fax: (+45) 72 18 20 99  
E-mail: scanio.technology@-  
nilfisk-alto.dk  
www.nilfisk-alto.com

### FRANCE

Nilfisk-ALTO  
ALTO France SA  
Aéroparc 1  
19 rue Icare  
67960 Entzheim  
France  
Tel: (+33) 3 88 28 84 00  
Fax: (+33) 3 88 30 05 00  
E-mail: info@nilfisk-alto-fr  
www.nilfisk-alto.com

### GERMANY

Nilfisk-ALTO  
Division of Nilfisk-Advance AG  
Guido-Oberdorfer-Str. 10  
89287 Bellenberg  
Germany  
Tel: (+49) (0) 180 5 37 37 37  
Fax: (+49) (0) 180 5 37 37 38  
E-mail: info@nilfisk-alto.de  
www.nilfisk-alto.de

### GREECE

Nilfisk-Advance SA  
8, Thoukididou str.  
164 52 Argiroupolis  
Greece  
Tel: (+30) 210 96 33443  
Fax: (+30) 210 96 52187  
E-mail: nilfisk-advance@clean.gr

### HOLLAND

Nilfisk-ALTO  
Division of Nilfisk-Advance BV  
Camerastraat 9  
NL-1322 BB Almere  
Tel: (+31) 36 5460 760  
Fax: (+31) 36 5460 761  
E-mail: info @nilfisk-alto.nl  
www.nilfisk-alto.nl

### HONG KONG

Nilfisk-Advance Ltd.  
2001 HK Worsted Mills Ind'l Bldg.,  
31-39 Wo Tong Tsui St.  
Kwai Chung, Hong Kong  
Tel.: (+852) 2427 5951  
Fax: (+852) 2487 5828

### HUNGARY

Nilfisk-Advance Kereskedelmi Kft.  
II. Rákóczi Ferenc út 10  
2310 Szigetszentmiklos-Lakihegy  
Hungary  
Tel: (+36) 24 475 550  
Fax: (+36) 24 475 551  
E-mail: info@nilfisk-advance.hu  
Sales: erteresites@nilfisk-advance.hu  
Service: service@nilfisk-advance.hu  
www.nilfisk-advance.hu

### ITALY

Nilfisk-ALTO  
Divisione di Nilfisk-Advance A/S  
Localita Novella Terza  
26862 Guardamiglio (LO)  
Italy  
E-mail: d.puglia@nilfisk-advance.it

### JAPAN

Nilfisk-Advance, Inc.  
1-6-6 Kita-shinyokohama, Kouhoku-ku,  
Yokohama, 223-0059 Japan  
Tel.: (+81) 45 548 2571  
Fax: (+81) 45 548 2541

**MALAYSIA**

Nilfisk-Advance Sdn Bhd  
Sd 14, Jalan KIP 11  
Taman Perindustrian KIP  
Sri Damansara  
52200 Kuala Lumpur  
Malaysia  
Tel: (+60) 3 603 6275 3120  
Fax: (+60) 3 603 6274 6318  
E-mail: Densin@tm.net.my

**NORWAY**

ALTO Norge AS  
Bjørnerudveien 24  
1266 Oslo  
Norway  
Tel: (+47) 22 75 17 70  
Fax: (+47) 22 75 17 71  
E-mail: info@nilfisk-alto.no  
www.nilfisk-alto.no

**PEOPLE'S REPUBLIC OF CHINA**

Nilfisk-Advance (Shenzhen) Ltd  
Blok 3, Unit 130, 1001 Honghua Road  
Int. Commercial & Trade Center  
Fuitan Free Trade Zone  
518038 Shenzhen  
P.R. China  
Tel.: (+86) 755 8359 7937  
Fax: (+86) 755 8359 1063

**POLAND**

Nilfisk-Advance Sp. Z.O.O.  
05-800 Pruszków  
ul. 3-go MAJA 8  
Poland  
Tel.: (+48)22 738 37 50  
Fax: (+48) 22 738 37 51  
info@nilfisk-alto.pl  
www.nilfisk-alto.pl

**PORTUGAL**

Nilfisk-ALTO  
Division of Nilfisk-Advance Lda.  
Sintra Business Park  
Zona Industrial Da Abrunheira  
Edificio 1, 1ªA  
P-2710-089 Sintra  
Tel.: (+35) 808 200 537  
Fax: (+35) 121 911 2679  
E-mail: mkt@nilfisk-advance.es  
www.nilfisk-alto.com

**RUSSIA**

Nilfisk-Advance LLC  
127015 Moskow  
Vyatskaya str. 27, bid. 7  
Russia  
Tel: (+7) 495 783 96 02  
Fax: (+7) 495 783 96 03  
E-mail: info@nilfisk-advance.ru

**SINGAPORE**

Nilfisk-Advance Pte. Ltd.  
Nilfisk-ALTO Division  
40 Loyang Drive  
Singapore 508961  
Tel: (+65) 6 759 9100  
Fax: (+65) 6 759 9133  
E-mail: sales@nilfisk-advance.com.sg

**SPAIN**

Nilfisk-ATLO  
Division of Nilfisk-Advance S.A.  
Torre D'Ará  
Paseo del Rengle, 5 Pl. 10  
E-08302 Mataró  
Tel: (+34) 902 200 201  
Fax: (+34) 93 757 8020  
E-mail: mkt@nilfisk-advance.es  
www.-nilfisk-alto.com

**SWEDEN**

ALTO Sverige AB  
Member of Nilfisk-Advance Group  
Aminogatan 18, Box 4029  
S-431 04 Mölndal  
Sweden  
Tel: (+46) 31 706 73 00  
Fax: (+46) 31 706 73 40  
E-mail: info@nilfisk-alto.se  
www.nilfisk-alto.se

**TAIWAN**

Nilfisk-Advance Taiwan Branch  
No. 5, Wan Fang Road  
Taipei  
Taiwan, R.O.C.  
Tel.: (+866) 227 002 268  
Fax: (+886) 227 840 843

**THAILAND**

Nilfisk-Advance Co. Ltd.  
89 Soi Chokechai-Ruammitr  
Viphavadee-Rangsit Road  
Ladyao, Jatuchak, Bangkok 10900  
Thailand  
Tel: (+66) 2 275 5630  
Fax: (+66) 2 691 4079

**TURKEY**

Nilfisk-Advance Professional  
Temizlik  
Ekipmanlari Tic. A.S.  
Necla Cad. NI.: 48  
Yenisahra / Kadiköy  
Istanbul  
Turkey  
Tel.: (+90) 216 470 08 - 60  
Fax: (+90) 216 470 08 - 63  
www.nilfisk-advance.com

**UNITED KINGDOM**

Nilfisk-ALTO  
Division of Nilfisk-Advance Ltd.  
Bowerbank Way  
Gilwilly Industrial Estate  
Penrith Cumbria CA11 9BQ  
Great Britain  
Tel.: (+44) (0) 1768 868995  
Fax: (+44) (0) 1768 864713  
E-mail: sales@nilfisk-alto.co.uk  
www.nilfisk-alto.co.uk

**VIETNAM**

Nilfisk-Advance  
Representative Office  
No. 46 Doc Ngu Str.  
Ba Dinh Dist.  
Hanoi  
SR. Vietnam  
Tel.: (+84) 4 761 5642  
Fax: (+84) 4 761 5643  
E-mail: nilfisk@vnn.vn

**USA**

Clarke  
2100 Highway 265  
Springdale  
Arkansas 72764  
USA  
Tel: (+1) 479 750 8450  
Fax: (+1) 479 756 4540  
E-mail:  
customerservice@clarkeus.com  
www.ClarkeUS.com

Clarke American Sanders  
2100 Highway 265  
Springdale  
Arkansas 72764  
USA  
Tel: (+1) 479 750 1000  
Fax: (+1) 479 750 4540  
E-mail: customerservice  
@americansanders .com  
www.AmericanSanders.com

## CLARKE TECHNOLOGY LIMITED U.S. WARRANTY

This Clarke Technology Industrial/Commercial Product is warranted to be free from defects in materials and workmanship under normal use and service, when operated and maintained in accordance with Clarke Technology's Maintenance and Operations instructions. The warranty period is subject to the conditions stated below.

### **3 YEARS FOR PARTS AND 1 YEAR FOR SERVICE LABOR** (See exceptions below)

Motors must be inspected for carbon motor brush wear at six-month intervals by an authorized Clarke Technology repair station. Failure to comply with the six-month inspection requirement or failure to replace worn motor brushes identified during the inspection will void the warranty on the motors. Cost of the six-month inspection and replacement of carbon motor brushes is the responsibility of the purchaser. In the event of a warranty claim on the motors, proof of inspection and any required motor brush replacement must be provided. This warranty is extended only to the original purchaser for use of the product. It does not cover normal wear parts such as electrical cable, rubber parts, hoses and motor brushes.

### **BATTERY WARRANTY**

In addition to the items above, any original equipment Clarke Technology Battery which becomes unserviceable under normal use within a period of ninety (90) days from date of sale to the original user will be repaired or replaced with one of equal specification at our option, F.O.B. any authorized Clarke Technology Sales or Service Branch, with no charge to the user, except transportation costs. After expiration of the above ninety (90) day period, any battery which fails under normal use will be adjusted to the original user with a new battery of equal specification on an eighteen (18) months pro rate basis from the date of purchase. Adjustment will be determined using the then current list price, plus transportation costs.

Warranty is rendered null and void if battery is not kept filled to the proper level with DISTILLED WATER.

### **CLARKE TECHNOLOGY: POLYDUR® AUTOMATIC SCRUBBER SOLUTION AND RECOVERY TANK EIGHT-YEAR U.S. GUARANTEE**

Your new Clarke Technology machine has polydur Solution and Recovery Tanks. Polydur is a rotationally molded, low-density linear polyethylene that won't crack or dent, and withstands most corrosives and temperature extremes. Clarke Technology backs up your Polydur tanks with an eight-year guarantee. If a tank breaks or leaks under normal use within eight years of the date of purchase, it will be replaced free.

### **CLARKE TECHNOLOGY UNIBODY FRAME FIVE-YEAR U.S. WARRANTY**

Clarke Technology warranties the frame for a period of five years against defects in materials and workmanship under normal use and service.

### **STATED WARRANTIES ARE IN LIEU OF ALL OTHER WARRANTIES, EXPRESSED OR IMPLIED**

Clarke Technology's liability under this warranty is limited to repair of the product and/or replacement of parts and is given to purchaser in lieu of all other remedies, including INCIDENTAL AND CONSEQUENTIAL DAMAGES.

THERE ARE NO EXPRESS WARRANTIES OTHER THAN THOSE SPECIFIED HEREIN. THERE ARE NO WARRANTIES WHICH EXTEND BEYOND THE DESCRIPTION OF THE FACE HEREOF. NO WARRANTIES, INCLUDING BUT NOT LIMITED TO WARRANTY OF MERCHANTABILITY, SHALL BE IMPLIED. A warranty registration card is provided with your Clarke Technology product. Return the card to assist Clarke Technology in providing the performance you expect from your new floor machine.

If a difficulty develops with the product, you should: a) Contact the nearest authorized Clarke Technology repair location or contact the Clarke Technology Service Operations Department, 2100 Highway 265, Springdale, Arkansas 72764, for the nearest authorized Clarke Technology repair location. Only these locations are authorized to make repairs to the product under this warranty. (b) Return the product to the nearest Clarke Technology repair location. Transportation charges to and from the repair location must be prepaid by the purchaser. Clarke Technology will repair the product and/or replace any defective parts with out charge within a reasonable time after receipt of the product.  
ALTO, 2100 Highway 265, Springdale, Arkansas 72764.

**ALTO reserves the right to make changes or improvements to its machine without notice.  
Always use genuine ALTO Parts for repair.**



**2100 Highway 265  
Springdale, Arkansas, 72764**



## Free Manuals Download Website

<http://myh66.com>

<http://usermanuals.us>

<http://www.somanuals.com>

<http://www.4manuals.cc>

<http://www.manual-lib.com>

<http://www.404manual.com>

<http://www.luxmanual.com>

<http://aubethermostatmanual.com>

Golf course search by state

<http://golfingnear.com>

Email search by domain

<http://emailbydomain.com>

Auto manuals search

<http://auto.somanuals.com>

TV manuals search

<http://tv.somanuals.com>