

MGC Manager

User's Guide

VoicePlus Edition, Version 7.5

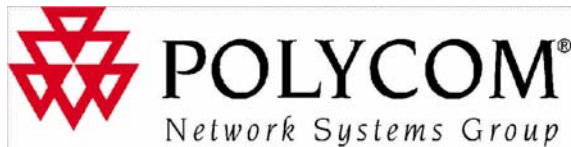

Copyright © 2006 Polycom, Inc.
All Rights Reserved

Catalog No. DOC2066F
Version 7.5

Proprietary and Confidential

The information contained herein is the sole intellectual property of Polycom, Inc. No distribution, reproduction or unauthorized use of these materials is permitted without the expressed written consent of Polycom, Inc. Information contained herein is subject to change without notice and does not represent a commitment of any type on the part of Polycom, Inc. Polycom and Accord are registered trademarks of Polycom, Inc.

Notice

While reasonable effort was made to ensure that the information in this document was complete and accurate at the time of printing, Polycom, Inc., cannot assume responsibility for any errors. Changes and/or corrections to the information contained in this document may be incorporated into future issues.

Canadian Department of Communications (EC) Declaration of Conformity

Polycom Inc., declares that the Polycom VoicePlus with NET-2/4/8 card is in conformity with the following relevant harmonized standards:

EN 60950: 1992 Including Amendments 1,2,3 & 4

EN 55022: 1994

EN 50082: 1997

Complies with the provisions of the Council Directive 1999/EC on radio and telecommunication terminal equipment and the recognition of its conformity.

Notice: The Industry Canada label identifies certified equipment. This certification means that the equipment meets telecommunication network protective, operational and safety requirements as prescribed in the appropriate Terminal Equipment Technical Requirements document(s). The Department does not guarantee the equipment will operate to the user's satisfaction.

Before installing this equipment, users should ensure that it is permissible to be connected to the facilities of the local telecommunications company. The equipment must also be installed using an acceptable method of connection. The customer should be aware that compliance with the above conditions may not prevent degradation of service in some situations.

Repairs to certified equipment malfunctions may give the telecommunications company cause to request the user to disconnect the equipment.

Users should ensure for their own protection that the power utility, telephone lines and internal metallic water pipe system, if present, are properly grounded. This precaution may be particularly important in rural areas.

Caution: Users should not attempt to make such connections themselves, but should contact the appropriate electric inspection authority, or electrician, as appropriate.

Table of Contents

VoicePlus Overview	1-1
About the MGC Manager User's Guide VoicePlus Edition	1-2
VoicePlus Main Features	1-3
System Requirements	1-5
Prerequisites	1-6
VoicePlus Commands Shortcut Keys	1-6
User's Guide Conventions	1-9
Audio Look & Feel	1-11
Audio Only Conferences	1-12
Reservation Templates	1-12
Default Reservation Templates	1-12
Connecting to an On Going Conference	1-16
Dial-in SIP Participants	1-17
Defining Standard Audio Only Conferences and Reservations	2-1
About Conferences	2-1
Conference Scheduling Methods	2-1
Scheduled Conferences	2-1
On Demand Conferencing	2-1
Attended and Unattended Conferences	2-2
Unattended Conference	2-3
Attended Conference	2-3
Conference Types	2-4
IVR and Entry Queue Services	2-5
MCU Configuration and Audio Only Conferences	2-6
Participant Roles	2-7
Participant Connection to Conference	2-8
Participant Connection Types	2-8
Conference Access for Dial-in Participants	2-8
IVR Access	2-12

Conference Access for Dial-out Participants	2-13
Defining New On Going Audio Conferences	2-14
General Properties	2-16
Settings Parameters	2-21
Participants	2-28
Recording	2-35
Completing the Conference Definition	2-36
Resolving Scheduling Conflicts	2-37
Listing On Going Conferences	2-40
Scheduling a New Reservation	2-41
Defining Recurrent Reservations	2-44
Listing Reservations	2-47
End of Conference Reminder	2-48
Defining Participant Properties	2-49
ISDN/PSTN/T1-CAS Participant Definition	2-51
IP (H.323 and SIP) Participant Definition	2-59
Dialing-in from an H.323 Endpoint	2-67
Simple Dial-in Using the IP Card Address	2-67
Simple Dial-in Using the IP Card Alias	2-67
H.323 Advanced Dial-in	2-68
Listing Participants	2-70
Monitoring On Going Conferences	3-1
General Monitoring	3-2
Listing On Going Conferences in the Status Pane	3-3
General Conference and Participant Monitoring	3-5
Monitoring the Conference and Participant Status	3-5
Additional Participant Statuses	3-15
Participant's Audio Status	3-16
Monitor Filter	3-17
Automatic Monitoring of Conferences	3-19
Secure Conference Mode	3-19
Audio Tones	3-21
Noisy Line Detection Mechanism and Automatic Muting	3-22

Participants Queue	3-23
Conference Level Monitoring	3-24
Participant Level Monitoring	3-28
Monitoring ISDN/Telephone Participants	3-29
Checking the Status of VoIP Participants	3-39
Operations Performed During On Going Conferences	4-1
Management Functions Overview	4-2
Participant and Conference Level Operations	4-3
Participant Level Operations	4-5
Making Dial-Out Connections	4-5
Changing Participant Connection Types (Dial-In/Dial-Out)	4-6
Disconnecting Participants from Conferences	4-7
Naming Undefined Dial-in Participants	4-8
Changing the Disconnected Participant's Properties	4-10
Moving a Participant from one Conference to Another	4-11
Designating an Exclusive Speaker	4-12
Changing Participant's Status to Conference Chairperson	4-13
Designating a VIP Participant	4-15
Adjusting Participant's Broadcasting and Listening Volume	4-16
Muting and Unmuting Participant's Audio	4-17
Enabling/Disabling Auto Gain Control (AGC)	4-20
Modifying the Participant's User Defined Properties	4-21
Conference Level Operations	4-22
Adding New Participants to a Conference	4-22
Muting Dial-In Participants Upon Connection	4-28
Adding Remarks During an On Going Conference	4-30
Locking and Unlocking a Conference	4-31
Managing Question-and-Answer Sessions	4-35
Controlling Q&A Queues with the Toolbar	4-35
Adding Questioners to the Q&A Queues	4-36
Changing Participant's Position in Q&A Queue	4-39
Allowing Participant Questions	4-39
Ending Participant Questions	4-40

Removing Participants from the Q&A Queue	4-41
Clearing Q&A Queues	4-41
Managing Voting Sessions	4-42
Conducting a Voting Session	4-43
Viewing and Saving Voting Results	4-47
Placing a Conference On Hold	4-49
Modifying Conference General Parameters	4-52
Changing the Conference Duration	4-53
Ending a Conference before its Scheduled Termination Time ..	4-54
Rescheduling Conference Reservations	4-55
Deleting Recurring Reservations	4-56
Printing Conference Data	4-58
Managing Conferences Using DTMF Codes	4-62
DTMF Guidelines	4-62
Using DTMF Codes in Cascading Conferences	4-68
Modifying Conference and Chairperson Passwords	4-68
Request DTMF Help Menu	4-70
Dialing Out to Invite Participants (Invite Session)	4-70
Chairperson Initiated Blast Dial-out	4-71
Managing Secure Mode Conferences	4-72
Roll Call	4-72
Meeting Rooms and Entry Queues	5-1
Meeting Rooms	5-1
Entry Queues	5-2
Defining a New Audio Only Meeting Room	5-4
Manually Assigning Phone Numbers to the Conference	5-8
Manually Assigning the H.323 Service Prefix to the Conference	5-10
Completing the Meeting Room Definition	5-11
Listing Meeting Rooms	5-11
Defining a New Audio Only Entry Queue	5-13
Enabling Encryption for Entry Queues	5-17
Listing Entry Queues	5-19

Dialing in to an Entry Queue	5-19
IVR and Entry Queue Services	6-1
Conference Access	6-2
Directly	6-2
IVR Queue Access	6-2
Entry Queue Access	6-2
IVR/Entry Queue Stages	6-3
Operations Performed Using IVR Services	6-3
Using Roll Call	6-5
Using SilenceIT	6-6
IVR Requirements	6-8
Hardware	6-8
Audio File Conversion	6-8
Defining IVR Software Module Properties	6-9
Setting IVR Message Services	6-16
Defining a New IVR Message Service	6-16
Listing IVR Message Services	6-36
Setting an IVR Message Service as Default	6-37
Modifying IVR Message Service Properties	6-38
Assigning IVR Services to Conferences	6-39
Defining a New Entry Queue Message Service	6-40
Assigning Entry Queue Services to an Entry Queue	6-47
Connecting to a Conference from an Entry Queue	6-48
Viewing the Audio Messages Status	6-49
Printing IVR/DTMF Codes	6-51
Default IVR Prompts and Messages	6-53
Attended Conferencing	7-1
Requirements for an Attended Conference	7-3
Defining an Operator Conference	7-5
Setting the Participants Connection to the Conference to Attended Mode	7-9
Setting the Entry Queue to Attended Mode	7-9
Setting the Conference Connection to Attended Mode	7-10

Table of Contents

VoicePlus Overview

VoicePlus is the conferencing system of the Polycom MCU that enables Audio Only conferencing. The VoicePlus system includes special features such as the Interactive Voice Response (IVR) functionality, chairperson blast dial-out to multiple pre-defined participants, chairperson and participant DTMF code control of conferences, voting and Question & Answer management, Ad Hoc Auto Cascading, VTX 1000 Resource allocation and more.

Touch-tone commands, MGC Manager and Web controls are the tools that are used to manage both Audio Only conferences and participants and the part of the video bridge that handles Audio Only and IVR functionality in both Audio Only and Video conferencing.

The VoicePlus system uses voice prompts to guide participants to their appropriate conferences. These prompts can be customized to enable multi-lingual support. In Audio Only conference setup, only the functions, operations and icons relevant to this type of conference are displayed in the MGC Manager, while functions and operations relevant to video conferences, such as ATM network connection or video options, are hidden and disabled.

The Polycom VoicePlus conferencing system provides a way to hold meetings with participants at multiple remote sites. It enables end-users to conduct all types of meetings from the office or from the road using a telephone, whether they require a high-level, scheduled, operator-assisted conference or the convenience of on-demand or reservationless meeting.

Audio Only conferences include only Audio participants. In an Audio Only conference, participants can connect to the conference using different network connections: PSTN/ISDN or T1-CAS lines, cellular phones, or VoIP (H.323 or SIP). These conferences allow the use of VoicePlus capabilities.

When the *Audio Look and Feel* mode is set for the MGC Manager, the video parameters are hidden, but you can still monitor video conferences if they are run on any of the connected MCUs.

About the MGC Manager User's Guide VoicePlus Edition

The *VoicePlus Edition* includes information required to set up and monitor On Going Audio Only Conferences, Audio Only reservations, define Audio Only participants and configure the IVR modules. In addition, it includes directions for using the Polycom ReadRecorder audio recording system

If you are new to the Polycom MCU and MGC Manager, we recommend that you read the appropriate Getting Started Guide that accompanies your unit.

The other volumes of the MGC Manager User Guides documentation set describe setting up and monitoring multipoint video conferences and combined audio/video conferencing. They describe performing system configuration activities for the MGC Multipoint Control Units (MCUs) to which it connects. This user's guide provides references to related topics in other volumes of our documentation as relates to each topic.

VoicePlus Main Features

The Polycom VoicePlus conferencing system offers a comprehensive range of capabilities for audio conferencing:

Scheduling methods

Conferences can be started immediately or scheduled in advance on the Polycom MCU by means of the following applications:

- Windows-based MGC Manager
- Browser-based WebCommander
- Microsoft Outlook using the MGC Personal Scheduler add-on
- Polycom *ReadiManager* application

Conference scheduling options

- Ad Hoc conferencing
- On-demand conferencing (On Going)
- “Meet Me” reservationless conferences (Meeting Rooms)
- Scheduled conferences (Reservations)
- Recurrent conferences

Conference modes

- Attended (Operator Assisted) conference; reserved and reservationless
- Unattended conference; reserved and reservationless

Conference access

- VoIP (H.323 and SIP), T1-CAS, and ISDN participants in a single conference
- Dial-in (Toll-free dial-in and caller-paid dial-in)
- Automated (blast) dial-out
- Operator initiated dial-out
- Participant dial-out inviting new participants
- Combination of dial-in and dial-out
- One dial-in number for all conferences (Entry Queue)

Conference features and options

- Automatic password and identification number generation at time of conference booking
- Two allocated passwords: conference and chairperson password

- Single telephone number can be associated with all conferences
- Reservation of resources at the conference setup stage
- User defined fields for additional conference and participant information
- Chairperson features and control
- Presentation (operator guidance)
- Conference locking
- Access to external recording devices
- Use of Roll Call and conference greetings
- Mute-on access (Mute all incoming parties)
- Self Mute
- SilenceIT - automatic muting of noisy lines
- Automatic termination of conference
- Conference On Hold (with background music)
- E-mail notification (with Web scheduling only)
- Access to a Reservations database

Security features

- Conference-specific and Chairperson-specific entry password
- Conference locking mechanism
- Roll Call for joining participants' identification
- Data encryption at MCU, conference and participant level

Conference control options

- Touch-tone (DTMF codes)
- MGC Manager (Windows interface)
- WebCommander (Web Browser)
- Polycom *ReadiManager* application

On Going Conference management and monitoring

- Active or exclusive speaker indication
- DTMF detection for any participant
- Connect and disconnect individual participants
- Add participants during an On Going Conference
- Dial-out to a participant during an On Going Conference (Invite)
- Identify connected participants

- Mute and unmute participants
- Control individual broadcasting and listening audio volume
- Manually and automatically extend the conference duration
- Lock and unlock the conference to dial-in and all other participants
- Move a participant from the main conference to a side area for one-to-one conversation with the Operator
- Terminate the conference before its scheduled end time
- Manage Question-and-Answer queues
- Control voting (polling) sessions
- Configure and enable an audio reminder of impending end of conference, with automatic disconnection at scheduled end of conference
- Secure the conference from unauthorized connection and monitoring
- Operator assistance on demand
- Enhanced operator tools for attended participant conferences
- Monitor conference and participant status
- Monitor all On Going and reserved conferences for multiple MCUs

Application features

- Customizable voice messages
- Configurable new feature event alerts
- Software development kit
- Access and SQL databases can be used to store participant and conference information
- Easily accessible Call Detail Records
- Local or remote operators
- Active display of system resources, individual participant statuses and conference properties
- Recording to an external device

System Requirements

The MGC Manager application can be installed in an environment that meets the following minimum requirements:

- IBM PC compatible computer Pentium II, 400 MHz CPU or higher

- Minimum 64 MB RAM (recommended 128 MB)
- Windows 98[®], Windows ME[®], Windows NT[®], Windows 2000[®] or Windows XP[®] operating system
- Modem (optional)
- Network capabilities - TCP/IP



For detailed information about how to install the MGC Manager application, how to connect to the MGC unit and how to use its main window, menus and toolbar buttons, refer to the MGC Manager User's Guide, Volume I, Chapter 3, "MGC Manager Basics."

Prerequisites

This manual assumes the user has the following knowledge:

- Familiarity with Windows 98[®], Windows NT[®], Windows 2000[®] or Windows XP[®] environment and interface
- Basic knowledge of audio conferencing concepts and terminology
- Familiarity with the Polycom Quick Start Guide for your MCU
- Familiarity with the MGC Manager User's Guide - Volume I, Chapter 3

VoicePlus Commands Shortcut Keys

In MGC Manager, you can quickly accomplish frequently performed tasks by using shortcut keys. For example, pressing <CTRL> + <R> connects or reconnects a participant to an On Going Conference.



- The predefined shortcut keys can be modified using the *Configure Shortcut* function from the *Options* menu. For more details, see the MGC Administrator's Guide, Chapter 5, "Configurable Shortcut Keys" on page 5-144.
- When upgrading the MGC Manager from version 6.0 or earlier, click **Configure Shortcuts** on the *Options* menu, and then click **Restore Defaults** to update the default shortcut keys.

The following default shortcut keys are used in VoicePlus MGC Manager:

Table 1-1: VoicePlus Commands Shortcut Keys

Command	Shortcut Key	Function
<i>New</i>	<Ctrl> + <N>	Used to create a new User Templates file or a new Reservation Templates file.
<i>Open</i>	<Ctrl> + <O>	Opens the User Templates directory or the Reservation Templates directory. Used to view and open the contained files.
<i>Copy/Paste/ Paste As</i>	<Ctrl> + <C> <Ctrl> + <V> <Ctrl> + <P>	Copies the properties of a selected OnGoing conference, Reservation, Entry Queue, Meeting Room or participant, to the clipboard. Note: To select several items to copy/Paste, use the standard Windows conventions. If you want to modify the selected items' name or properties, click <i>Paste As</i> .
<i>Cut</i>	<Ctrl> + <X>	Copies the conference or participant properties to the clipboard while deleting the original item. Used when copying participants from one conference to another.
<i>Delete</i>		Used to terminate a selected On Going Conference, Reservation, participant, operator or template. Opens a dialog box to confirm the selection. Note: To select several items to delete, use the standard Windows conventions.
<i>Save</i>	<Ctrl> + <S>	Saves a User or Reservation Template file, or saves the changes to the database.
<i>Help</i>	<F1>	Opens the relevant Help topic.
<i>Dial-in Dial Out</i>	<Ctrl> + <I> <Ctrl> + <A>	Sets the participant's Connection Type to <i>Dial-in</i> . Sets the participant's Connection Type to <i>Dial out</i>
<i>New Participant</i>	<F8>	Adds a new participant to the On Going Conference, reservation or Meeting Room.

Table 1-1: VoicePlus Commands Shortcut Keys (Continued)

Command	Shortcut Key	Function
<i>Connect Participant/ Disconnect Participant</i>	<Ctrl> + <R> <Ctrl> + <T>	Connects or reconnects a participant to an On Going Conference. Disconnects a participant from the On Going Conference. Note: To select several participants, use the standard Windows conventions.
<i>Mute Audio/ UnMute Audio</i>	<Ctrl> + <M> <Ctrl> + <U>	Mutes the participant's audio channel. Unmutes the participant's audio channel.
<i>Refresh Database</i>	<F9>	Refreshes the database.
<i>Next Questioner</i>	<Alt> + <N>	During a Q&A session, allows the operator to let the next participant in the Q&A queue ask the question.
<i>Paste Entry Queue As</i>	<Ctrl> + <E>	Used to modify Entry Queue properties or name when pasting the selected entry queue from the clipboard to the <i>Meeting Rooms & Entry Queues</i> list. Opens the <i>Entry Queue Properties</i> dialog box.
<i>Attend</i>	<F2>	Moves the participant to the Operator Conference for assistance.
<i>To Home Conference</i>	<F3>	Moves the participant from the Operator to the destination (Home) conference.
<i>Hold</i>	<F4>	Enables the operator to place the attended participant on hold.
<i>Clear Q&A Queue</i>	<Alt> + <C>	Clears the selected participants listed in the Q&A queue.
<i>Move (in attended queue dialog)</i>	<F5>	Enables the operator to move the attended participant to a selected conference (<i>Attended Participant</i> dialog box).
<i>Next (in attended queue dialog)</i>	<F6>	Enables the operator to attend to the next participant in line (<i>Attended Participant</i> dialog box).

Table 1-1: VoicePlus Commands Shortcut Keys (Continued)

Command	Shortcut Key	Function
<i>Join to Conference</i>	<F10>	Enables the operator to temporarily join an On Going Conference, for example for short announcements or assistance.
<i>End Join Operation</i>	<F11>	Enables the operator to return to the Operator Conference.
<i>Attend Next Party</i>	<F12>	Moves the next participant in line from the Participants Queue to the Operator Conference, for assistance.
<i>Context Help</i>	<Shift> + <F1>	Opens the relevant Help topic.

User's Guide Conventions

The following terms and conventions are used in this Guide:

- “Open” or “Double-click” is used to open files and applications. “Double-click” can also expand a tree or open a dialog box.
- “Select” or “Click” is used to highlight a part of the window, dialog box or menu that you want to be changed with your next action. “Click” can also select a menu option or activate a toolbar button.
- “Right-click” is used when you press and release the right mouse button to open a pop-up menu.
- “Click **OK**” means that you can either click the OK button with the mouse, or press the <Enter> key on the keyboard.
- Keyboard keys appear in capital letters, between these two symbols < >. For example, the Shift key appears as <Shift>.
- The plus sign (+) between two key names indicates that you must press and hold down one key while pressing down the second key. For example, “press <Alt> + <P>” means that you press and hold down the Alt key while you press the P key.
- **Bold** type indicates the word or the character that you should type into a text box or the name of the menu or command that you should select.
- *Italic* type indicates the name of a menu, a dialog box or a field to or from which to select or enter an option.

- “Expand a tree” means to click on the plus sign (+) next to it or double-click the icon to display the dependent branches.
- Tips and notes are indicated by an icon and appear in a special format on a gray background. For example:



This is an example of the type of note that you encounter in this User Guide.

Audio Look & Feel

The MGC Manager application that is used for Audio Only conferencing can be set to the **Audio Look & Feel** mode to hide all video associated functions and display only Audio Only parameters.

To set the MGC Manager to Audio Look & Feel:

1. On the *Options* menu, click **Audio Look & Feel**.

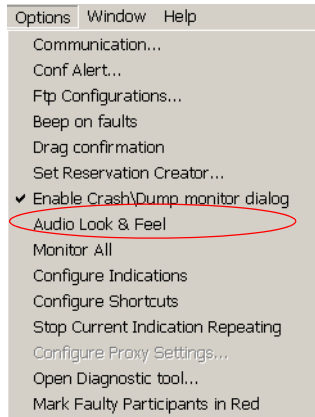

A check mark appears next to **Audio Look & Feel**, indicating that this mode is active. All video related functions and dialog boxes are hidden.

2. Click this feature again to cancel the Audio Look & Feel mode.
3. Restart the MGC Manager application.

Audio Only Conferences

The MGC Manager provides various methods to set up and schedule conferences. Each method is represented in the MCU tree by a name and an icon.

After the scheduling method is determined, you must select a conference type, and determine how the participants connect to the conference.

Participants can connect to the conference by an accessing method such as Entry Queue, conference IVR Queue, or directly and by the conferencing service level, i.e. operator attended or unattended conferencing.

When user's move from one conference to another, they maintain the resources as allocated to them. A VTX 1000 user who moves from a VTX enabled conference to a VTX disabled conference is able to move back to the VTX enabled conference and maintain the wide band connection as initially allocated.

Reservation Templates

A Reservation template contains a partial or complete definition of a single conference. It is used to run a series of conferences that use the same parameters, such as participants, transmission rate and phone connections.

You can use a Reservation template to schedule a conference to start immediately (On Going Conference), or to start automatically at a predefined date and time (Reservation).

For information on defining a reservation template, see the MGC Manager User's Guide Volume II, Chapter 7.

Default Reservation Templates

Five default Reservation templates are installed with the MGC Manager:

- **Default-Audio:** is the only Reservation template designed for Audio Only conferencing. It includes the default IVR Service.

When you first start the MGC Manager application, the *Reservations in Database* window automatically opens listing the Default group in the Root tree.

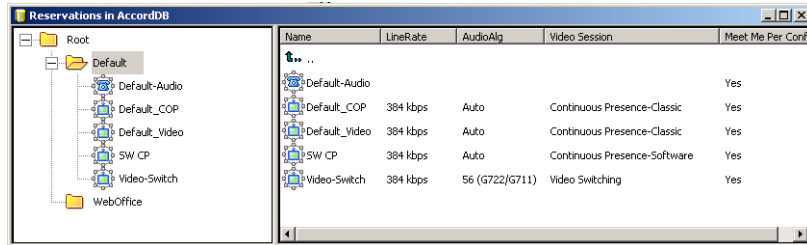

Figure 1-1: Reservations in Database Window



You can push or drag the Main window sizing handle to resize the window and display the Reservations in Database window beside or beneath the Main window.

The MGC Manager automatically displays the *Reservations in Database* window when starting the MGC Manager application every time the application opens, unless you close *Reservations Database* window. If you close it, it will not automatically reopen unless you manually open it and leave it open. You can access the *Reservations Database* window by clicking **Reservations in AccordDB** from the *Window* menu.

Using the default Reservation templates, you can schedule a conference to start immediately (On Going Conference), or to start automatically at a predefined date and time (Reservation).

To start an On Going Conference from a default Reservation template:

1. Display the *Reservations Database* window.

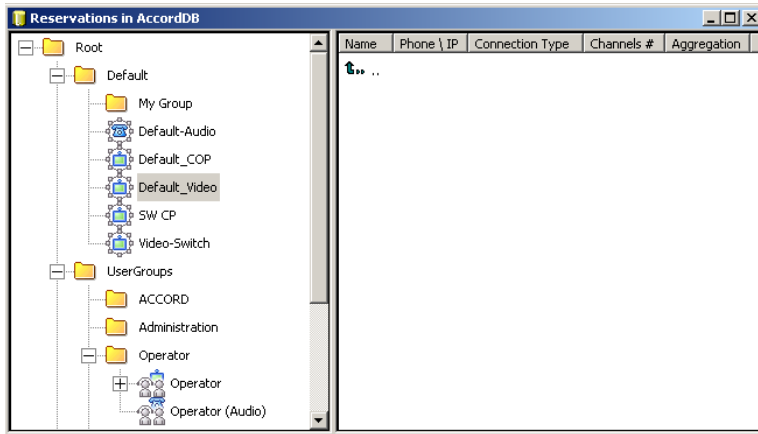

- a. If the *Reservations Database* window is closed, open it. For a detailed description of the *Reservations Database* window, see the MGC Manager User's Guide, Volume I, Chapter 3, "Default Reservation Templates".
- b. If the *Reservations in Database* window is hidden behind other windows, display it on top of the MGC Manager Main window: On the Window menu, click **Reservations in <database name>**.

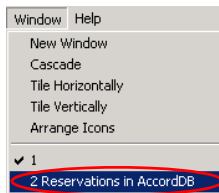

2. Expand the Default templates tree until you locate the desired Reservation template.

- To start an On Going Audio Only Conference, right-click the icon of the *Default-Audio* template and then click **Start Immediately**.

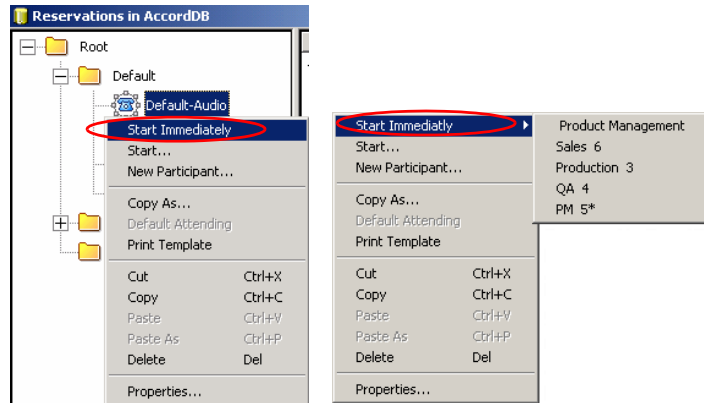

- If you are connected to more than one MCU, an arrow appears next to *Start Immediately* option. Click the arrow to display the list of MCUs and then click the name of the MCU to use for running the conference.
- Alternatively, click **Start** to schedule a conference to start now, while modifying its properties (such as name, duration or passwords) or to schedule the conference to start later (*Reservations*).

The conference is started and is added to the On Going Conference list. If you have scheduled the conference to start later, it will appear in the *Reservations* list.



If the MCU does not have enough resources to run the conference, an appropriate error message is displayed.

Connecting to an On Going Conference

You can add dial-out participants to the conference either by selecting the participants from the Participant database, from a User Template file or by defining them directly during the On Going Conference. For a discussion on adding participants directly to the conference, see Chapter 4, “Adding New Participants to a Conference” on page 4-22.

Dial-in participants can connect directly to the conference using its dial-in number (PSTN/ISDN/T1-CAS participants) dialing string composed of the IP Network Service Prefix and conference Numeric ID (H.323 participant) or the conference URI (SIP participant).

Undefined participants connect to a conference by using the conference dial-in number (ISDN/T1-CAS/PSTN), dialing string (H.323) or SIP URI (SIP).

The ISDN/T1-CAS dial-in number, the H.323 Network Service Prefix and conference numeric ID are displayed in the *Status* pane of the MGC Manager main window.

To view the list of On Going Conferences and their dial-in numbers:

- Expand the *MCU* tree, and then click the *On Going Conferences* icon. The list of On Going Conferences with their H.323 Network Service Prefixes, Numeric IDs and dial-in numbers are displayed in the *Status* pane.

ISDN/T1-CAS/PSTN

Name	Status	Starts At	ID	Dial-in Number	Entry Password	Numeric Id	H323 Service Prefix
Marketing		Feb 04, 2...	14633	6866686	7777	1478	686
test		Feb 04, 2...	14625	5662332		0385	617

For a description of the Status and Monitor pane columns, see *MGC Manager User's Guide*, Volume I, Chapter 5.

Undefined Dial-in ISDN Participants

Undefined ISDN participants dial-in to a conference directly using the dial-in number provided by the conference organizer or the MGC Manager operator. If necessary, add the country code and area code.

Undefined Dial-in H.323 Participants

Undefined participants connect to the conference by entering the IP Network Service Prefix and the Entry Queue conference Numeric ID or name in the following format: **[IP Network Service Prefix][Numeric ID/Name]**.



For conferences defined as *Meet Me per Conference* or *Meeting Rooms*, the Network Service prefix is displayed in the *Status* pane of the MGC Manager.

Dial-in SIP Participants

SIP participants can connect directly to a conference by entering the conference URI in the format: **name@domain name**

The SIP address is displayed in the *Network Service Properties* dialogue box, *DNS Settings* tab, *Local Domain Name* field.

Defining Standard Audio Only Conferences and Reservations

About Conferences

The MGC unit enables you to run different types of conferences, use different scheduling methods and provide different methods of connecting to the conference.

Conference Scheduling Methods

The MCU system supports both scheduled and on-demand conferences. Scheduled conferences are arranged ahead of time or just before the conference starts. On demand conferencing enables participants to immediately start and connect to an On Going Conference from their endpoint, with no advanced scheduling.

Scheduled Conferences

Scheduled conferences are arranged ahead of time or just before the conference starts. The scheduling can be done by means of the MGC Manager application, by using the browser based WebCommander application or by means of Microsoft Outlook using the MGC Personal Scheduler Add-On. These conferences are deleted from the MCU when they end.

On Demand Conferencing

The MGC environment offers two methods for on demand conferencing:

- Ad Hoc Conferencing
- Meeting Rooms

In Ad Hoc conferencing, participants connect to an Ad Hoc-enabled Entry Queue. Meeting Rooms are conferences that have no allocated resources on the MCU or a starting date and time. They are created once but remain on the MCU in Passive mode and can be activated as many times as required. When the conference ends, the conference reverts to the passive Meeting Room mode until the next activation. It remains in the MCU memory (configuration) and in the Meeting Rooms list. For a detailed description of Ad Hoc Conferencing, see, MGC Manager User's Guide, Volume II, Chapter 3, "Ad Hoc Conferencing and External Database Authentication".

The Meeting Room is activated when the first participant connects to it. The conference connection information is given to all other participants by the Meeting Room owner. The Meeting Room is terminated when the last participant disconnects from the conference or when the chairperson leaves the conference, depending on the conference settings. However, Meeting Rooms can be manually terminated at any time by the MGC Manager operator, or by the conference chairperson via the WebCommander or by using the appropriate DTMF code.

On Going Conferences

An On Going Conference is a conference that has already started. An On Going Conference is created to start immediately or was pre-set previously and the scheduled time to start has arrived.

Reservations

Reservations are conferences scheduled to start at some time in the future. Reservations are defined using the same parameters as On Going Conferences with the addition of the conference start date and time.

When defining a Reservation, you can also schedule a recurrent conference. Each occurrence is deleted from the MCU when it ends.

Attended and Unattended Conferences

Audio Only conferences can be managed by an Operator who takes an active part in the conference, or they can run unattended while the participants manage the conference themselves with the meeting organizer who optionally has additional privileges.

All conferences can be set as *Unattended* or *Attended* mode. All conferences are set as **Unattended** unless the *Attended* mode is selected in the IVR Service or Entry Queue Service when selecting the *On Hold for Operator*

Assistance option. When selected, callers must wait for the operator to connect them to the conference.

In IVR-enabled conferences, in both *Attended* and *Unattended* modes, the participants or meeting organizer can control certain aspects of the conference. Operator assistance is available upon request.

Unattended Conference

An unattended conference is usually a reservationless conference that is started by the first participant who connects to the conference. This type of conference is set up once, to be activated by the participants when required. Although an operator is not needed for this conference, one can be on hand. In an unattended conference, it is the conference chairperson who controls all features and functions of the conference either by means of the touch-tone telephone, another DTMF input device or through the Internet using the WebCommander application. Conference participants can perform simple operations (such as muting or unmuting their lines or modifying their volumes) from their touch-tone telephone or DTMF input device. Actions that can be performed by the participants or the chairperson, are defined in the IVR Service that is assigned to that conference.

Attended Conference

An attended conference is an Operator Assisted conference. It is a service designed usually for large conferences that require the personal touch. In the attended conference, the connection to the conference is controlled by the operator and, in many instances, the operator also takes part in the On Going Conference. In many attended conferences, the name and the telephone numbers of each dial-out participant are given to the operator at the time the reservation is made. This information is used to define the participants prior to the conference start in the MGC Manager or the WebCommander applications. Using the enhanced tools for attended participants, the operator or coordinator organizes the conference call, makes sure all invited participants are on hand, calls the participants then sees to it that the conference proceeds according to plan. If the Entry Queue Service assigned to the Entry Queue used for conference access is set to Attended mode (On Hold for Operator Assistance), when the participants connect to the Entry Queue, they are automatically moved to the Participants Queue where they wait for the operator to connect them to the conference.

In the same way, an IVR Service can be configured to Attended mode. Then all participants connecting to the conference are automatically moved to the

Participants Queue, where they wait for the operator to connect them to the conference. Usually, the Attended mode is configured either at the Entry Queue level or the conference level but not for both

The On Going Conference can also be managed by the conference participants or the chairperson without the operator's assistance. The operations that can be performed by the participants and chairperson are configured in the IVR Service assigned to the conference.

Participants Queue

In the Participants Queue, the system lists participants who require the operator's assistance to connect to the conference, during the conference or were placed on hold - in any conference, regardless of the conference they belong to. The Participants Queue is intended for Attended conferences. Using special toolbars, command buttons and options provided in the *Participants Queue* window, the operator can easily connect participants to their destination (Home) conference.

Conference Types

There are three types of conferences:

- **Standard** - is a conference that is started once, and when the conference ends, it is deleted from the MCU. You can schedule a series of recurring reservations with the same parameters for each reservation in the series. Once defined, each of the reservations is treated as a single, unique reservation that can be modified (except for its name) or deleted from the MCU. For detailed description of Reservations and recurring Reservations, see "Scheduling a New Reservation" on page 2-41.
- **Meeting Room** - is a conference that has no allocated resources on the MCU or a starting date and time. It is defined once but can be activated many times. For more details, see Chapter 5, "Meeting Rooms" on page 5-1.
- **Operator** - a private, one-on-one conference that enables the Operator to assist participants without disturbing the On Going Conferences, or without being heard by other conference participants. An Operator Conference can have up to two participants only: the operator and a participant. For more details, see Chapter 7, "Defining an Operator Conference" on page 7-5.

Both Standard and Meeting Room conferences have the same conference parameters. The difference between them is the method by which they are scheduled and started, and what happens to the conference once it ends.

IVR and Entry Queue Services

Interactive Voice Response (IVR) is an application that allows participants to communicate with the conferencing system over the telephone or through their endpoint's input device (such as a remote control). IVR automates the connection to the conference process and enables the participant to perform various operations during the On Going Conference. By combining the input of the caller with the menu-driven scripts, participants can call the conference dial-in number and use a touch-tone telephone or the endpoint's remote control to interact with the conferencing system. The IVR Services are assigned at the conference level, and different conferences may use different IVR Services, or the same IVR Service may be used for all conferences.

The Entry Queue Service is a subset of the IVR Service and behaves in the same way. An Entry Queue is a special routing lobby to which one or several dial-in numbers are assigned. Participants connect to this lobby and are routed to their destination conferences according to the conference Numeric ID or password that they enter using touch-tone signals (DTMF codes). Different Entry Queues can be defined for video and Audio Only participants, or the same video Entry Queue can be used by audio and video participants provided that the audio algorithm is set to G.711 (telephone standard). Entry Queues remain in a passive state when there are no participants in the queue and they are automatically activated when a participant dials the Entry Queue number.

For more information on Entry Queue definition, see Chapter 5, "Meeting Rooms and Entry Queues".

MCU Configuration and Audio Only Conferences

The functional modules (cards) installed in the MCU determine what kind of conference can run on the MCU.

The Audio+ card is required to run IVR-enabled conferences and Entry Queue and Audio Only conferences. If no such card is available, an error message is displayed when defining any of these conferences.

T1-CAS participants are supported only with the Audio+12/24, Audio+24/48 and Audio+48/96 cards.

It is not possible to mix an ISDN Network Service and a T1-CAS Network Service on the same Net-2/Net-4/Net-8 Network Interface module. Therefore, to run both ISDN and T1-CAS conferences simultaneously, you must install two separate the Net-2/Net-4/Net-8 cards. IP or IP+ cards are required to run conferences that include VoIP participants.

IP+ cards from version 4.23 or higher are required for conferences that include SIP participants. IP (12 or 24) cards are sufficient for H.323-only conferences.

The VTX 1000 connection is supported with the Audio+12/24, Audio+24/48 and Audio+48/96 cards and the MGC-25.

Participant Roles

Conference participants can have different functions: a standard participant, a chairperson, or an operator.

- **Standard participant** - takes part in the conference, performing basic operations via the telephone using the touch-tone signals (DTMF codes). Participants can control their broadcasting and listening volume, mute or unmute their line, request operator's assistance, invite new participants to the conference, vote and ask questions. The functions that participants can perform are defined in the IVR Service. In some cases, a standard participant can have the same privileges as the chairperson.
- **Chairperson** - takes part in the conference but is also the meeting's organizer. The chairperson interacts with other participants in the same conference, and can control the conference using a Web browser or the DTMF codes. Chairpersons perform all the functions of the standard participant but have additional privileges. They can start a voting session, grant the floor to participants who wish to ask questions, mute and unmute participants, connect and disconnect participants, define themselves participant as the conference speaker while muting all other participants and place participants on hold. Some chairperson functions can be performed only via the Web browser. Functions that can be performed using the DTMF codes, are determined in the IVR Service.
- **Operator** - can perform all the chairperson's functions and additional operator-specific functions. The operator can control and monitor all On Going Conferences simultaneously as well as perform general configuration and maintenance operations, but does not have to participate in a conference in order to control it. During On Going Conferences, the operator can move participants from one conference to another, assist participants who need help, terminate the conference before its scheduled time and join the conference. In addition, operators can identify participants as VIPs, move them up or down in the Q&A queue, and give them special attention. Operators perform all activities via the MGC Manager or the MGC WebCommander.

Participant Connection to Conference

Participant connection to a conference is determined by the connection type (dial-in or dial-out), conference type (Attended, Unattended) and service (IVR, Entry Queue, Meet-Me Per Conference).

Participant Connection Types

Conference participants can connect to the conference by calling the conference (dial-in) or when the conference initiates the call to the participant (dial-out) at the beginning of or during the On Going Conference.

Conferences can include only dial-in participants, only dial-out participants or both kinds of participants.

Dial-in Participant

In a conference that includes dial-in participants, the participants may be defined in advance and identified by their Calling Line Identifier (CLI) number, IP address or alias once they connect to the conference. The conference can include anonymous, undefined participants, who were not defined by the operator or meeting organizer prior to the conference start. They connect to the conference if they dial the conference dial-in number and have entered the appropriate password (if one was assigned to the conference), or by means of an Entry Queue. Conferences that include undefined dial-in participants must be defined as *Standard - Meet Me Per Conference* or *Meeting Room* conferences.

Dial-out Participant

In a conference that includes dial-out participants, participants can be called individually by the meeting organizer or by the operator or automatically by the system. In the automatic (blast dial-out) mode, the system treats the participants as a group and calls them all to connect them to the conference. Dial-out participants must be defined by the meeting organizer or operator, usually during the conference definition.

Conference Access for Dial-in Participants

A conference may be accessed directly by dial-in participants or through an Entry Queue or conference IVR queue.

Direct Dial-In Access

Participants can dial directly into the conference using the following methods:

- Using the MCU dial-in number and defining the participants prior to the conference start. Participants are provided with the MCU dial-in number. When they connect to the MCU they are routed to their corresponding conference according to their Calling Line Identifier (CLI) number.
- *Meet Me Per Conference* - Assigning a dial-in number to each conference and defining the conference as Meet Me, allowing undefined participants to connect to the conference.

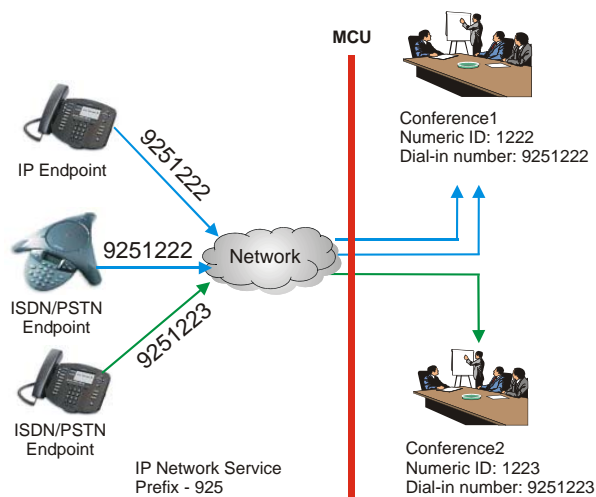

Figure 2-1: Direct Conference Access

The meeting organizer or operator assigns a dial-in phone number to each conference designated as a *Meet Me Per Conference* or *Meeting Room*. The conference dial-in number is given to all the conference participants who use it to directly connect to the conference. Using this mode, any participant who dials the conference number can connect to the conference until all the MCU resources are utilized or the maximum number of participants is reached.

The *Meet Me Per* conference is the basis for the Meeting Rooms definition.

H.323 participants dial the IP Network Service Prefix and the conference numeric ID. To simplify matters, the Network Service Prefix and the ISDN number prefix can be set to be the same number as the local phone exchange (e.g. 925) and the conference Numeric ID can be a four digit number matching the ISDN number allocated to the conference (e.g. 1222), so participants who dial 9251222 connect to conference1.

SIP participants connecting within the organization, dial the conference name or numeric ID. For example, Conference1 or 1222.

Such a conference may be defined as:

- *Standard with Meet Me per Conference and Allow Undefined Participants selected (No Entry Queue Access or IVR)*
- *Meeting Room with Allow Undefined Participants selected (No Entry Queue Access or IVR)*

For more information about Meet-Me per Conference and Meeting Rooms, see Chapter 5, “Defining a New Audio Only Meeting Room”, page 5-4.



In all conferences with “undefined” dial-in participants, the conference or Entry Queue dial-in number may be automatically assigned by the MCU. The number is taken from the dial-in numbers defined in the ISDN/T1-CAS Network Service.

Entry Queue Access

Entry Queue is a call routing method in which all participants dial the same dial-in number. Participants are guided by voice prompts which are part of the Entry Queue Service. The Entry Queue makes it possible to use a limited number of PSTN/ISDN/T1-CAS dial-in numbers for all the conferences and to use toll-free numbers for conferences which are charged to the meeting organizers.

Entry Queues that were defined for video conferencing can also be used for Audio Only conferences, so there is no need to define separate Entry Queues for Audio Only conferences. When the Entry Queue Access option is designated for a conference, the participants connecting to that conference follow a two-stage process:

1. Participants connect to an Entry Queue, where they are routed to their conference in one of two ways:
 - Automatically, according to the Numeric ID or conference password, depending on the MCU configurationor

- Wait for the Operator's assistance. The Entry Queue Service is set to Attended mode (on hold for Operator assistance).
2. Participants join the conference in one of the following ways:
- Directly, without any additional operation from the participant's endpoint.
 - Through the conference IVR queue where they enter the conference entry password, chairperson password or additional information.
 - Wait for the Operator's assistance. The IVR Service assigned to the conference is set to *Attended* mode (On Hold for Operator Assistance).

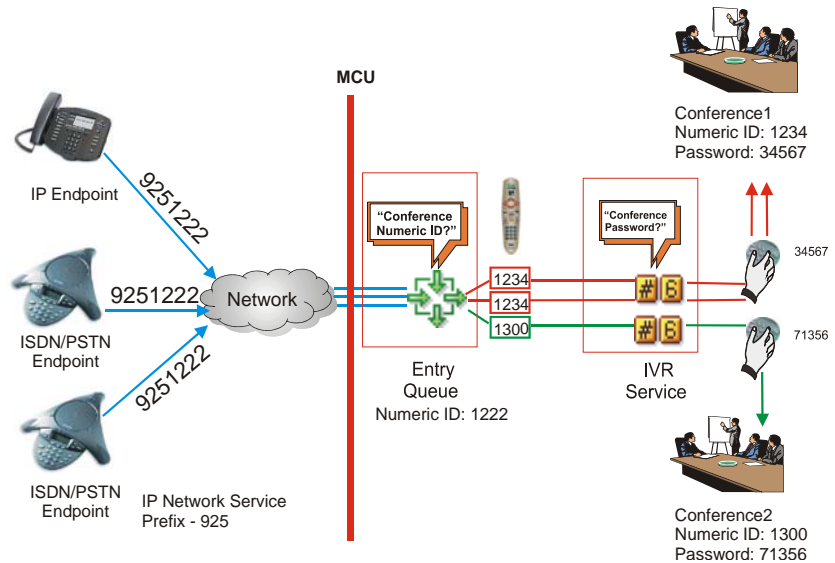

Figure 2-2: Dial-in connection via Entry Queue with Numeric ID

In the example in Figure 2-2, one or several dial-in numbers are allocated to an Entry Queue. In addition, a numeric ID is assigned to each conference and a conference password and chairperson password may be defined. Conference participants are provided with the dial-in number string (H.323) or URI (SIP) and the appropriate conference numeric ID and passwords. When participants dial-in using the number they were given, they connect to the Entry Queue where they are requested to enter the appropriate conference Numeric ID or password, depending on the MCU configuration. According to this numeric ID or passwords, participants are routed to the appropriate conference.

When an IVR Service is assigned to the conference, participants are guided to the conference by voice prompts to use DTMF codes and are requested to enter the required (conference/chairperson) password. They can also be prompted for additional information such as their billing code.

IVR Access

The IVR Service and the Entry Queue Access can be used for Attended and Unattended conferences. The conference password is used to provide security for the conference.

In all Audio and Video conferences, the IVR Service must be assigned to the conference to enable DTMF code input by the participant and chairperson.

In IVR-enabled conferences, the caller enters the conference IVR queue as part of the connection process. Participants connect to the conference IVR queue by dialing the conference dial-in numbers. Using the telephone keypad, participants input the required information to menu driven scripts and voice prompts that are part of the IVR Service. Once the correct information is entered, the participants are connected to the conference.

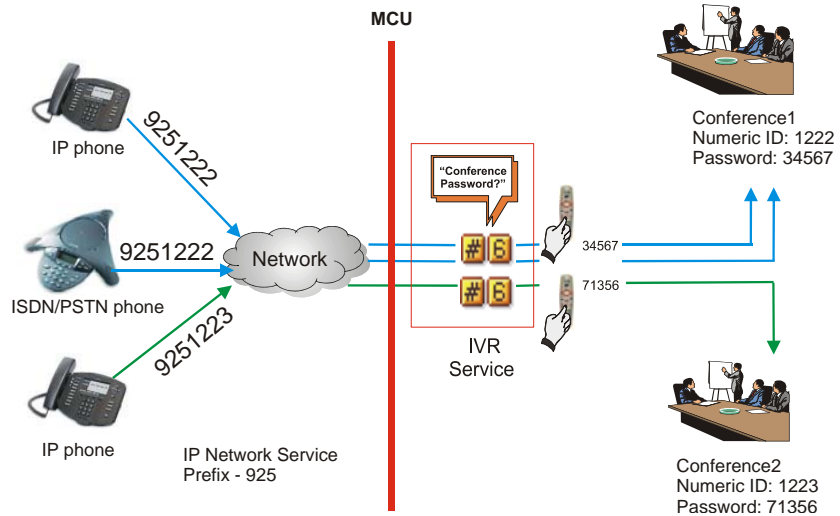

Figure 2-3: Dial-in connection via IVR system

In the example in Figure 2-3, a dial-in number and a numeric ID are assigned to each conference. In addition, an IVR Service is also assigned to the conference. When the callers dial in either the conference dial-in number or

string, they are routed to the appropriate conference, and they enter the conference IVR queue. In the IVR Queue, they are prompted to enter the conference password and other information which they enter using the telephone touch-tone keypads.

The callers are admitted to the conference when they have keyed in the appropriate conference password and/or chairperson password.

In the system, such a conference may be defined as:

- *Standard with IVR Service*
- *Meeting Room with IVR Service*

Conference Access for Dial-out Participants

In unattended Audio Only conferences with no IVR Service assigned to them, dial-out participants (operator dial-out or system dial-out) are connected directly to the conference without going through an Entry Queue or an IVR Queue.

In IVR-enabled Audio Only conferences or in conferences designated as Entry Queue Access, dial-out participants enter the IVR queue where they may be requested to enter the conference password or any digit to confirm the connection.

Defining New On Going Audio Conferences

This section describes how to define a new Standard Audio Only conference.



An Audio+ card must be installed in your MGC unit in order to run an Audio Only conference that uses the IVR Service.

To define an On Going Audio Only Conference:

1. In the *Browser* pane, expand the *MCU* tree.
2. Right-click the *On Going Conferences* icon and then click **New Conference**.

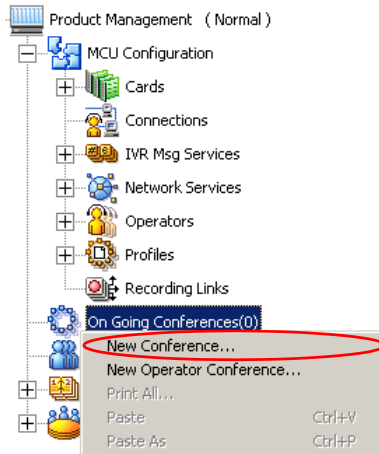

The *Conference Properties* dialog box opens, allowing you to define the various conference parameters.

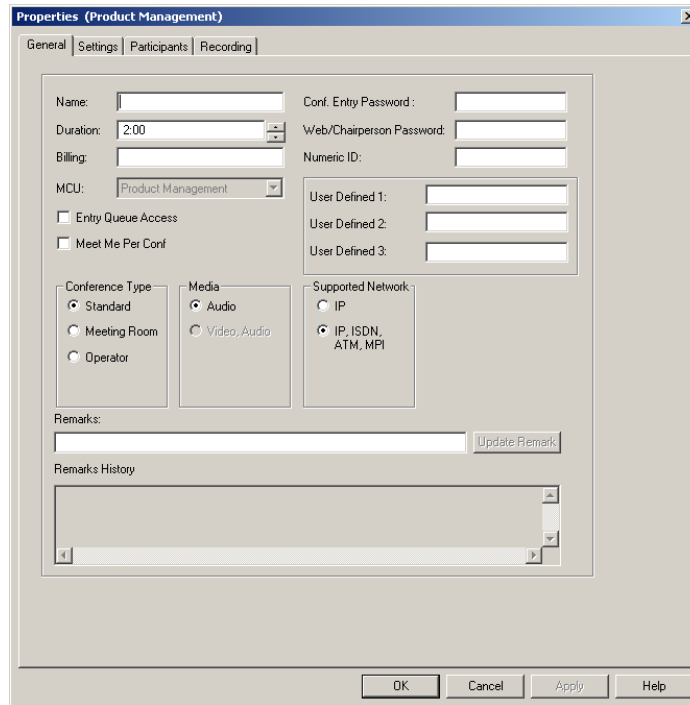

When defining a Standard conference, the *Properties* dialog box shows four setup tabs. The *Meet Me Per Conference* tab is displayed when defining Meeting Rooms and Meet Me Per conferences.

All the properties of an On Going audio conference are logically grouped in these setup tabs:

- *General* – lets you define the basic conference parameters, such as name, duration, password and type of conference access.
- *Settings* – lets you define the conference media options and technical parameters, such as audio algorithm and encryption.
- *Participants* – lets you set options for participant connections, and add participants from the Participants database/template file, or define new participants.

- *Meet Me per Conference* – lets you define the properties of Meeting Rooms and Meet Me Per Conferences. This dialog box is enabled only when the *Meet Me Per Conf* option is selected in the *General* properties or when defining Meeting Rooms.
- *Recording* – lets you define recording options for the current conference.



If you are defining a conference that is accessed through an Entry Queue, you do not need to define the Meet Me per Conference parameters.

General Properties

In the *Conference Properties- General* dialog box, you can define the general properties of an Audio Only conference, such as name, duration, conference type, supported networks and passwords.

3. Define the following *General properties* parameters:

Table 2-1: Conference Properties - General

Field/Option	Description
<i>Name</i>	Enter a unique name using up to 80 characters. Naming the conference is mandatory. Note: If the same name is already used by another conference, Meeting Room, Entry Queue, or Reservation in the same or partially overlapping time frame, when you save the conference on the MCU, an error message is displayed requesting you to enter a different name.
<i>Duration</i>	Define the duration of the conference using the format HH:MM (default 2:00, maximum 99:59). For example, to define a duration of 30 minutes, enter 0:30. For duration of 90 minutes, enter 01:30.
<i>Billing</i>	Enter the conference billing code if one is allocated to the conference. Note: If a reservation system is used, it can allocate a billing code. The Billing code can also be defined by the conference chairperson or by means of the DTMF codes for the conference while the conference is running.

Table 2-1: Conference Properties - General (Continued)

Field/Option	Description
<i>MCU</i>	Displays the name of the MCU to which you are currently connected (read-only).
<i>Conf. Entry Password</i>	<p>Enter a numeric password that participants will need to enter in order to access the conference. If left blank, the MCU automatically assigns the password to the conference once the conference definition is completed (provided the MCU is configured to automatically assign passwords). For more details about the MCU configuration, see the MGC Administrator's Guide, Chapter 5, "Edit system.cfg".</p> <p>Note: This field is applicable only to IVR-enabled conferences that are configured to prompt for the entry password, or to conferences accessed from an Entry Queue using passwords as the routing method.</p>
<i>Web/Chairperson Password</i>	<p>Enter a numeric password for participants to use to identify themselves as the conference chairperson. This password is only required in IVR-enabled conferences that are configured to prompt for the chairperson password.</p> <p>Note: This password is also used to monitor the conference from the WebCommander application.</p>
<i>Numeric ID</i>	<p>A unique Numeric ID (NID) is assigned to each conference as a unique identification number. It is used for accessing the conference from the Entry Queue and as part of the dialing string when dialing into the conference from an H.323 endpoint. The Numeric ID can be assigned manually or automatically.</p> <p>To manually assign the NID, enter a unique number of digits defined in the "system.cfg" file. If you do not assign the Numeric ID, the MCU automatically assigns a number after the completion of the conference definition, when the conference is saved on the MCU.</p> <p>Note: If the MCU is configured to support only automatic assignment of Numeric IDs, then this field is disabled and the system automatically assigns a Numeric ID after you save the conference on the MCU.</p>

Table 2-1: Conference Properties - General (Continued)

Field/Option	Description
<i>Entry Queue Access</i>	<p>Select this option when a single-dial Entry Queue is used for participant access to all conferences. Participants are routed from the Entry Queue to their “Home” conference using the conference Numeric ID or password, depending on the MCU configuration.</p>
<i>Meet Me Per Conf</i>	<p>Select this option to enable undefined participants to connect to a conference by dialing the conference dial-in number. Undefined participants are those who were not defined prior to the conference start.</p> <p>When this option is selected, a dial-in number (ISDN participant) or a string (H.323 participant) is assigned to the conference by the system or manually by the operator. If the Entry Queue Access option is selected for the conference, and you do not want to assign an additional ISDN dial-in number to the conference, do not select this option.</p> <p>Selecting this option activates the Meet Me per Conference tab. To define the <i>Meet Me per Conference</i> properties, see “Defining a New Audio Only Meeting Room” on page 5-4.</p> <p>Note: If a conference is set as both Entry Queue Access and Meet Me Per Conf to which a separate ISDN dial-in number is assigned, participants can connect to the conference by means of the Entry Queue and directly using this number. If you do not require the direct dialing to the conference or you want to conserve the number of dial-in numbers, select either the <i>Meet Me Per Conf</i> option or the <i>Entry Queue Access</i> option.</p>

Table 2-1: Conference Properties - General (Continued)

Field/Option	Description
<i>User Defined</i> 1-3	<p>Enter general information for the conference, such as the company name, contact person's name, email or telephone number, or any other required information.</p> <p>Note:</p> <ul style="list-style-type: none"> • <i>User Defined</i> fields are displayed only if the <i>Show User Defined Fields in Conference Parameters</i> option is selected in the <i>Database Manager -> Defaults -> User Defined Defaults</i>. • The titles of the <i>User Defined</i> fields can be modified in the <i>Database Manager -> Defaults -> User Defined Defaults</i> and loaded to the MGC Manager application. For a detailed description on how to load the user defined default titles, see the MGC Manager User's Guide, Volume I, Chapter 3.
<i>Conference Type</i>	<p>Select the type of conference:</p> <ul style="list-style-type: none"> • Standard – Select this option to define a conference that will be deleted from the MCU once it is terminated, and whose resources are allocated to its participants at the end of the definition process. • Meeting Room – Select this option to define a conference that remains permanently on the MCU. It exists inactive, without resource allocated to it and can be activated repeatedly, when the first participant connects to it. It is terminated when the last participant exits. • Operator – Select this option to define an Operator Conference. An Operator Conference enables Operator Assistance and managing participant connections to the conference in attended conferencing services.
<i>Media</i>	<p>Select <i>Audio</i>, to define an Audio Only conference.</p> <p>Note: In the <i>Audio Look and Feel</i> mode, Audio is automatically selected.</p>

Table 2-1: Conference Properties - General (Continued)

Field/Option	Description
<i>Supported Network</i>	<p>Select the type of network to be used by the conference participants.</p> <ul style="list-style-type: none"> • IP – Only SIP and H.323 participants can join this conference. <p>Note: This option enables you to select an audio algorithm specially suited for IP networks.</p> <ul style="list-style-type: none"> • IP / ISDN / ATM / MPI / T1-CAS – Participants using all types of network connections can join this conference.
<i>Remarks</i>	<p>Using up to 300 characters, you can enter any text regarding the conference. This text will be included with the conference properties and is also saved to the CDR file as part of the conference record to be retrieved later.</p> <p>To add a new remark, enter text in the <i>Remarks</i> box, and then click the Update Remark button.</p> <p>Note: If the text is too long, split it into several remarks, updating the text after each remark. At the scheduling stage, only one remark can be entered. Additional remarks can be entered during the On Going Conference.</p>
<i>Remarks History</i>	<p>Displays all remarks that were entered or updated for this conference by operators and were saved to the CDR file. This field can be read during the conference but not at the reservation stage. Entries are shown in ascending order (latest entry showing at top of list).</p>

Settings Parameters

- Click the **Settings** tab to define the conference settings.

The *Properties - Settings* dialog box opens.

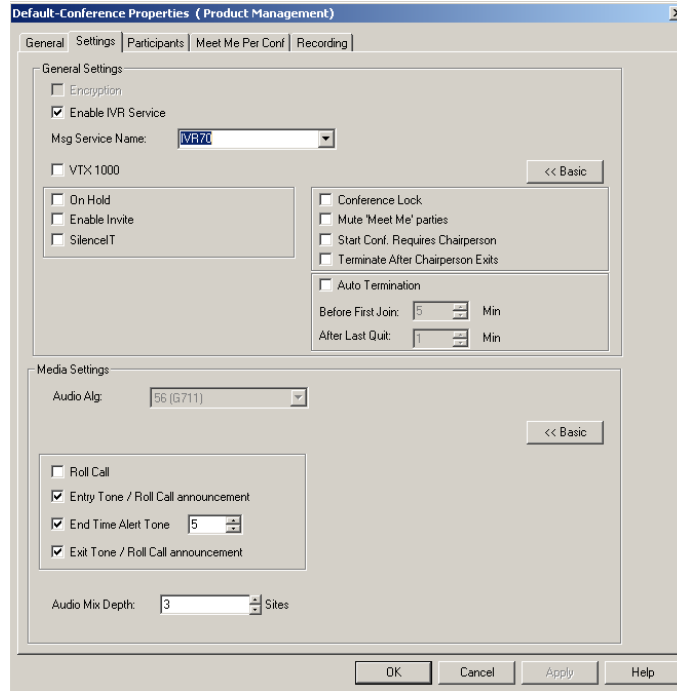

The setup parameters in the *Conference Properties - Settings* dialog box are grouped in two main panes: *General Settings* and *Media Settings*. By default, only the *Basic* settings are displayed when you first open this dialog box. These are the parameters that you will usually need to modify.

- If you want to change the system defaults for the advanced parameters, click the **Advanced >>** button to view and modify additional settings for each of the main panes.

The *Advanced* options remain on display until you click the <<**Basic** button again. The MGC Manager remembers the last dialog box setting.



In most conference definitions you do not need to modify the Advanced parameters.

All the fields in the *Settings* dialog box display the default values defined in the *MGC Database Manager - Conference Defaults* according to the conference type selected in the *Properties - General* dialog box.

For more details on the Conference Defaults definition, see the MGC Manager User's Guide, Volume II, "Using a Database".

6. Define the following basic settings:

Table 2-2: Conference Properties - Basic Settings

Field/Option	Description
General Settings - Basic	
<i>Encryption</i>	<p>If you are defining an IP Only conference, select this option to enable data encryption on the conference level. In that case, all participants must be encrypted in order to connect to the conference.</p> <p>Note: This option is enabled only in IP Only conferences. For a detailed description, see the MGC Manager User's Guide Volume II, Chapter 1, "Advanced Conference Settings".</p>

Table 2-2: Conference Properties - Basic Settings (Continued)

Field/Option	Description
<i>Enable IVR Service</i>	<p>Select this option to enable IVR (Interactive Voice Response) Services for the conference. IVR Services enable voice menus for guiding participants' connections to conferences and interacting with the conference from the participant or chairperson telephone using touch-tone telephone codes (DTMF). When the IVR Service option is enabled, additional fields are activated.</p> <p>When the IVR Service is disabled, the participants are unable to use DTMF codes to control the conference or perform any operation during the conference.</p> <p>If <i>IVR Service</i> is disabled and the <i>Entry Queue Access</i> is enabled, participants connect to the conference directly from the Entry Queue.</p> <p>If <i>IVR Service</i> and <i>Entry Queue Access</i> are disabled, only defined participants can connect to the conference. Undefined dial-in participants can connect only if the <i>Meet Me Per Conf</i> option is enabled for the conference. For detailed information about IVR Message services and setup, see Chapter 5, "IVR and Entry Queue Services".</p>
<i>Message Service Name</i>	<p>Select the IVR Service to be used during this conference from the list of currently defined IVR Message Services. The IVR Message Service includes voice messages to be played when participants wait in the IVR queue or during the conference. It also includes DTMF codes for operations participants can perform during the conference.</p> <p>Note: If left blank, the default IVR Service is used (if one is set as default). For more details, see Chapter 5, "Setting an IVR Message Service as Default".</p>

Table 2-2: Conference Properties - Basic Settings (Continued)

Field/Option	Description
<i>VTX 1000</i>	Select this option if participants are using the VTX 1000 PSTN endpoint for the same wide band, high quality audio used by video participants. The connection between the VTX 1000 and the conference is established through a modem, and therefore it requires the allocation of wide band resources. These resources are allocated and maintained throughout the call, even if the call disconnects or drops to narrow band mid call. Note: VTX 1000 must be enabled at the MCU level in the <i>system.cfg</i> file. For a detailed description of the flag, see MGC Administrator's Guide, Chapter 5, "Edit <i>system.cfg</i> ".
General Settings - Advanced	
<i>On Hold</i>	Select this option to place the conference on hold. While in the On Hold state, all the participants hear the background music. Clear this check box to reinstate the conference. Note: A conference on hold can be released and placed on hold during an IVR-enabled On Going Conference.
<i>Enable Invite</i>	Select this option to enable the Invite feature. When selected, participants in the conference are able to invite new participants during the On Going Conference. In this mode, the participants are moved out of the conference temporarily and can dial-out to the invitee. Note: This option can be enabled only during the conference definition stage of an IVR-enabled conference.
<i>SilenceIT</i>	Enables automatic muting of noisy lines during IVR-enabled conferences.
<i>Conference Lock</i>	Select this option to lock the conference to undefined (Meet Me) dial-in participants and prevent them from joining the conference once it has started. Note: A locked conference can be unlocked during an On Going Conference.

Table 2-2: Conference Properties - Basic Settings (Continued)

Field/Option	Description
<i>Mute Meet Me Parties</i>	<p>Select this option to automatically mute all undefined dial-in participants once they are connected to the conference. The participants can then be individually unmuted by the operator or the conference chairperson (through the WebCommander).</p> <p>Note: Valid for <i>Meet Me Per Conference</i>, <i>Meeting Rooms</i> and <i>Entry Queue Access</i> conferences and reservations.</p>
<i>Start Conference Requires Chairperson</i>	<p>Select this option to indicate that the conference will only start when the participant defined as a chairperson connects to the conference.</p> <p>The amount of time the conference waits for the chairperson to connect (before it is automatically terminated) is defined by a flag in the <i>system.cfg</i> file. Participants who connect to the conference while waiting for the chairperson to connect are automatically placed on hold and hear background music.</p> <p>When the check box is cleared, the conference will start at its predefined time or when the first participant connects to it.</p> <p>Note: This option is enabled only when an IVR Service is assigned to the conference.</p>
<i>Terminate Conference after Chairperson Exits</i>	<p>Select this option to automatically end the conference once the conference chairperson disconnects from the conference. After the chairperson exits the conference, the conference shuts down.</p> <p>Note: This option is enabled only when an IVR Service is assigned to the conference.</p>
<i>Auto Termination</i>	<p>Select this option to automatically end the conference as defined by the <i>Before First Join</i> and <i>After Last Quit</i> fields.</p> <p>Empty conferences still use resources that were reserved for them. By ending the conference, this option saves resources and billing costs.</p>
<i>Before First Join x Min</i>	<p>No participant has connected to the conference for a predetermined time, and the conference is idle. The period is defined in the <i>Before First Join x Min</i> field.</p>

Table 2-2: Conference Properties - Basic Settings (Continued)

Field/Option	Description
<i>After Last Quit x Min</i>	All the participants have disconnected from the conference, and the conference is idle for a predetermined time. The period is defined in the <i>After Last Quit x Min</i> field.
Media Settings - Basic	
<i>Audio Alg</i>	<p>This parameter determines the audio compression ratio. The higher the ratio, the more processing resources are required. Select the preferred audio algorithm for the type of conference you define:</p> <ul style="list-style-type: none"> • 56(G711) 56(G711) – (default). In mixed network conferences this is the only available option and therefore the field is read-only. • 8(G729/G723.1) – Available only for VoIP (IP Only) conferences. <p>Note: When the <i>VTX 1000</i> check box is selected, the system automatically uses the G.722.7 algorithm for the connection between the endpoint and the conference.</p>
<i>Roll Call</i>	<p>The Roll Call feature of the IVR Message Service is used to record participants names and to play them back when participants enter or leave a conference. The chairperson can request the system to play the names of all connected conference participants at any time during the conference.</p> <p>To enable this option, the <i>Roll Call</i> option and fields must be enabled in the IVR Service assigned to the conference.</p> <p>Note: If the <i>Roll Call</i> option is disabled for the conference but enabled in the assigned IVR Service, the participant name is still recorded since the Roll Call can be enabled by the chairperson during the On Going Conference.</p>

Table 2-2: Conference Properties - Basic Settings (Continued)

Field/Option	Description
<i>Entry Tone / Roll Call Announcement</i>	Select this option to play an audio tone to all connected participants when a new participant connects to the conference. (This tone is not heard by the connecting participant.) The tone is embedded in the MGC unit. If the <i>Roll Call</i> option is enabled for the conference, the Entry Tone is replaced by a playback of the recorded participant name followed by a message "... has joined the conference".
<i>End Time Alert Tone x Min</i>	Select this option to play the end of conference reminder tone. This tone is played once, to all the connected participants, x minutes before the end of the conference. The tone is embedded in the MGC unit. At the same time that the tone is played, the <i>Conference</i> icon is replaced with the <i>End of Conference</i> icon. Note: If Auto Extend (automatic extension of the conference) is enabled for the MCU in the "confer.cfg", selecting this option also enables the automatic extension of conference duration for this conference. For more details see the MGC Administrator's Guide, Chapter 5, "MCU Utilities."
<i>Exit Tone / Roll Call Announcement</i>	Select this option to play the exit tone to all the connected participants when a participant disconnects from the conference. The tone is embedded in the MGC unit. If the <i>Roll Call</i> option is enabled for the conference, the Exit Tone is replaced by a playback of the recorded participant's name and the voice message "... has left the conference".
<i>Audio Mix Depth</i>	Indicate how many of the loudest voices speaking at the same time will be heard. The value 3 indicates that the three loudest participants speaking at the same time will be heard. Maximum number of participants that can be mixed is 5.

Participants

Participants can be added to the On Going Conference either by selecting the participant templates from the Participant database or by defining them.

When defining a participant during the definition of an On Going Conference, or after it has started, the participants default parameters are set according to the conference media and type. For example, when defining the participant during an On Going Audio Only conference, only Audio participants can be defined.

Dial-in participants can be defined or undefined. Undefined dial-in participants can connect to an Entry Queue Access conference, a Meeting Room or a Meet Me Per Conference, without prior scheduling as long as they know the conference dial-in number, the conference password or numeric ID (depending on the MCU configuration) and the conference start date and time. This mode is usually used in unattended, conferences.

New Participants can be defined in one of the following methods:

- From the *Conference Properties* dialog box when scheduling the conference or during the On Going Conference.
- From the conference right-click menu or the *Add Participant* icon during On Going Conference.

Participant template that is stored in the Participant Database or in the User Template file can be used to add participants to conferences without defining their parameters. The parameters are taken from the template. The definitions of the Participant Template in the User Template or in the Participants Database are described in the MGC Manager User's Guide, Volume II.

To add participants to a conference:

- Click the **Participants** tab to add participants to the conference. The *Properties - Participants* dialog box opens.

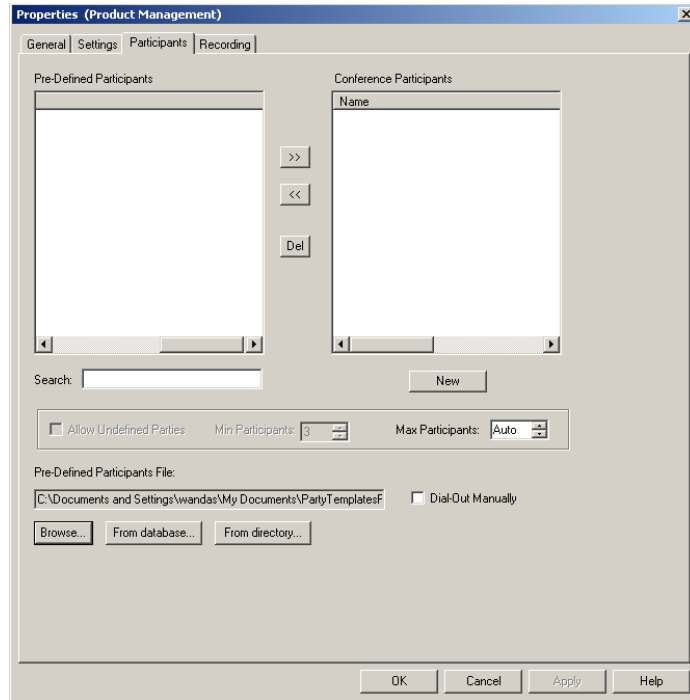

If the conference includes dial-out participants, they should be defined here or assigned from a template. You have to define whether the dial-out participants will be automatically called by the MCU at the conference start time or if they will be manually connected by the operator or conference chairperson.

If the *Meet Me Per Conf* option is selected in the *Properties - General* tab, you can allow undefined dial-in participants to connect to the conference by selecting the *Allow Undefined Participants* option. This

option is automatically selected (and cannot be cleared) when defining Meeting Rooms or Entry Queue Access conferences.



T1-CAS participants can be connected to conferences if T1-CAS is enabled for the conference. The appropriate flag must be set in the *system.cfg* file and a T1-CAS Network Service must be defined in the system. For more information, see the Administrator's Guide, Chapter 3, "Completing the T1-CAS Network Service Definition" and "Assigning the T1-CAS Network Service to the Net-2/Net-4/Net-8 Card".

8. If required, add participants to the conference using the following options:

Table 2-3: Conference Properties - Participants

Field/Option	Description
<i>Pre-Defined Participants</i>	Lists the names of participants defined in the source file that contains predefined participants. The source can be a Participant database, User template file or an LDAP directory (when available). The list is empty if no source was selected in the <i>Pre-Defined Participant</i> file box, or if no participant was defined. To list participants in this box, select the appropriate source file in the <i>Pre-defined Participants</i> file box.
<i>Search</i>	Use this option when the list is very long, to display only those participant names that match a particular character string. Type the string in the <i>Search</i> text box. As each character is typed, all participants starting with the specified character string are displayed in the <i>Pre-Defined Participants</i> list.

Table 2-3: Conference Properties - Participants (Continued)



Field/Option	Description
<i>Pre-Defined Participants File</i>	<p>Displays the full path and file name of the selected User Template file or database from which the <i>Pre-Defined Participants</i> list is read.</p> <p>To select the appropriate participant template source:</p> <ul style="list-style-type: none"> • Click From Database to select another database Group. The <i>Open Parties in Database</i> dialog box opens, letting you select the database and Group from which the Participant templates should be listed. • Click Browse to load a different User Template file, and use the standard Windows convention to locate the required file. • Click Directory to list participants defined in an LDAP-compatible directory.
<i>Conference Participants</i>	Lists the names of the participants who are currently assigned to the conference.
 <i>Add Participant</i>	<p>To add selected participants from the selected database Group, User Template file or LDAP directory to the conference:</p> <ul style="list-style-type: none"> • Click the name of the participant in the <i>Pre-Defined Participants</i> list. • Click the Add Participant (>>) button. <p>The participant's name appears in the <i>Conference Participants</i> list.</p>
 <i>Delete Participant</i>	<p>To remove a participant from the conference:</p> <ul style="list-style-type: none"> • Click the name of the participant in the <i>Conference Participants</i> list. • Click the Delete Participant button. <p>The participant's name is removed from the <i>Conference Participants</i> list and from the conference but not from the database or User Template file.</p>

Table 2-3: Conference Properties - Participants (Continued)

Field/Option	Description
<i>Allow Undefined Parties</i>	<p>Select this option to let undefined participants to connect to the conference. When enabled, undefined participants can connect to the conference until the maximum allowed number of participants (<i>Max Participants</i>) is reached, or until the MCU resources allocated to the conference are used up.</p> <p>Note: This option is automatically selected when the <i>Meet Me per Conf</i> or <i>Entry Queue Access</i> options are selected in the <i>Properties - General</i> tab.</p>
<i>Min Participants</i>	<p>Define the total number of participants for which the system reserves resources. This number should include defined as well as undefined participants.</p> <p>For example, if the conference includes two defined participants (dial-in or dial-out) and you want the system to reserve resources for three additional undefined participants, enter 5 in the <i>Min Participants</i> box.</p> <p>If you enter 0, no resources will be reserved for the conference. Participants will be able to connect to the conference if there are available resources.</p> <p>Note: The total number of conference participants is limited by the value set in the <i>Max Participants</i> parameter, or by the maximum number of participants per conference supported by the MCU.</p>
<i>Max Participants</i>	<p>Enter the maximum number of participants who can connect to the conference at one time. The maximum number is calculated taking into account both the defined and undefined participants.</p> <p>Use this option to save resources for other conferences.</p> <p>When set to Auto, the maximum number of participants is determined by the maximum number of participants in a conference as supported by the MCU, or the by the availability of MCU resources.</p>
<i>Dial-Out Manually</i>	<p>Select this option to designate an operator-controlled dial-out conference connection. When this option is checked, the participants remain in standby state until the operator manually connects each of the dial-out participants to the conference.</p>

Table 2-3: Conference Properties - Participants (Continued)

Field/Option	Description
<i>New</i>	<p>Click this button to define a new participant and add to the list of participants of this On Going Conference. You can save the new participant defined by this method (during the conference definition), in the database or in the current User Template file that is listed in the <i>Pre-Defined Participants File</i> box.</p> <p>If you do not save the new participant's definition in the database or in the User Template file, the participant's properties will be deleted once the On Going Conference ends.</p> <p>For a detailed description of participant definition, see "Defining Participant Properties" on page 2-49.</p>

9. Use one of the following methods to list participants in the Predefined Participants list and add participants to the conference:

- Add participants from the database
- Add participants from the User Template file

To list participants from the database:

- a. Click the **From database...** button to display the list of participants stored in the database in the *Pre-Defined Participants*. If you are not logged into the database, the *Database* dialog box opens.

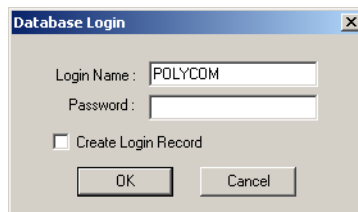

- b. Enter your *Login Name* and *Password* and click **OK**. The *Open Parties in Database* dialog box opens.

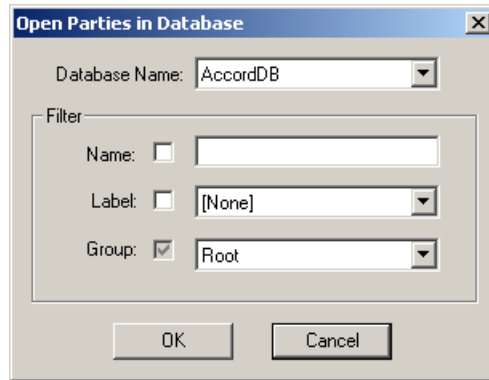

- c. If more than one database is configured in your system, select the appropriate database from the *Database Name* list.
- d. Filter the list of participants by clicking the *Name* and/or *Label* check boxes, entering the appropriate character string in the *Name* field and/or selecting the appropriate label from the drop-down list.

The *Group* option is enabled by default, displaying the highest group in the Groups hierarchy to which the logged in user has access. You may select another group from the Groups hierarchy list. Only groups to which you have access, are listed in the *Groups* list.

- e. Click **OK**. The list of all the participants in the filtered category is displayed in the *Pre-Defined Participants* list, and the name of the participant's Group is displayed in the *Pre-Defined Participants File*. You can now add names from this list to the Conference Participants.
- f. In the *Pre-defined Participants* list, select the participants to add to the conference and click the **Add** >> button.

To add participants from the User Template file:

- a. Click the **Browse** button to list the User Template files stored on your computer. The *Browse* dialog box opens letting you select the User Template file (.usr).

- b. Using standard windows conventions, select the User Template file and click **Open**.
The participants in the User Template file are listed in the *Pre-defined Participants* list.
- c. In the *Pre-defined Participants* list, select the participants to add to the conference and click the **Add** >> button.

Recording

This dialog box is used to enable recording the audio channel of the conference. It is intended for use with the *ReadiRecorder*.

To enable recording for an On Going Conference:

10. Click the **Recording** tab.
The *Recording* dialog box opens.

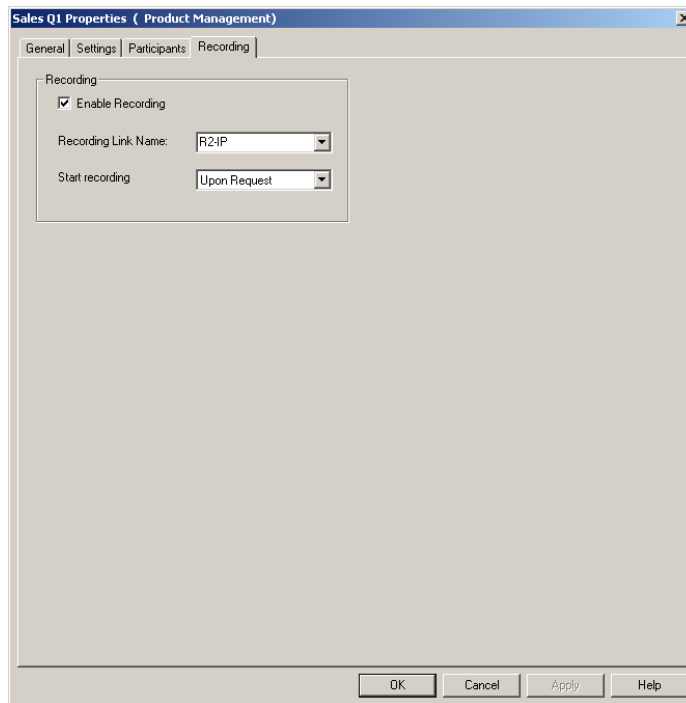

11. Define the following parameters to record the audio channel of the conference:

Table 2-4: Conference Properties - Recording

Field/Option	Description
<i>Enable Recording</i>	Select this option to enable recording.
<i>Recording Link Name</i>	If you enabled recording, select the required Recording Link from the list of the defined links. If left blank, the default recording link will be used. The recording link defines the connection parameters between the conference and the recording system. Note: To view the Recording Links defined for the MCU, double-click Recording Links under the <i>MCU Configuration</i> icon.
<i>Start Recording</i>	Select when to start recording the conference: <ul style="list-style-type: none"> • Immediately - when the conference starts, even if no participant is connected • Upon Request - the recording starts when the chairperson sends the appropriate request by DTMF codes or by the MGC Manager operator.

For more information about recording the audio channel of a conference, see chapter 8, "Recording".

Completing the Conference Definition

12. To complete the conference definition procedure, click **OK** from any of the *Conference Properties* tabs.

The *Properties* dialog box closes. If all the properties are configured correctly, and if there are sufficient MCU resources to run the conference, the new conference is added to the On Going Conferences list in the *Browser* pane of the main window, and starts immediately. You can click the conference icon to view the status data in the *Status* and *Monitor* pane of the MGC Manager main window.

Resolving Scheduling Conflicts

Upon completion of scheduling a Reservation or an On Going Conference, the system checks for scheduling conflicts for individual participants.

A scheduling conflict for a participant results when two or more conferences are set up to occur at the same time or at overlapping times and contain one of the following parameters:

- Participants with the same name
- Participants with the same ISDN or T1-CAS phone numbers
- Participants with the same IP address or Alias

Depending on the connection type that was defined for the participant, MGC Manager looks for specific conflict criteria to determine if the participant is double-booked. Table 2-5 lists these criteria:

Table 2-5: Scheduling Conflict Criteria by Connection Type

Connection Type	Conflict Criteria
<i>Dial-out (ISDN/ PSTN/T1-CAS</i>	Name or phone number(s).
<i>Dial-out IP</i>	Name and IP address or Alias. IP address and Alias (when both provided).
<i>Dial-in</i>	Name or phone number.

If a conflict is detected in the reservation or in an On Going Conference, the *Participants Scheduling Conflicts* window opens, listing the found data.

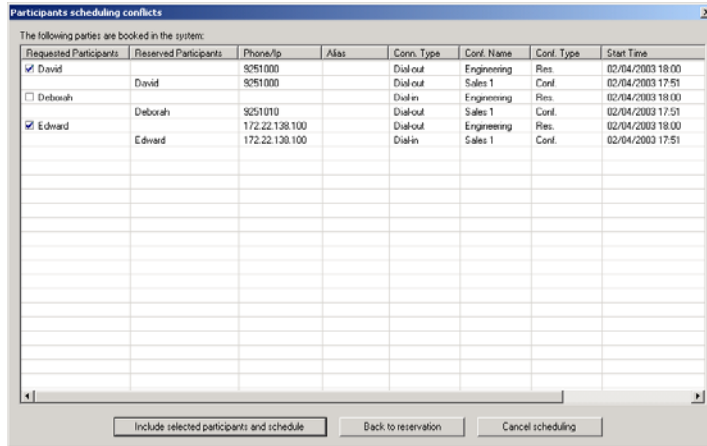

The following information is displayed:

Table 2-6: Participants Scheduling Conflicts Table

Field/Option	Description
<i>Requested Participants</i>	Lists the names of conflicting participants requested to join the conference currently being created.
<i>Reserved Participants</i>	Lists the names of participants already scheduled in previously created conferences whose data match those of the newly requested participant.
<i>Phone/IP</i>	Lists the phone numbers or IP addresses of all listed participants.
<i>Alias</i>	Lists the aliases of all listed participants.
<i>Conn. Type</i>	Indicates the participant's connection type: <ul style="list-style-type: none"> • Dial-in – participants call the conference • Dial-out – the system calls the participant For the description of connection types, see "Participant Connection to Conference" on page 2-8.
<i>Conf. Name</i>	Lists the names of the conferences in which each participant is defined.

Table 2-6: Participants Scheduling Conflicts Table

Field/Option	Description
<i>Conf. Type</i>	Indicates the conference type: <ul style="list-style-type: none"> • Res. – Reservation • Conf. – On Going Conference
<i>Start Time</i>	Date and start time of each conference.
<i>End Time</i>	Date and termination time of each conference.



The MGC Manager application checks for conflicts on the MCU on which the reservation is being scheduled, while the WebCommander application checks for conflicts on multiple MCUs.

To resolve the scheduling conflicts for participants:

- In the *Participants Scheduling Conflicts* table, select an action:
 - Select the (check boxes of) non-conflicting participants in the Requested Participants column, to retain these participants in the currently scheduled conference.

or

 - Clear the (check boxes of) conflicting participants in the Requested Participants column, to exclude these participants from the currently scheduled conference.
- Select the required solution, by clicking the appropriate button:
 - Include selected participants and schedule** - Select this option to allow the system to ignore the found conflict information and to schedule the conference.
 - Back to reservation** - Select this option to return to the current conference definition without scheduling the conference and to modify the required parameters or select other participants.
 - Cancel scheduling** - Select this option to cancel the current conference definition and exit the conference definition mode.

The window closes and the selected action is applied.

Listing On Going Conferences

In the *On Going Conferences* list, you can view all conferences that are currently running.

To view the On Going Conferences:

1. Expand the *MCU* tree, and then expand the *On Going Conferences* tree.



The number of On Going Conferences appears between brackets next to the *On Going Conferences* icon and the conferences that are currently running are listed below. Each conference is identified by its name, and an icon indicating its type and general status.

On first entry, or if no conferences are running, the On Going Conferences list is empty. Additional information regarding the On Going Conferences can be viewed in the *Status* pane.

Scheduling a New Reservation

A Reservation is a conference that is scheduled to start sometime in the future. It is saved on the MCU and is automatically started when the scheduled date and time arrives. At the end of the conference it is deleted from the MCU.

To schedule a new Reservation:

1. Expand the MCU tree.
2. Right-click the *Reservations* icon, and then click **New Reservation**.



The *Conference Properties - General* dialog box opens, allowing you to define the general parameters of the conference. These parameters are identical to the standard conference General parameters.

3. Define the conference general parameters, such as name, Numeric ID, passwords and duration. For detailed description of these parameters, refer to Table 2-1, "Conference Properties - General." on page 2-16.
4. Click the **Scheduler** tab to schedule the conference start date and time. The conference will automatically start at the defined date and time.

The *Properties - Scheduler* dialog box opens. By default, the system displays the current time as the start time of the conference.

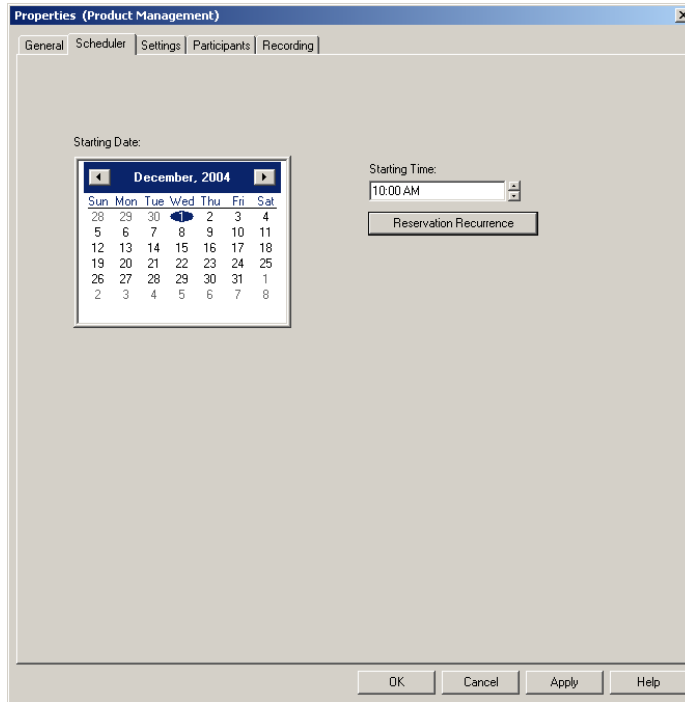

If you do not change the default date and time (current), the defined Reservation becomes an On Going Conference and will start immediately.

- Define the following parameters:

Table 2-7: Reservation Properties - Scheduler

Field/Option	Description
<i>Calendar</i>	Select a date on which the conference should be started; select the month and year on the calendar, and then click the date.

Table 2-7: Reservation Properties - Scheduler (Continued)

Field/Option	Description
<i>Starting Time</i>	To select a time at which the conference should be started, set the starting time using either the 12H AM/PM or the 24-hour format. (The time format is derived from the Operating System time format defined in the Regional Settings.) Highlight the hours or minutes in the box and either use the spin buttons to modify the displayed time, or type a time directly.
<i>Reservation Recurrence</i>	Click this button to define a reservation for a conference that will be repeated on a regular basis, using the same basic parameters. For more details, refer to "Defining Recurrent Reservations" on page 2-44.

6. Click the **Settings** tab.
The *Conference Properties - Settings* dialog box appears.
7. Define the *Settings* parameters, as described for the On Going Conference, "Settings Parameters" on page 2-21.
8. Click the **Participants** tab to add defined participants (mainly dial-out) either from a template or to define a new participant. If *Meet Me Per Conference* is selected, access this tab if you want to define the number of participants for which the system should save resources and the maximum number of participants allowed to connect to this conference. For details, see Table , "Defining Participant Properties," on page 2-49.
9. If the *Meet Me Per Conference* option was selected in the *General* tab, click the **Meet Me Per Conf** tab.
The *Conference Properties - Meet Me Per Conf* dialog box appears.



This tab appears only if the Meet Me Per Conference option is selected in the General tab.

10. Define the Meet Me Per Conf parameters as described in MGC Manager User Guide Vol I, Chapter 2.
11. Click **OK** to complete the Reservation definition.
The new Reservation is added to the Reservations list.

Defining Recurrent Reservations

You can set up conferences to occur repeatedly by defining the recurrence pattern (frequency and day) and range (number of recurrences or the date on which they will end). The number of duplicate reservations is derived from the number of occurrences defined for the reservation. Each duplicate includes the same parameters of the original conference, however, except for the *Conference Name*, you can modify these parameters for the individual conference. Defining the *Reservation Recurrence* parameters can be done in two ways:

- When setting up a New Reservation from the *Reservations* list.
- When setting up a New Reservation from a *Reservation Template*.

The recurrence parameters are defined in the *Conference Properties - Scheduler* dialog box.

To define the recurrence parameters for the reservation:

1. In the *Conference Properties - Scheduler* dialog box, select the month, year and day of the first conference, and the conference *Starting Time*, as described in Table 2-7, “Reservation Properties - Scheduler,” on page 2-42.
2. Click the **Reservation Recurrence** button.

The *Reservation Recurrence* dialog box opens.

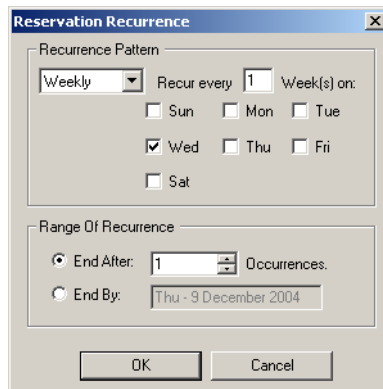

3. Define the following parameters:

Table 2-8: Reservation Recurrence Settings

Field/Option	Description
<i>Recurrence Pattern</i>	<p>Select the recurrence frequency:</p> <ul style="list-style-type: none"> • Daily – By default, all the days of the week are selected. To exclude a certain day of the week (for example, the weekend), clear the check box. • Weekly – By default, the system selects the day of the week as set in the <i>Scheduler</i> calendar for the first reservation. You can also define the recurrence interval in weeks. For example, if you want the reservation to occur every 2 weeks, enter the value 2 in the <i>Week(s) on</i> box. To define a reservation that recurs twice a week, select an additional day of the week at which the conference is to be repeated and set the interval to 1.
<i>Recurrence Pattern (cont.)</i>	<ul style="list-style-type: none"> • Monthly – By default, the system sets the day according to the day defined for the first conference. You can choose either the day of a month or a schedule sequence: • Daily – By default, all the days of the week are selected. To exclude a certain day of the week (for example, the weekend), clear the check box. • Weekly – By default, the system selects the day of the week as set in the <i>Scheduler</i> calendar for the first reservation. You can also define the recurrence interval in weeks. For example, if you want the reservation to occur every 2 weeks, enter the value 2 in the <i>Week(s) on</i> box. To define a reservation that recurs twice a week, select an additional day of the week at which the conference is to be repeated and set the interval to 1.

Table 2-8: Reservation Recurrence Settings (Continued)

Field/Option	Description
<i>Range of Recurrence</i>	<p>Define the range of reservation recurrences:</p> <ul style="list-style-type: none"> • End After [number of] Occurrences – Specify after how many recurrences the reservation will end. The default value is 1; the range is 1-2000. • End By [date] – Specify the date for the last occurrence of the recurring reservation. If you select the Range of Recurrence - End By option, the Reservation Recurrence dialog box expands to show the calendar in the Ending Date Of Recurrence pane. Click the required date in the displayed calendar month or select a different month using the scroll arrows. <p>Note: The MGC Manager calculates the number of occurrences according to the selected frequency and the date range.</p>

4. Click **OK** to apply the settings.
The *Reservation Recurrence* dialog box closes. The Scheduler settings of the reservation are completed.
5. Define the remaining conference parameters, as described in Table 2-7, “Reservation Properties - Scheduler,” on page 2-42.
6. Click **OK** to complete the definition of the new reservation.
Once the reservation has been defined, the system automatically creates the recurring reservations. The name of each of the recurring reservations is derived from the name of the first reservation, followed by sequential numbers, using the format <name>_X, where X is its sequential order. For example, if the first reservation is named “Demo”, and the number of occurrences is three, the system creates three reservations, naming the first “Demo_1”, the second “Demo_2” and the third “Demo_3”.

Listing Reservations

The Reservations defined on the MCU are stored in the *Reservations* list.

To view the Reservations list in the Browser pane:

- Expand the MCU tree, then expand the *Reservations* tree. The reserved conferences are listed in the *Browser* pane below the *Reservations* icon.



The number of currently defined reservations appears between brackets next to the *Reservations* icon. Each conference is identified by its name, and an icon indicating the Reservation type and status.

You can view Reservations in the *Status* pane to check additional information about the Reservation, such as its Numeric ID, passwords, dial-in numbers and H.323 Network Service Prefix.

Displaying the List of Reservations in the Status Pane

- Expand the MCU tree and in the Status pane and click the *Reservations* icon

Name	Status	Starts At	Duration	ID	Dial-in Number	Numeric ID	Entry Password	Chair Password
↳ ...								
Polycom Sales_ 1	O.K.	Oct 30, 2003 05:00:00 PM	02:00:00	2272	100	2501	005418	028345
Polycom Sales_ 2	O.K.	Oct 31, 2003 05:00:00 PM	02:00:00	2273	100	2501	005418	028345
Security_ 1	O.K.	Oct 30, 2003 06:00:00 PM	02:00:00	2278		1735		
Security_ 2	O.K.	Nov 30, 2003 06:00:00 PM	02:00:00	2279		1735		
Transitions_ 2	O.K.	Nov 06, 2003 04:30:00 PM	02:00:00	2277		1759	008405	007253

End of Conference Reminder

At a certain time during a conference, the *End of Conference Reminder*  icon can appear in the *Status* or *Monitor* panes, reminding you (the operator) that the conference is due to end. You can then extend the duration of the conference if necessary.

The time interval between the moment that the *End of Conference Reminder* is displayed and the scheduled end of the conference, is a predefined parameter that you can configure using the **Conf Alert** function of the MGC Manager *Options* menu.

To define the End of Conference Reminder:

1. On the *Options* menu, click **Conf Alert**.
The *Conference End Time Alert* dialog box opens.

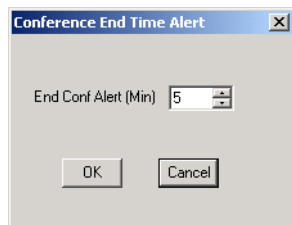

2. In the *End Conf Alert* field, enter or select the value that defines how many minutes before the end of the conference the *End of Conference Reminder* is activated. For example, if you enter 5, the *End of Conference Reminder* icon will be displayed five minutes before the end of the conference.
Entering 0 disables the appearance of the warning icon.
3. Click **OK** to apply the setting.
From this point on, the system will display the *End of Conference Reminder* icon x minutes (where x is the value entered in the *End Conf Alert* field) before the end of any On Going Conference. The icon remains on display until the conference ends.



You can extend the duration of the On Going Conference, when needed. For details, see Chapter 4, "Changing the Conference Duration" on page 4-53.

Defining Participant Properties

New participants can be defined directly during the conference definition or during the On Going Conference. You can also define participant templates either in the Participant Templates Database or the User Template file

To define a new participant:

1. Use one of the following methods to open the *Participant Properties - Identification* dialog box opens.
 - a. In the *On Going Conference Properties - Participants* dialog box, click the **New** button.
 - b. Expand the *On Going Conferences* list, right-click the icon of the conference to which to add the participant, and then click **New Participant**.
 - c. Expand the *On Going Conferences* list, click the icon of the conference to which to add the participant, and then click the **New Participant** button  on the Conference toolbar.
 - d. Expand the *On Going Conferences* list, click the icon of the conference to which to add the participant, and then press the shortcut key (default key is <F8>)

The *Participant Properties - Identification* dialog box opens.

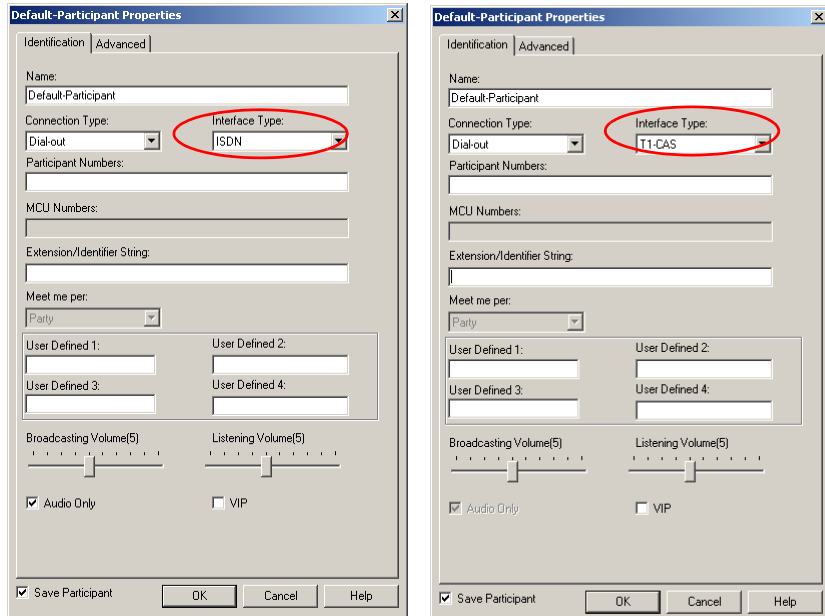

2. Define the following parameters:

Table 2-9: Participant Properties and Identification Dialog Box

Field/Option	Description
<i>Name</i>	Enter a unique name for the participant, using up to 80 characters.
<i>Connection Type</i>	<p>Select the connection type:</p> <ul style="list-style-type: none"> • Dial-in – Participants call the MCU at conference time. You provide the participant with the MCU's dial-in number. When selecting this type, the <i>Meet Me Per</i> options are enabled. This connection type is applicable to ISDN, ATM and MPI interfaces. <p>Note: Dial-in T1-CAS participants can only connect as undefined participants.</p>

Table 2-9: Participant Properties and Identification Dialog Box (Continued)

Field/Option	Description
<i>Connection Type</i> (cont.)	<ul style="list-style-type: none"> • Dial-out – At the predefined conference start time, the MCU calls the participant. When defining the participant, you must enter the participant's number. <p>Note: This is the only selection available for the T1-CAS participant. If the <i>Dial-Out Manually</i> option is disabled in the <i>Conference Properties - Participant</i> tab, the MCU automatically calls the participant at conference time. If this option is enabled, the operator must connect the participant.</p>
<i>Interface Type</i>	<p>Select the network type used by the participant to connect to the conference:</p> <ul style="list-style-type: none"> • ISDN – for participants connecting via ISDN or PSTN lines. • H.323 – for participants using the H.323 protocol. • SIP – for participants using a SIP Protocol. • T1-CAS – for participants using a Channel Associated Signaling (CAS) connection.

Participant definitions differ according to their selected Interface Types.

ISDN/PSTN/T1-CAS Participant Definition

3. Define the following parameters for ISDN/PSTN/T1-CAS participants

The definition of the *Advanced* parameters may be skipped for most participants, but if you need to change the defaults or define additional settings, open the tab.

Table 2-10: ISDN/PSTN/T1-CAS Properties and Identification Dialog Box

Field/Option	Description
<i>Participant Numbers</i>	<p>This parameter is enabled for the Dial-out connection type, or when the Dial-in <i>Meet Me Per Conference - MCU</i> option is selected.</p> <p>Type the participant's number (including country and area codes when required) to be dialed by the MCU when connecting the participant to the conference.</p> <p>If the <i>Meet Me Per MCU</i> option is enabled, the CLI number is used to identify the participant and route them to the appropriate conference. Enter the participant's CLI number.</p>
<i>MCU Numbers</i>	<p>This field is enabled only to Dial-in, Meet Me Per MCU participants. Enter the MCU number as allocated to the MCU by the carrier. The dial-in numbers are defined in the <i>ISDN Network Services - Span</i> dialog box.</p> <p>If left blank, when the conference starts the MCU automatically assigns a dial-in number from the list of numbers defined in the <i>ISDN Network Service</i>.</p> <p>Note: During an On Going Conference, the MCU numbers are listed in the <i>Network+Phone/IP</i> column of the main window <i>Status</i> pane. The format (number of digits) depends on how the dial-in numbers are forwarded from the PBX switch to the MCU and whether the PBX truncates part of the number.</p>

Table 2-10: ISDN/PSTN/T1-CAS Properties and Identification Dialog Box

Field/Option	Description
Extension/ Identifier String	<p>Used with multi-step extension dialing and participants with PBX or IVR phone extensions. This field is used to enter the required data for the dialing. The string listed in the <i>Name</i> field consists of the following format: (0...9)(Free text)([Ext: Extension)(p)(extension number)(p)(extension number)(p)(##)]. For example, 9Sales[Ext:p345p222p].</p> <p>Each section of the string is explained below:</p> <ul style="list-style-type: none"> • 0...9 - Any digit between 0 and 9, the digit being any number that identifies the participant during a DTMF dial-out sequence. For example, when a chairperson activates a dial-out session by pressing *259, *25 is the DTMF command code that activates the dial-out session and 9 is the number that identifies a particular participant to be used in the session. • Free text - Optional text field, and may be omitted. <p>Note: In conferences where the blast dial-out feature is activated automatically using the DTMF code *25, the free text field must start with a digit as shown in the example: 9Duke[Ext:p345p222p].</p> <ul style="list-style-type: none"> • Brackets [] - Brackets indicating a dial string. Bracket are context sensitive and only this type of format is to be used. • Extension (Ext., ext., EXT: are permitted) text prefix - Code indicating that a string consisting of a series of digits are to be used during dial-up. <p>Note: More than one extension number is optional, certain IVR systems request that you first dial a department and then extension number.</p> <ul style="list-style-type: none"> • p - Induces a pause of 1 second before transmitting the next digit or DTMF code. There is no limit to the number of p's in a dial string <p>Note: When using one second intermissions, it is important to note that each IVR system has different content and timing of dialog sequences. Correct timing for output of DTMF digits might determine whether a call can be successfully completed.</p>

Table 2-10: ISDN/PSTN/T1-CAS Properties and Identification Dialog Box

Field/Option	Description
<i>Meet Me Per</i>	<p>This field is enabled only for Dial-in participants. Select:</p> <ul style="list-style-type: none"> • Party – The participant dials a single number. • MCU-Conference – Select this option when a single dial-in number is used by all dial-in participants connecting to the MCU. The participants are routed to the appropriate conferences according to their CLI number defined in the Participant Numbers field. This option should be used only with PBXs supporting the CLI option.
<i>User Defined fields 1-4</i>	<p>In any or all of the four <i>User Defined</i> fields, enter general information for the participant, such as the participant's email address, telephone number, company name, location, or any required information.</p> <p>The titles of the <i>User Defined</i> fields can be modified in the <i>Database Manager -> Defaults -> User Defined Defaults</i> and loaded to the MGC Manager application.</p> <p>Note: The <i>User Defined</i> fields are displayed only if the <i>Show User Defined Fields in Participant Parameters</i> box is selected in the <i>Database Manager -> Defaults -> User Defined Defaults</i>.</p>
<i>Broadcasting Volume/Listening Volume</i>	<p>You can control the volume of the audio transmitted from the participant to the conference (broadcasting volume), as well as the listening volume for the participant.</p> <p>To adjust the volume, move the slider. The volume scale is from 1 to 10, where 1 is the weakest and 10 the strongest volume. The volume of each endpoint's audio at connection time is set to 5. One movement of the volume slider increases or decreases the volume by one unit, equivalent to 3db.</p>

Table 2-10: ISDN/PSTN/T1-CAS Properties and Identification Dialog Box

Field/Option	Description
<i>Audio Only</i>	When checked, indicates an Audio Only participant. This option is automatically selected and cannot be cancelled: <ul style="list-style-type: none"> • for T1-CAS participants • in Audio Look & Feel mode • when defining participants during Audio Only conference definition in the <i>Conference Properties - Participants</i> dialog box.
<i>VIP</i>	When checked, changes the participant's status to VIP to distinguish participants who require special attention. Note: The VIP status can also be changed during the On Going Conference.
<i>Save Participant</i>	(Optional) When checked, saves the participant definition as a template in the User Defined template file or in the selected Database Group. Note: This check box appears only when defining a participant during conference or reservation definition.
<i>Participant Linked</i>	This check box appears only when defining a participant during the definition of a Reservation template in the database. Select this option to save the participant as a template in the database and link the participant to the Reservation template. The participant is assigned to the selected database Group. If this option is cleared, the participant is embedded in the Reservation template and his/her parameters are not saved in the database as a Participant template for future use.

Table 2-10: ISDN/PSTN/T1-CAS Properties and Identification Dialog Box

Field/Option	Description
<p><i>Label</i></p>	<p>(Optional) This field appears only when participant definition is done directly in the database and displays the label assigned to the participant. The label is used for filtering the Participant Templates list in the database. Non-administrative users can assign only the labels assigned to them. Users with administrator rights can assign any label created in the system.</p> <p>The labels are defined by administrators in the MGC Database Manager module. For detailed information on template types and use, refer to the MGC Manager User's Guide Volume II, Chapter 7, "Database Templates".</p>

4. **Optional:** Click the **Advanced** tab.

The participant's *Properties - Advanced* dialog box opens.

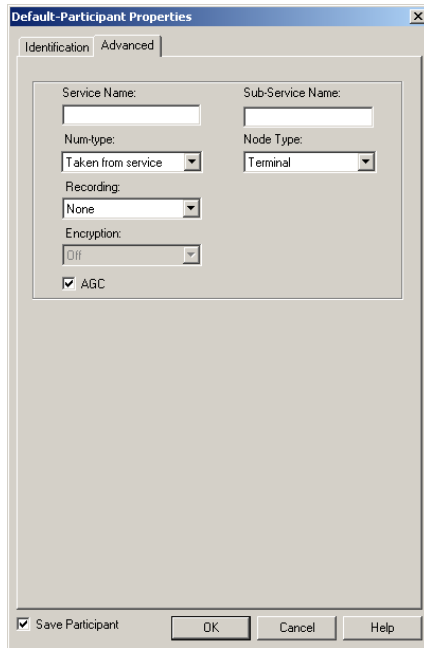

5. If required, define the following parameters:

Table 2-11: ISDN/ATM/MPI/T1-CAS Participant - Advanced

Field/Option	Description
<i>Service Name</i>	<p>Enter the name of the <i>Network Service</i> to be used to connect the ISDN/ATM/MPI/T1-CAS participant to the conference exactly as it is defined in the Network Service list (the system is case sensitive).</p> <p>If left blank, the default <i>Network Service</i> is used, depending on the selected connection type. For example, if the selected connection type is ISDN, the default ISDN Network Service is used.</p> <p>For more information on Network Services, refer to the MGC Administrator's Guide, Volume II, Chapter 3.</p>
<i>Sub-Service Name</i>	<p>This field is applicable to ISDN participants only.</p> <p>If a sub-service is used, enter the sub-service name exactly as it appears in the selected Network Service definition. If left blank, the default sub-service defined in the selected Network service is used.</p>
<i>Num-type</i>	<p>Select the type of program to be used when connecting to ISDN/ATM/MPI participants.</p> <p>The available options are Unknown; National; International; Network Specific; Subscriber; Abbreviated; Taken from Service. These options represent programs provided by the carrier, and are defined in the Network Service. Select Taken from Service to indicate that the program should be retrieved from the Network Service definition.</p>
<i>Node Type</i>	<p>Select the node type from the drop-down list. The available options for ISDN/ATM/MPI participants are:</p> <ul style="list-style-type: none"> • MCU – Select this setting for a dial-out participant in a DTMF Enabled Cascaded conference. For more details, see MGC Manager User's Guide Volume II, Chapter 1. • Terminal (default) – Use this setting at all other times.

Table 2-11: ISDN/ATM/MPI/T1-CAS Participant - Advanced (Continued)

Field/Option	Description
<i>Recording</i>	<p>Designate the ISDN/T1-CAS participant as an audio recording port connected to an external recording device: Select one of the following:</p> <ul style="list-style-type: none"> • None – The participant is not connected to an external recording device. • Dial up – The participant is used as the recording port to an external device. <p>For more details, Chapter 8, "Recording".</p>
<i>Encryption</i>	<p>Media information can be encrypted using an AES 128 algorithm. The <i>Encryption</i> options are affected by the settings of the participant level flag in the system.cfg. For Audio Only participants connecting to an Audio Only conference with mixed networks, Auto is automatically selected. It implies the conference encryption setting (<i>encrypted/non-encrypted</i>) is applied to the participant. Audio Only ISDN/T1-CAS participants cannot be encrypted, because encryption is not part of the ISDN/T1-CAS protocol, and therefore, in this mode the participant can only connect as a standard participant to non-encrypted conferences.</p>
<i>AGC</i>	<p>The Auto Gain Control (AGC) mechanism regulates audio noise and volume by balancing the received signal to all participants. AGC can be applied to all incoming audio streams prior to mixing, thereby dynamically adjusting the amplification of the input signal.</p> <p>AGC is automatically enabled for all participants. Clear this check box to disable this option for the participant.</p>
<i>Save Participant/ Participant Linked</i>	<p>These check boxes are the same as the check boxes that appear in the <i>Properties Identification</i> dialog box. For more information, see the description of the "Save Participant" parameter Table 2-10 on page 2-52.</p>

6. Click **OK** to complete the participant definition.
The participant is added to the On Going Conference, Reservation or the Reservation Template, depending on the conference/participant definition mode.

IP (H.323 and SIP) Participant Definition

If you select *H.323* or *SIP* in the *Interface Type* field, the fields change in the *Participant Properties* dialog box. Most of the parameters are common to both H.323 and SIP participants.

The screenshot shows the 'Properties' dialog box with the 'Advanced' tab selected. The 'Interface Type' dropdown is set to 'H323'. The 'Participant IP' is '0.0.0.0' and the 'Signaling Port' is '1720'. The 'Alias Type' is 'H323 ID'. There are four 'User Defined' input fields. At the bottom, there are sliders for 'Broadcasting Volume[5]' and 'Listening Volume[5]', and checkboxes for 'Audio Only' and 'VIP'. The 'Save Participant' checkbox is checked.

H323 Participant Properties

The screenshot shows the 'Properties' dialog box with the 'Advanced' tab selected. The 'Interface Type' dropdown is set to 'SIP'. The 'Participant IP' is '0.0.0.0' and the 'Signaling Port' is '5060'. There is a 'SIP Address' field and an 'Address Type' dropdown set to 'SIP URI'. There are four 'User Defined' input fields. At the bottom, there are sliders for 'Broadcasting Volume[5]' and 'Listening Volume[5]', and checkboxes for 'Audio Only' and 'VIP'. The 'Save Participant' checkbox is checked.

SIP Participant Properties

7. Define the following parameters:

Table 2-12: H.323 and SIP Participant Properties - Identification

Field/Option	Description
<i>Participant IP</i>	Enter the IP address of the participant's endpoint. <ul style="list-style-type: none"> • For H.323 participants: <ul style="list-style-type: none"> — In a Dial-out connection, enter the IP address or alias of the endpoint to be called by the MCU. If you entered only an alias the gatekeeper can resolve the participant's alias into an IP address. — In a Dial-in connection, the participants IP address or alias are entered. The IP address or alias is used to identify and route the participant to the appropriate conference. • For SIP endpoints, <i>Participant IP</i> is optional as these participants can be located by using their URI addresses.
<i>Signaling Port</i>	Indicates the signaling port used for participant connection. For H.323 the default port is 1720. For SIP, the default port is 5060.
<i>SIP Address</i> SIP Only	Enter the endpoint address in the format: [user name]@[domain]. Note: The SIP URI adheres to URI rules: no spaces or special characters such as commas, quotation marks, inverted tags and so forth either in the user name or in the domain part.

Table 2-12: H.323 and SIP Participant Properties - Identification (Continued)

Field/Option	Description
<p><i>Address Type</i> SIP Only</p>	<p>Select the format in which the SIP address is written:</p> <ul style="list-style-type: none"> • SIP URI – Uses the format of an E-mail address, typically containing a user name and a host name: <i>sip:[user]@[host]</i>. For example, sip:dan@polycom.com. • TEL URI – Used when the endpoint does not specify the domain that should interpret a telephone number that has been input by the user. Rather, each domain through which the request passes would be given that opportunity. As an example, a user in an airport might log in and send requests through an outbound proxy in the airport, not by the user's home domain.
<p><i>Alias Name</i> H.323 Only</p>	<p>If you are using the endpoint's alias and not the IP address, first select the type of alias and then enter the endpoint's alias as registered with the gatekeeper. Enter the alias name using the naming conventions appropriate to the selected Alias type.</p>
<p><i>Alias Type</i> H.323 Only</p>	<p>Select the appropriate alias type before entering an alias name:</p> <ul style="list-style-type: none"> • H.323 ID (alphanumeric ID) • E.164 (digits 0-9, *, #) • URL ID (URL style address) • Email ID (email address format) • Transport ID (IP address: port number) • Party Number (identical to the E.164 format) <p>Notes: Although all types are supported, the gatekeeper capabilities dictate the <i>Alias Type</i> to be used, mainly H.323 ID and E.164. Refer to your gatekeeper documentation for information on its supported alias types.</p>

Table 2-12: H.323 and SIP Participant Properties - Identification (Continued)

Field/Option	Description
<i>Extension/Identifier String</i>	This is the DTMF string sent to the recording or other DTMF activated system; an outgoing DTMF operation initiated by the MCU. This is useful for identifying extensions associated with SIP users. Each type of recording system has a specific DTMF string structure, for example, when using the Prairie recording services.
<i>User Defined fields 1-4</i>	In any or all of the four <i>User Defined</i> fields, enter general information for the participant, such as the participant's email address, telephone number, company name, location, or any required information. The titles of the <i>User Defined</i> fields can be modified in the <i>Database Manager -> Defaults -> User Defined Defaults</i> and loaded to the MGC Manager application. For details, see Chapter 3. Note: The <i>User Defined</i> fields are displayed only if the <i>Show User Defined Fields in Participant Parameters</i> box is selected in the <i>Database Manager -> Defaults -> User Defined Defaults</i> .
<i>Broadcasting Volume/Listening Volume</i>	You can control the volume of the audio transmitted from the participant to the conference (broadcasting volume), as well as the listening volume for the participant. To adjust the volume, move the slider. The volume scale is from 1 to 10, where 1 is the weakest and 10 the strongest volume. The volume of each endpoint's audio at connection time is set to 5. One movement of the volume slider increases or decreases the volume by one unit, equivalent to 3db.
<i>Audio Only</i>	When checked, indicates an Audio Only participant. This option is automatically selected and cannot be cancelled: <ul style="list-style-type: none"> • For T1-CAS participants • In Audio Look & Feel mode • When defining participants during Audio Only conference definition in the <i>Conference Properties - Participants</i> dialog box.

Table 2-12: H.323 and SIP Participant Properties - Identification (Continued)

Field/Option	Description
<i>VIP</i>	When checked, changes the participant's status to VIP, to distinguish participants who require special attention. Note: The VIP status can also be changed during the On Going Conference.
<i>Save Participant</i>	(Optional) When checked, saves the participant definition as a template in the User Defined template file or in the selected Database Group. Note: This check box appears only when defining a participant during conference or reservation definition.
<i>Participant Linked</i>	This check box appears only when defining a participant during the definition of a Reservation template in the database. Select this option to save the participant as a template in the database and link the participant to the Reservation template. The participant is assigned to the selected database Group. If this option is cleared, the participant is embedded in the Reservation template and his/her parameters are not saved in the database as a Participant template for future use.

8. **Optional:** Click the **Advanced** tab.

The *Advanced* parameters definition may be skipped for most participants if the default settings are used.

The *IP Participant Properties - Advanced* dialog box opens.

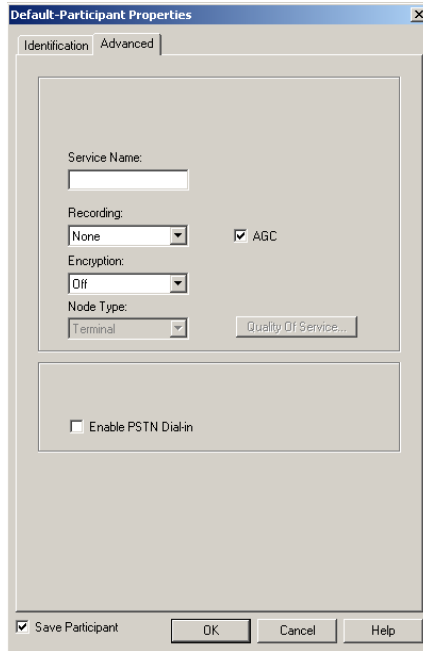

9. Define the following parameters:

Table 2-13: *H.323 and SIP Participant Properties - Advanced*

Field/Option	Description
<i>Service Name</i>	Enter the name of the IP Network Service handling the call. Note that the system is case sensitive. If left blank, the default IP Network Service (H.323 or SIP depending on the Interface Type) is used.
<i>Recording</i>	Designate the IP participant as an audio recording port connected to an external recording device. <ul style="list-style-type: none"> • None – The participant is not connected to an external recording device. • Dial up – The participant is used as the recording port to an external device. For more details, see the MGC Manager User's Guide, VoicePlus edition, Chapter 6.

Table 2-13: H.323 and SIP Participant Properties - Advanced (Continued)

Field/Option	Description
AGC	<p>The Auto Gain Control (AGC) mechanism regulates audio noise and volume by balancing the received signal to all participants. AGC can be applied to all incoming audio streams prior to mixing, thereby dynamically adjusting the amplification of the input signal.</p> <p>AGC is automatically enabled for all participants. Clear this check box to disable this option for the participant.</p>
<i>Encryption</i>	<p>Media information can be encrypted using an AES 128 algorithm. The <i>Encryption</i> options are affected by the settings of the participant level flag in the system.cfg. Select the appropriate encryption setting for the participant:</p> <ul style="list-style-type: none"> • Auto – The conference encryption setting (<i>encrypted/non-encrypted</i>) is applied to the participant. In this mode, the participant connects as encrypted only if the conference is defined as encrypted. • Off – The participant joins the Conference/Entry Queue <i>non-encrypted</i>. • On – The participant joins the Conference/Entry Queue <i>encrypted</i>. <p>Note: SIP participants do not support this type of encryption, and therefore Auto should be selected. For more details, about encryption see the MGC Manager User's Guide Volume II, Chapter 1.</p>
<i>Node Type</i>	<p>Select the node type from the list:</p> <ul style="list-style-type: none"> • Terminal – The default. This setting is applicable for all settings that are not DTMF enabled cascaded conferences. • MCU – Select this setting for a dial-out participant in a DTMF enabled cascaded conference. For more details, see MGC Manager User's Guide Volume II, Chapter 1.

Table 2-13: H.323 and SIP Participant Properties - Advanced (Continued)

Field/Option	Description
<i>Quality Of Service</i>	Click this button to configure QoS for this participant. For details see MGC Manager User's Guide Volume I, Chapter 4, "Quality of Service for IP Participants, page 4-124.
<i>Enable PSTN Dial-in</i>	For internal use only.
<i>Save Participant</i>	(Optional) When checked, saves the participant definition as a template in the User Defined template file or in the selected Database Group. Note: This check box appears only when defining a participant for a Reservation template in the User Template file or when defining a participant during a conference when Database Group is the source.

- Click **OK** to complete the definition of the *H.323* and *SIP* participant. The participant is added to the On Going Conference, Reservation or to the Reservation Template, depending on the conference definition mode.

Dialing-in from an H.323 Endpoint

Simple Dial-in Using the IP Card Address

In simple dial-in, the participant dials the IP address of the IP card installed in the MCU, so no gatekeeper is required. The participant is routed to the destination conference according to the participant's IP address defined for the participant in the conference.

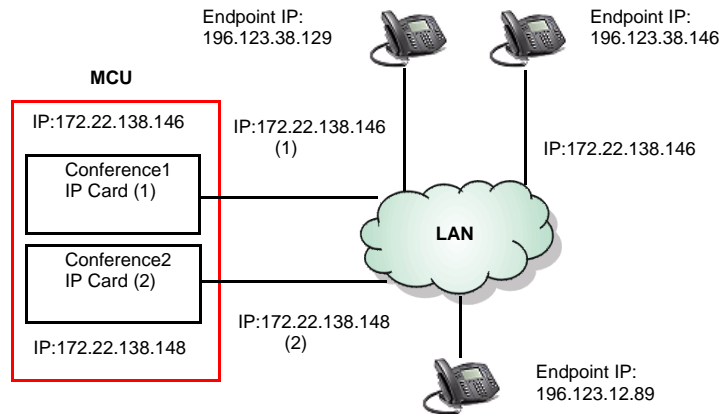

Figure 2-4: H.323 Participant simple dial-in using the IP Card address

In this dial-in mode, the MGC Manager operator must manage the system resources by distributing the participant connections between the cards. This is done by giving the IP address of the appropriate H.323 card to each of the participants.

Simple Dial-in Using the IP Card Alias

Participants can use the alias of the IP card installed in the MCU to dial-in. In this mode, a gatekeeper is required in order to provide address translation and routing to the IP module. When the participant enters the IP card alias, the call is routed to the gatekeeper that forwards the call to the appropriate IP card according to its table of aliases and IP addresses.

For Gatekeeper functionality and interoperability see the *Administrator's Guide, Chapter 3, Defining a H.323 Network Service*.

The MGC Manager determines the conference to which the participant is assigned according to the participant's alias or IP address defined for the participant in the conference.

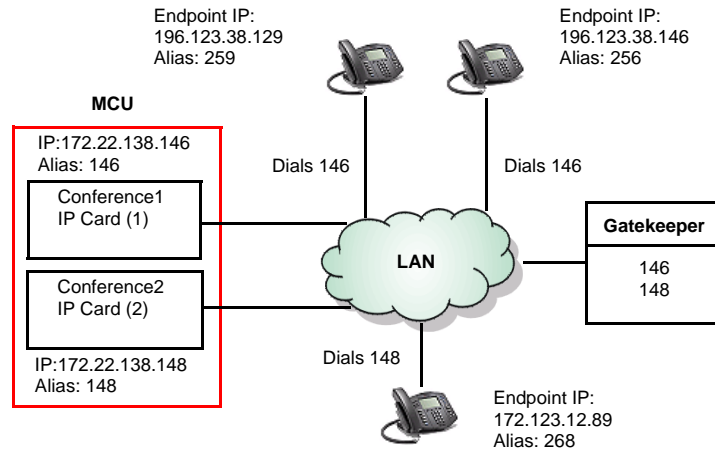

Figure 2-5: H.323 Participant simple dial-in using the IP card alias

H.323 Advanced Dial-in

In this mode, the participant enters a dialing string that is the IP Network Service Prefix. Usually one IP *Network Service* is defined for all the IP cards installed in the MCU. The IP Network Service is registered with the gatekeeper using a prefix. (The prefix is defined using E.164 format, i.e. 0-9 digits, * and #.) This Network Service prefix is also entered in the IP *Network Service Properties - H.323* dialog box. The Network Service prefix is given to the participants as the dial-in number. When the participants dial in, the call arrives at the gatekeeper. The gatekeeper locates the MCU and tries to allocate a port from the first free IP card. If the resource is available, the participant is connected and routed to the appropriate conference according to the participant's IP address/Alias as defined in the *Participant Properties* dialog box. If the resource is unavailable on the first IP card, the system looks for the port on any of the available IP cards, and allocate the resources

automatically, according to their availability. If no port is available, the connection will be rejected.

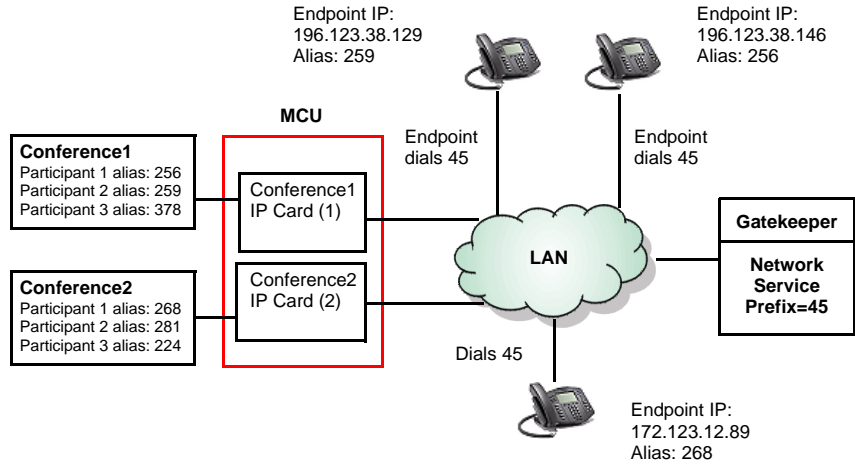

Figure 2-6: H.323 Participant Advanced Dial-in



The Gatekeeper behavior is dependent on the type of Gatekeeper service chosen in the *Service Mode* field (IP Network Service Properties - H.323 dialog box). Currently, only Polycom, RadVision and VCON MXM Gatekeepers are known to support the *Network Service Prefix* option. Gatekeepers of other manufacturers may encounter problems while defining such a conference. For Gatekeeper functionality and interoperability in IP Network Services, see the MGC Manager Administrator's Guide, Chapter 3.

Listing Participants

You can view the updated list of participants in the *On Going Conference* list, in the *Browser*, *Status* and *Monitor* panes.

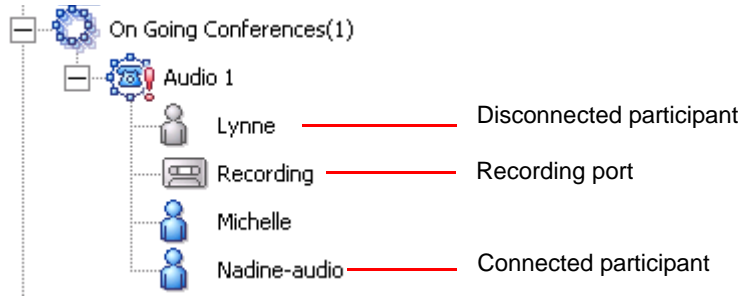

- If *Dial-Out Manually* was selected in the *Conference Properties* dialog box, participants remain disconnected (Stand By state) until the operator initiates the connection from the MCU to the participant. Until all participants connect to conference, the conference shows the “Not Full” status.
- If *Dial-out Manually* was not selected for the conference, the system automatically dials out to all listed participants and connects them to the conference.
- Defined, dial-in participants status is “Waiting for dial-in” until they connect to the conference.

Monitoring On Going Conferences

You can monitor On Going Conferences and perform various operations while conferences are running.

Three levels of monitoring are available with the MGC Manager:

- *General Monitoring* - You can monitor the general status of all On Going Conferences and their participants in the MGC Manager main window.
- *Conference Level Monitoring* - You can view additional information regarding a specific conference and modify its parameters if required, using the *Conference Properties* option.
- *Participant Level Monitoring* - You can view detailed information on the participant's status, using the *Participant Properties* option. During attended conferences you can monitor the status of the participants waiting in the Participants Queue.

This chapter describes the available options and methods of monitoring Audio Only conferences in the MGC *Audio Look and Feel* mode, according to monitoring levels and according to the type of participant or the type of connection to the conference.

When the *Audio Look and Feel* mode is set for the system, the video parameters are hidden, but you can still monitor video conferences if they are run on any of the connected MCUs. The *Audio Look and Feel* mode is set in the *Options* menu. For more details, refer to the MGC Administrator's Guide, Chapter 5, "Audio Look and Feel".

General Monitoring

Monitoring a conference enables you to keep track of its participants and its progress. When monitoring a conference, you can check whether all its participants are correctly connected and whether errors and faults have occurred.

The MGC Manager allows operators to monitor several On Going Conferences simultaneously. Conference chairpersons can monitor only the conference to which they are connected by using the WebCommander application.

You can use the MGC Manager to monitor both unattended and attended conferences. Participants in unattended conferences usually connect to a conference without the operator's assistance. In an unattended conference with an assigned IVR Service, operations are performed using DTMF codes and/or are managed by the chairperson of the conference. Unattended participants can be in two states: Greeting and Conferencing.

In attended conferences, the connection to the conference is controlled by the Operator. In this mode, the participants are moved from one stage to another by the operator using one of the following methods:

- interactive drag-and-drop
- using the right-click pop-up menu
- using the Participants Queue window

For detailed description of attended Audio Only conferences, see Chapter 7, "Attended Conferencing".

Listing On Going Conferences in the Status Pane

The *On Going Conferences* category lists all the On Going Conferences currently running on the MCU. You can view the status of the conferences either by expanding the On Going Conferences tree or by listing the conferences in the *Status* pane.

To view On Going Conferences in the Status pane:

1. In the Browser pane, expand the *MCU* tree.
2. Click the *On Going Conferences* icon.

A list of On Going conferences is displayed in the *Status* pane.

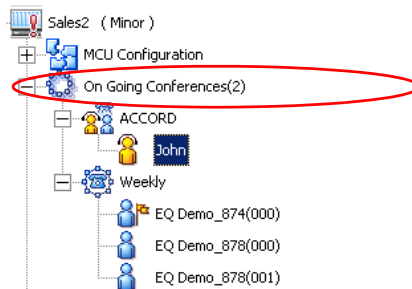

In the *Status* pane, the conference parameters are displayed:

MCU Network	Status	Connection	Starts At	End Time	ID	Dial-in Number
Alpha	ACCORD	Single Participant	Dec 01, 2003 15:22:44	Dec 01, 2003 17:22:44	5338	
Alpha 02	Audio Sales		Dec 01, 2003 15:27:01	Dec 01, 2003 17:27:01	5345	
Alpha 06 (Normal)	Default-Audio	(On Hold)	Dec 01, 2003 15:27:23	Dec 01, 2003 17:27:23	5346	301
MCU Configuration	Default-Conference		Dec 01, 2003 15:23:18	Dec 01, 2003 17:23:18	5341	300
On Going Conferences(5)	Sales		Dec 01, 2003 14:32:14	Dec 01, 2003 16:32:14	5301	
ACCORD						
Audio Sales						
Default-Audio						
Default-Conference						
Sales						
Participants Queue(0)						
Reservations(0)						
Meeting Rooms(0)						

The following conference parameters are listed in the *Status* table:

Table 3-1: On Going Conference Status - Parameters

Column Name	Description
<i>Name</i>	The name of the On Going Conference and an icon indicating the conference type and status. For a detailed description of the various conference and participant icons, see the description of the Monitor pane columns in Table 3-2 On Going Conference - Monitor Pane Columns page 3-7.
<i>Status</i>	Additional information about the conference status, such as Locked or On Hold.
<i>Connection</i>	The connection status of the participant, such as Connected, or Disconnected
<i>Starts At</i>	The actual start date and time of the conference.
<i>End Time</i>	The scheduled end date and time of the conference.
<i>ID</i>	A sequential ID number assigned to the conference by the system for use by the Call Detail Record (CDR) utility.
<i>Connected</i>	The number of participants currently connected to the conference.
<i>Dial-In Number</i>	The number participants can use to dial into the conference from a telephone/ISDN line.
<i>Join Conference</i>	The names of conferences the Operator Conference has joined: <ul style="list-style-type: none"> • Operator Conference – the name of the conference joined by the operator. • On Going Conference – the name of the operator who joined the conference (the operator conference name is identical to the operator's login name).
<i>Entry Password</i>	The password to be used by participants to join the conference.
<i>Chairperson Password</i>	The password to be used by a participant to join the conference as the chairperson.

Table 3-1: On Going Conference Status - Parameters (Continued)

Column Name	Description
<i>Numeric ID</i>	The unique-per-MCU Conference Numeric ID as assigned by the operator or the system.
<i>Encryption</i>	Indicates if encryption is enabled for the conference.
<i>H.323 Service Prefix</i>	The H.323 prefix allocated to the conference.

General Conference and Participant Monitoring

The conference level monitoring allows you to view the status of an On Going Conference and its participants. Conference properties may be displayed in the *Status* pane or in the *Monitor* pane. The *Status* pane enables you to view the properties of one conference at a time. The *Monitor* pane enables you to view several conferences simultaneously. It displays additional parameters and you can filter the display to show only those participants requiring operators assistance.

Monitoring the Conference and Participant Status

To view the status of conference participants in the Status pane:

1. In the *Browser* pane, expand the *On Going Conferences* tree.

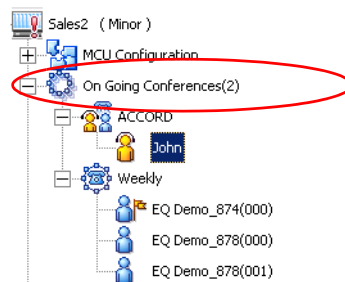

2. Click the icon of the conference whose participants to display in the *Status* pane.

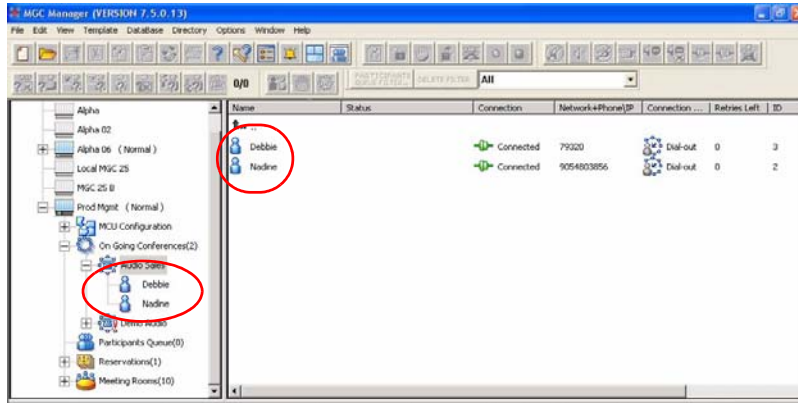

To display the status of conference participants in the Monitor pane:

1. In the *Browser* pane, expand the *On Going Conferences* list.
2. Right-click the icon of the conference to monitor, and then click **Monitor** to view all the conference participants in the monitor pane.

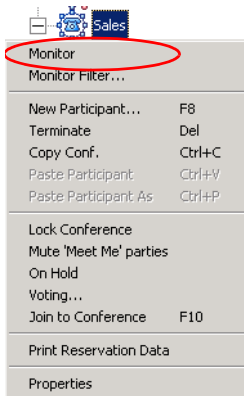

The conference details appear in the *Monitor* pane.

Information is displayed in table form. Each row represents a conference or a participant, and each column represents a status item that is being monitored. You can adjust both the columns and the rows in the Monitor and the Status pane tables to suit your monitoring priorities.

- To modify the order of columns, select and drag the column labels to the desired location.
- To sort items in a column, click a column heading once for descending order, and click again to sort the items in ascending order.
- The Conference Name, Status, Phone#, Connection Type and Retries Left fields appear in both the Status and Monitor pane.

Table 3-2 describes the Monitor pane columns.

Table 3-2: On Going Conference - Monitor Pane Columns



Column Name	Icon	Indication	Description
Name	<i>The name of the On Going Conference or participant, and an icon indicating the conference and participant type and status.</i>		
	Conference Indicators		
		<i>Audio Only conference</i>	This type of conference can be run on an Audio Only MCU (Voice Plus) or on a unified MCU.
	<i>Operator Conference</i>	Audio only. Allows the operator and a single participant to talk in a side conference without disturbing the On Going Conference. For this purpose, the participant is moved to the operator conference from the Entry Queue, IVR queue, Welcome queue, or On Going Conference.	

Table 3-2: On Going Conference - Monitor Pane Columns (Continued)





Column Name	Icon	Indication	Description
<i>Name (cont.)</i>		<i>End-of-conference alert</i>	Indicates that the conference is about to end.
		<i>Faulty audio conference</i>	An exclamation point next to the conference icon indicates that the conference has a problem and requires operator's assistance. The cause of the problem is listed in the Connection column.
		<i>Secure conference</i>	A conference has been secured by the chairperson to prevent outside participants and operators from joining, monitoring or controlling it. For all secure conference statuses, see Table 3-6 on page 3-20.
Participant Indicators			
Dial-in participants who were undefined prior to the conference start, are named using the conference name and a sequential number that appears between brackets.			
		<i>Standard participant</i>	Any dial-in or dial-out participant connected to the conference.
		<i>Chairperson / Leader</i>	The participant defined as the conference chairperson/leader. The chairperson can manage the conference using touch-tone signals (DTMF codes), for example lock or unlock the conference to dial-in participants, initiate a voting session, be the exclusive speaker, mute all other participants.

Table 3-2: On Going Conference - Monitor Pane Columns (Continued)







Column Name	Icon	Indication	Description
<i>Name (cont.)</i>		<i>Operator</i>	The participant defined as the MGC Manager Operator. The operator manages an On Going Conference, connects and disconnects participants, moves participants between conferences, assists participants, and more.
		<i>VIP participant/ VIP chairperson</i>	A participant or a chairperson defined as a VIP, for preferential assistance. The VIP status does not change the role of the participant.
		<i>Questioner/ VIP Questioner</i>	A participant who is currently waiting in the Question-and-Answer queue.
		<i>Current questioner/ VIP Current questioner</i>	The current questioner in a Question-and-Answer session.
	 (Gray)	<i>Disconnected participant</i>	When any type of defined participant is disconnected from the conference, the respective icon is disabled.
		<i>Faulty connected participant</i>	An exclamation point next to the icon indicates that the participant has a problem and requires operator's assistance. The cause of the problem is listed in the Connection column.
		<i>Recording port</i>	This port (telephone) is connected to an external device used for recording the conference.

Table 3-2: On Going Conference - Monitor Pane Columns (Continued)





Column Name	Icon	Indication	Description
<i>Status</i>	Displays additional information about On Going Conferences, their participants, and the number of connected participants. A change in participant status (usually in attended conferences) is also displayed in the Status pane. The possible statuses and their indications are listed in Table 3-3 on page 3-15.		
		<i>Locked conference</i>	The conference is locked to dial-in participants.
		<i>On Hold</i>	The conference is on hold; all participants hear background music.
		<i>On Hold and Locked</i>	The conference was placed on hold and is locked to dial-in participants.
		<i>Voting</i>	Voting session is in progress, where participants express their preference on a set of choices using the touch-tone keypad.
<i>Connection</i>	Indicates the connection status of the conference or a participant when no indication is displayed and the conference is running smoothly.		
	Conference Indicators		
		<i>Empty</i>	No participant was defined for this conference, or none of the defined participants are connected.
		<i>Not Full</i>	Not all the participants who were defined for this conference, are connected.
<i>Faulty Connection</i>		Participants are connected, but the connection is problematic.	

Table 3-2: On Going Conference - Monitor Pane Columns (Continued)



Column Name	Icon	Indication	Description	
<i>Connection (cont.)</i>		<i>Single Participant</i>	Only one participant is defined, or only one of the defined participants is connected.	
		<i>Resource Deficiency</i>	The resources currently installed in the MCU, such as audio cards, cannot handle the requested conference because it exceeds its limitations.	
		<i>Bad Resources</i>	A fault occurred in one of the cards.	
	Participant Indicators			
		<i>Connected</i>	The participant is successfully connected to the conference.	
	 (Gray)	<i>Disconnected</i>	The defined participant is disconnected from the conference. This status may occur when the participant is disconnected from the On Going Conference either by the operator or from the participant side.	
		<i>Connecting</i>	Displayed during the connection process of a participant to the conference.	
		<i>Stand By</i>	In a conference that was set to <i>Dial-out Manually</i> , the dial-out participant is waiting for the MCU call.	
		<i>Waiting for Dial-in</i>	The system is waiting for the defined dial-in participant to dial into the conference.	

Table 3-2: On Going Conference - Monitor Pane Columns (Continued)





Column Name	Icon	Indication	Description
<i>Connection (cont.)</i>		<i>Partial connection</i>	The connection process is not yet complete.
		<i>Faulty Connection</i>	The participant is connected, but problems occurred in the connection, such as synchronization loss.
		<i>Noisy Line</i>	The line of this participant was detected by the system as noisy. Note: This indicator is used only when the automatic noisy line detection option was enabled in the "system.cfg".
<i>Network ISDN/T1-CAS, H.323 or SIP</i>	The type of supported network that the conference is using.		
<i>Participant Numbers\ IP Address\ SIP Address</i>	Displays the participant and MCU phone numbers or IP address/alias, depending on the supported network and connection type. In dial-in connection, displays the CLI number (ISDN) or IP address/alias of the participant calling the MCU (marked by the letter P) and the MCU number or IP address/alias dialed by the participant (marked by the letter M). In dial-out connection displays the dialed number (ISDN), IP address/alias (H.323) or URI(SIP) of the participant.		
<i>Connection Type</i>	Identifies the defined type of participant's connection to the conference.		
		<i>Dial-out</i>	The MCU (conference) dials to the participant.
		<i>Dial-in</i>	The participant calls the MCU (conference).
		<i>Direct connection</i>	Leased Line connection (ISDN only).

Table 3-2: On Going Conference - Monitor Pane Columns (Continued)

Column Name	Icon	Indication	Description
<i>Audio</i>			Indicates whether the participant's audio is connected and the status of the audio channel.
<i>Sync.</i>			Indicates whether the participant's site is synchronized. If Yes, the Media Member field displays the media types that are synchronized. If No, the Media Member field displays the media types that are unsynchronized. For more details, see Table 3-4 on page 3-16.
<i>Tx Rate</i>			The line rate in which data sent <i>from the MCU</i> is received by the endpoint.
<i>Rx Rate</i>			The line rate in which data sent <i>from the endpoint</i> is received by the MCU.
<i>Retries Left</i>			Indicates the remaining number of attempts the system makes to reach disconnected participants and connect them to the conference. You set this parameter in the <i>Options</i> menu <i>Communication</i> option. Once the participant connects to the conference, the number of retries is set to 0.
<i>Media Member</i>			Identifies the participant's media types: Audio and Data.
<i>Channels #</i>			Identifies the number of channels that are used for connecting this participant. Note: This parameter is not displayed for H.323 participants.
<i>Aggregation</i>			Displays the aggregation method of the channels that are used for connecting this participant: H.221, Bonding or Multi Rate. Note: This parameter is not displayed for H.323 participants.
<i>ID</i>			The participant ID as assigned by the system.
<i>Sync Loss Count</i>			For ISDN/ATM/MPI participants, indicates the general synchronization status. R indicates the endpoint (remote) status while L indicates the MCU status. A dash “-” indicates that there is no sync loss problem, while numbers indicate the number of times that the sync loss problem occurred at the remote or the local site.

Table 3-2: On Going Conference - Monitor Pane Columns (Continued)





Column Name	Icon	Indication	Description
<i>Disconnection Cause</i>			Displays the disconnection cause for a participant who is disconnected from the conference.
<i>Q&A Position</i>			Indicates the position held by the participant in the Q&A Queue: "1" being the next to speak, "2" being second up, and so on. This information is cleared when the participant begins to speak.
<i>Q&A Waiting Time</i>			Displays the total time spent by the participant waiting in the Q&A Queue. This information is cleared when the participant begins to speak.
<i>Last Vote</i>			During a voting session, displays the last vote that the selected participant entered (using DTMF code).
<i>Sub Conference Name</i>			Indicates whether the participant is in an Invite Session. The Invite option is available in Audio Only Conferences and enables the chairperson to dial-out (during an On Going Conference) to a participant inviting them to join. Displays "Invite" for the chairperson and the invited participant.

Additional Participant Statuses

Table 3-3 lists additional participant icons that are displayed when the participant is connected to an IVR-enabled conference. If none of these statuses occur, the *Status* column in the Status pane remains empty.

These statuses are primarily used in attended conferences.











Table 3-3: Participant in IVR-enabled Conference Status Icons

Icon	Description
	The participant is connected to the MCU and has entered the Entry Queue or the IVR queue.
	The participant was moved to the Operator Conference and is being assisted by the operator.
	The participant has requested the operator's assistance.
	The participant has requested the operator's assistance for the conference. Usually this means that the operator is requested to join the conference.
	The participant was placed on hold - is not currently taking part in any conference. While on hold, the participant hears background music.

Participant's Audio Status

Table 3-4 lists icons that indicate the current audio status of the participant.

Table 3-4: Participant Audio Status Icons

Icon	Description
 (Green)	The audio channel of the participant is connected.
 (Gray)	The audio channel is disconnected.
	This participant is the current conference speaker.
	This participant is the conference's Exclusive Speaker; in this mode, all other participants are automatically muted.
	The audio channel of the participant is muted by the participant (from the endpoint).
	The audio channel of the participant is muted by the participant and by the MCU.
	The audio channel of the participant is muted by the operator.
	The audio channel of the participant is muted by the participant and the operator.
	The audio channel of the participant is muted by the operator and the MCU.
	The audio channel of the participant is automatically muted by the MCU. (Exclusive Speaker mode).
	The audio channel of the participant is muted by the participant, operator and the MCU.

Monitor Filter

You can view only participants who have connection problems or require the operator's assistance. Participants may need your assistance when they are unable to connect to the conference, when manual dial-out is selected for a conference, when they have requested help, placed on hold, when their line is noisy, or when waiting in the Q&A Queue.

To display only the filtered participants in the Monitor pane:

1. Expand the *On Going Conferences* list.
2. Right-click the icon of the conference whose participants you want to monitor, and then click **Monitor Filter**.

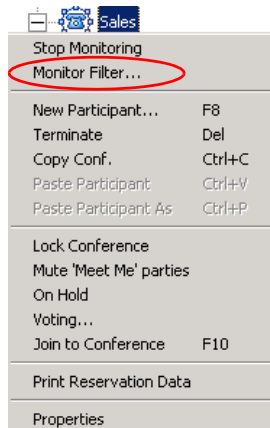

The *Participant Monitoring Filter* dialog box opens.

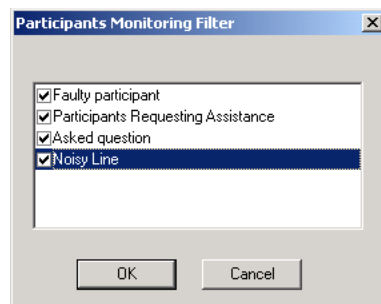

By default, all check boxes are selected to monitor all participants who require the operator’s attention. Clear the check boxes to indicate the participant statuses that you do not want to monitor. You can request to monitor any or all options.

The following statuses may be monitored:

Table 3-5: Monitored Participant Statuses

Filtering Option	Description
<i>Faulty Participant</i>	Participant who has problems connecting to the conference or who is using a noisy line.
<i>Need Assistance Participant</i>	Participant who has requested the operator’s assistance and has yet to be assisted by the operator. In Attended conferences, this option also includes the participants who have to wait for the operator’s assistance to connect to the conference.
<i>Asked Question</i>	Participants who are waiting in the Q&A queue.
<i>Noisy Line</i>	Participants whose audio channel is detected as noisy. The system uses a special algorithm to identify the endpoints that add background noise to the conference. Noise on a line can be caused by a variety of sources ranging from background noise, faulty equipment and noises emanating from the line itself. Note: The Noisy Line Detection feature is enabled/disabled in the “system.cfg” by defining the detection sensitivity. For more details on this feature, see “Noisy Line Detection Mechanism and Automatic Muting” on page 3-22.

Automatic Monitoring of Conferences

In addition to the filtering feature, you can configure the system to automatically monitor all the conferences according to the last Monitoring Filter that was set for any conference in the MGC Manager. When this feature is enabled, the system automatically displays all the conferences and all the participants that require the operator's attention to the *Monitor* pane in the MGC Manager main window.

To toggle between automatic and manual monitoring:

- On the *Options* menu, click **Monitor All** to activate automatic monitoring.

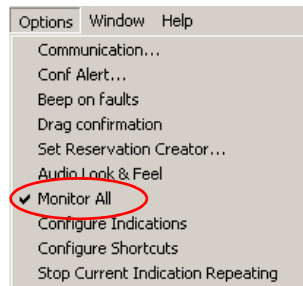

A check mark next to *Monitor All* indicates that the option is activated. Each click of the *Monitor All* option enables or disables this option.

Secure Conference Mode



The Secure mode locks the conference and prevents participants and operators, from joining the conference. A secured conference cannot be monitored or controlled in any way. However, operators can terminate the conference even when the conference is in this mode. While the conference is in the Secure mode, the operator cannot view the participants list or any other conference properties.

The conference chairpersons can enable or disable the Secure mode from their DTMF input device (touch-tone telephone or the endpoint's remote control), using the appropriate DTMF code (#70). During the secure conference, the chairperson and participants can perform various operations,

such as voting, question and answer sessions, via their DTMF input device using the appropriate DTMF codes. However, because of the mode, these operations or status changes are not displayed in the MGC Manager *Monitor* pane. Only conference statuses are indicated by special Secure mode icons.

Table 3-6 lists the icons that indicate the statuses of a Secure Audio Only conference.

Table 3-6: Secure Conference Status Icons

Icon	Indication	Description
	<i>Secure conference</i>	The audio only On Going Conference is in the Secure mode; the conference properties and the participants' list are hidden.
	<i>Faulty secure conference</i>	An exclamation point appears next to the secure conference icon when one of the following statuses occurs: <i>Empty, Single Party, Not Full, Faulty Connection, Resource Deficiency</i> and <i>Bad Resources</i> . For a detailed description of these statuses, see <i>Table 3-2 on page 3-7</i> . Note: Due to the locked nature of conference, no action can be taken to resolve these problems.
	<i>End-of-conference alert for Secure conference</i>	The secure conference is about to end.

Audio Tones

While defining the conference parameters, you can enable any of the audio tones (*Entry* tone, *Exit* tone, and *End of Conference Alert* tone) to be heard during an On Going Conference. If Roll Call is enabled for the conference, the audio tones are replaced with an appropriate message.

- **Exit Tone** - is played when a participant disconnects from the conference. All the connected participants hear this tone.
If Roll Call is enabled, the system announces the self-recorded name of the participant leaving the conference.
- **Entry Tone** - is played when a participant connects to the conference. This tone is heard by all the conference participants currently connected to the conference (but not by the connecting participant).
If Roll Call is enabled, the system announces the self-recorded name of the participant connecting to the conference.
- **End Time Alert Tone x Min** - the end of conference reminder is played once to all the connected participants, x minutes before the end of the conference. The x value is defined during the conference setup.
If Roll Call is enabled, the system plays the special audio message: "The conference is about to end".

Noisy Line Detection Mechanism and Automatic Muting

Noisy Line Detection Mechanism analyzes the participant’s line signal in order to detect a noisy line and notify the operator. Noise on a participant’s line can be caused by background noise, faulty equipment and noises emanating from the line itself. Noisy Line Detection is enabled and disabled on MCU level in the “system.cfg” by defining the detection sensitivity.

For more details, see the *MGC Administrators Guide*, Chapter 5.

During an On Going Conference, you can monitor noisy participant lines by selecting the *Noisy Line* monitor filter. See “Monitor Filter” on page 3-17

When the *Noisy Line* filter is enabled, the indicating icon  appears in the *Connection* column if a noisy line is detected by the system.

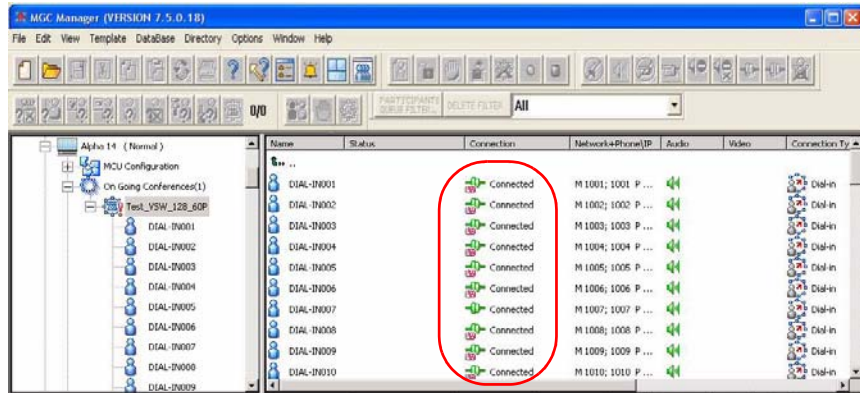

In addition, you can enable the *SilenceIT* option to automatically mute the audio participants who are identified as having a noisy line. SilenceIT uses an algorithm that detects continued background music or other noise that is not in the range of human speech. SilenceIT can be applied to Audio participants in Audio Only and Video conferences. This feature is enabled for conferences with IVR Service, during the conference setup/reservation stage, using the *Conference Properties - Settings* tab option.

For a detailed description, see Chapter 6, “Using SilenceIT” on page 6-6.

Participants Queue

This window lists participants who are waiting for the operator's assistance. It provides tools for managing participants in attended conferences. For more details, see Chapter 7, "Attended Conferencing".

Conference Level Monitoring

In addition to the general conference information that appears in the *Status* and the *Monitor* tables, you can view the details of the conference current status and setup parameters, using the *Conference - Properties* dialog boxes. While checking the properties, you can also edit several parameters.

To view the parameters of an On Going Conference:

1. In the *Status* pane, *Browser* pane or *Monitor* pane, right-click the icon of the conference and then click **Properties**.

The *Conference Properties – General* dialog box opens.

The screenshot shows the "Polycom Properties (Product Management)" dialog box with the "General" tab selected. The "Participants" and "Ongoing State" tabs are also visible and circled in red. The dialog contains various configuration fields for a conference, including name, duration, passwords, and network settings.

In an On Going Conference, two new tabs appear in the *Conference Properties* dialog box that were not applicable during the conference definition:

- Scheduler
- On Going State

You can view the conference general parameters and, if remarks have been entered, review the remarks history.

2. Click the **Scheduler** tab to view the date and time at which the conference had started and to view the ending time that was scheduled for the conference.

The *Conference Properties - Scheduler* dialog box opens.

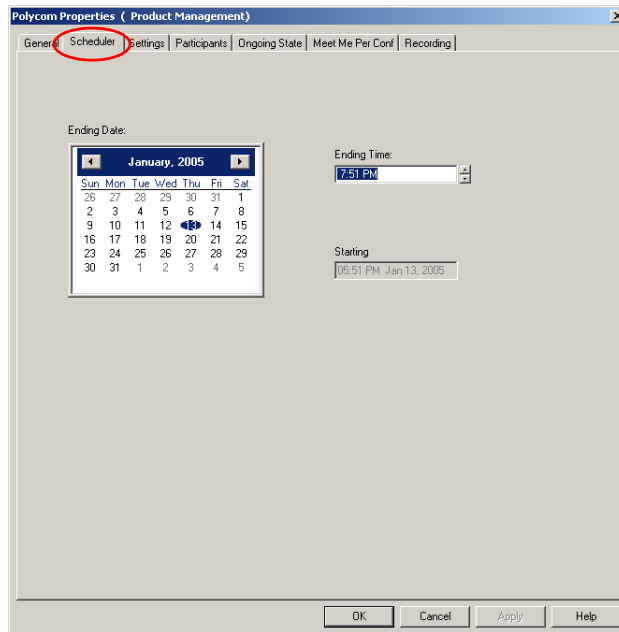

To shorten or extend the conference, you can adjust the conference ending date and time.

- Click the **Ongoing State** tab to view information about the conference status.

The *Conference Properties - Ongoing State* dialog box opens.

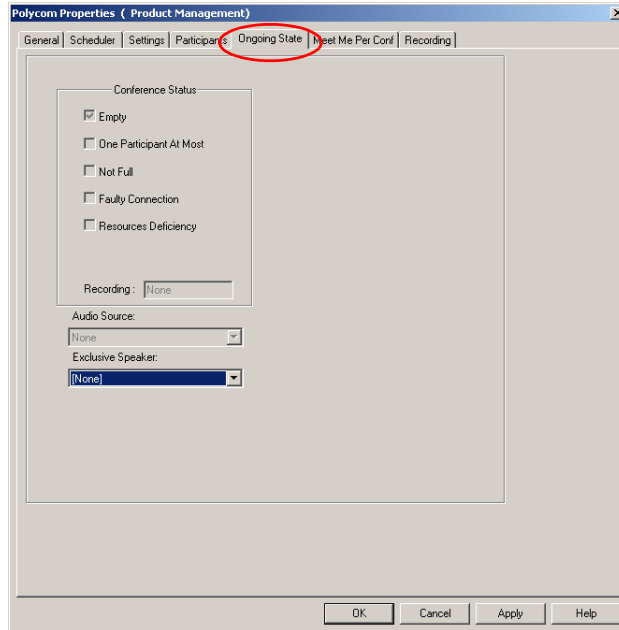

You can view the following parameters:

Table 3-7: *Conference Properties - Ongoing State*

Field/Option	Description
<i>Conference Status</i>	Displays the possible problem statuses of a conference. When a problem occurs during a conference, for example, a resource deficiency, the selected check box indicates that status. These statuses are also listed in the Connection column in the Monitor or the Status pane. For more information about the Monitor pane columns, see Table 3-2 on page 3-7.
<i>Recording</i>	If a recording port was defined for the conference, displays the name of the participant (port). The recording port is used to connect to a recording device.

Table 3-7: Conference Properties - Ongoing State (Continued)

Field/Option	Description
<i>Audio Source</i>	Displays the name of the current speaker.
<i>Exclusive Speaker</i>	Displays the name of the Exclusive Speaker who was designated for the conference.

4. Click the **Meet Me Per Conf** tab to view the ISDN dial-in number and which H323 prefix (if there are IP participants) was configured for the conference.















These numbers can be viewed in the Status pane. For details, see Table 3-1 on page 3-4.

5. Click **OK** or **Cancel** to exit the *On Going Conference Properties* dialog box. If you modify any parameters, click **Apply** in the relevant tab.

Participant Level Monitoring

In addition to the information that appears in the *Status* and the *Monitor* panes, you can also view the connection parameters and status of each of the conference participants. This feature is especially useful if there is a problem during the connection of the participant to the conference.

“Meet Me” dial-in participants (those who were not defined by the scheduler prior or during the conference) are automatically named by the system. These names are displayed next to the participant icon. The name is composed of the Entry Queue or On Going Conference name and a number.

 EQ Demo_869(000)	 Conn...	M 925192...	 Dial-in	0
 EQ Demo_871(000)	 Conn...	M 925192...	 Dial-in	0
 EQ Demo_872(000)	 Conn...	M 925192...	 Dial-in	0
 Sara	 (IVR)	 Conn...	9054631645	 Dial-out 0

Using the *Participant Properties* dialog box, you can verify the properties of the ISDN or VoIP participant who is connected to a conference. The *Identification*, *Advanced*, *Connection Info1*, *Connection Info2*, *Resource Details*, *Disconnection Cause*, *H.221* (or another used protocol) tabs are only displayed during an On Going Conference. These tabs contain information about the participant status while the conference is running and are used mainly to monitor the participant when a connection problem occurs.



For a detailed description of participant properties that can be modified during a conference, see Chapter 4, “Participant Level Operations” on page 4-5.

Monitoring ISDN/Telephone Participants

To view the ISDN participant's properties during a conference:

1. In the participants list in the *Status* pane, the *Browser* pane or the *Monitor* pane, double-click the participant icon.
 - Alternatively, right-click the appropriate participant icon, and then click **Properties**.
 - Alternatively, open the On Going *Conference Properties* dialog box and double click the participant's name in the *Participants* tab.

The *Participant's Properties - Identification* dialog box opens.

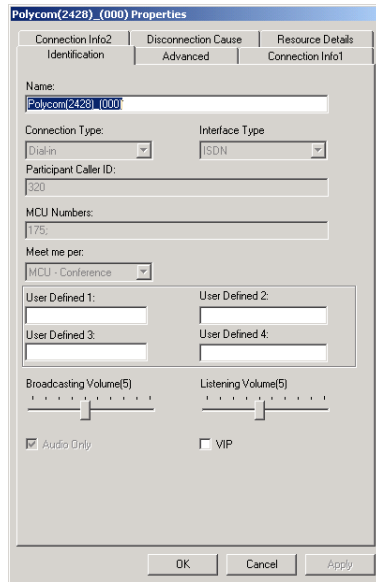

You can view the name and the dial-in numbers that were used by the participant to connect to the Entry Queue/Conference.

The following *Identification* parameters can be modified for a connected participant during an On Going Conference:

Table 3-8: ISDN Participant Properties - Identification

Field/Option	Description
<i>Name</i>	Indicates the participant's name.
<i>User Defined 1-4</i>	In either or all user defined fields, you can enter additional data about the participant, for example the email address, telephone number, or any other identifying information.
<i>Broadcasting Volume</i>	The volume at which the participant is heard by other participants. If not modified, the volume stays at the default level 5.
<i>Listening Volume</i>	The volume at which the participant hears other participants. If not modified, the volume stays at the default level 5.
<i>VIP</i>	Indicates whether the participant is defined as a VIP.

If required, the participant's Identification and Advanced parameters can be modified during an On Going Conference, but only if the participant is disconnected from the conference. For more details on the Identification and Advanced tabs, see Chapter 2, "ISDN/PSTN/T1-CAS Participant Definition" on page 2-51.

2. To obtain information regarding the participant's connection status, click the **Connection Info1** tab.

The *Participant Properties - Connection Info1* dialog box opens.

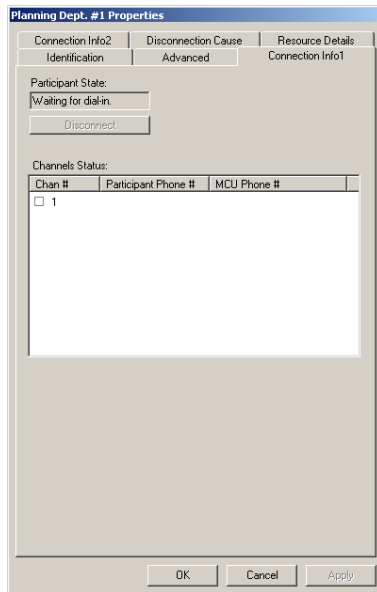

The following information is displayed for the connected participant:

Table 3-9: ISDN Participant Properties - Connection Info1

Field/Option	Description
<i>Participant State</i>	The current connection status of the participant. Note: This status is indicated in the <i>Monitor</i> and <i>Status</i> panes. For more details, see Table 3-2 on page 3-7.
<i>Disconnect/ Reconnect</i>	Depending on the current participant status in the On Going Conference, this button lets you disconnect or reconnect the participant.
<i>Channels Status</i>	The status of the participant's audio channel according to the following parameters: <ul style="list-style-type: none"> Channel – Indicates the connection status of the audio channel. A check mark next to the audio channel indicates that it is connected.

Table 3-9: ISDN Participant Properties - Connection Info1 (Continued)

Field/Option	Description
<i>Channels Status (cont.)</i>	<ul style="list-style-type: none"> • Participant Phone # – In a dial-in connection, indicates the participant's CLI (Calling Line Identification) as identified by the MCU. In a dial-out connection, indicates the participant's phone number dialed by the MCU. • MCU Phone # – In a dial-in connection, indicates the MCU number dialed by the participant. In a dial-out connection, indicates the CLI number of the MCU as seen by the participant. This number is entered in the <i>MCU Number</i> field in the <i>ISDN Network Service</i> configuration.

If required, modify the following parameters:

- disconnect the participant, by clicking the *Disconnect* button
3. To view general information regarding the participant connection and to mute or unmute the participant's audio channel, click the **Connection Info2** tab.

The *Participant Properties - Connection Info2* dialog box opens.

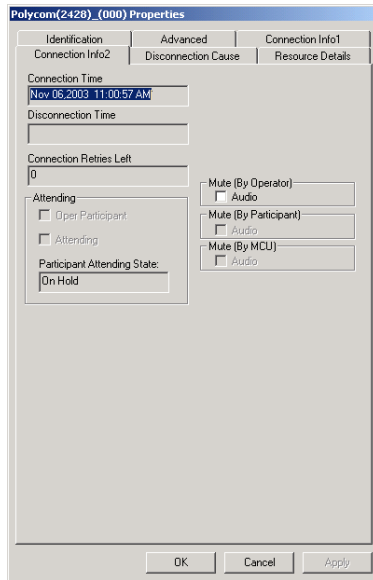

The following information is displayed for the connected participant:

Table 3-10: ISDN Participant Properties - Connection Info2

Field/Option	Description
<i>Connection Time</i>	The date and time the participant connected to the conference. Note: The time format is derived from the operating system's time format.
<i>Disconnection Time</i>	The date and time of participant's disconnection.
<i>Connection Retries Left</i>	The number of retries left for the system to connect the participant to the conference.

Table 3-10: ISDN Participant Properties - Connection Info2 (Continued)

Field/Option	Description
<i>Attending</i>	The participant or operator status in a conference with an assigned IVR Service. <ul style="list-style-type: none"> • Oper Participant – This option is checked when viewing the operator parameters. • Attending – This option is checked when the participant is in a Attended state.
<i>Participant Attending State</i>	The status of the Attended participant: <ul style="list-style-type: none"> • Attended – The participant is being assisted by the operator (in an Operator Conference) • On Hold – The participant was placed on hold and hears background music.
<i>Mute (By Operator)</i>	When checked, indicates that the participant's audio channel was muted by the operator.
<i>Mute (By Participant)</i>	When checked, indicates that the audio channel was muted by the participant.
<i>Mute (By MCU)</i>	When checked, indicates that the participant's audio channel was automatically muted by the MCU upon connection to the conference or when the Exclusive Speaker mode was enabled. Note: This option is activated when the <i>Mute Incoming Parties</i> option is checked in the <i>Conference Properties - Settings</i> dialog box.

If required, modify the following parameters:

- mute the participant by checking the *Mute (By Operator)* button.
4. To view the MCU resources used to handle the participant, click the **Resource Details** tab.

The *Participant Properties - Resource Details* dialog box opens.

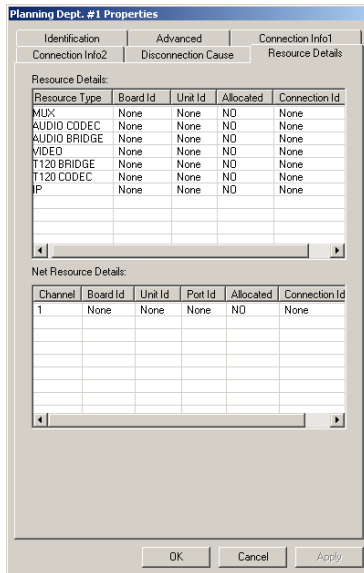

The following information is displayed for the connected participant:

Table 3-11: ISDN Participant Properties - Resource Details

Field/Option	Description
Resource Details	
	Displays information about MCU modules used to handle the participant. The following parameters are displayed:

Table 3-11: ISDN Participant Properties - Resource Details (Continued)

Field/Option	Description
<i>Resource Type</i>	The type of the conference resource installed in the MCU: <ul style="list-style-type: none"> • <i>MUX</i> - The MUX card. Not relevant to Audio Only participant. • <i>Audio Codec</i> - The audio encoding /decoding port. • <i>Audio Bridge</i> - The Audio Bridge that mixes the audio signal received from various ports. Applicable only to Video participants using the Standard Audio card to connect to the conference. • <i>T120 Codec</i> - Not relevant to Audio Only participant. • <i>T120 Bridge</i> - Not relevant to Audio Only participant. • <i>Video</i> - Not applicable to Audio Only. • <i>IP</i> - Applicable to H.323 and SIP participants.
<i>Board ID</i>	The number of the slot where the card containing the resource that is used to run the conference and handle the participant, is installed.
<i>Unit ID</i>	The unit number (on the card) used to handle the participant in the conference.
<i>Allocated</i>	Indicates whether the MCU resources listed in the <i>Resource Type</i> column are allocated to the conference.
<i>Connection ID</i>	The number identifying participant's connection.
Net Resources	
Displays information about the network interface module used to run the conference and handle the participant.	
<i>Channel</i>	The participant's channel number.
<i>Board ID</i>	The number of the slot in which the card containing the resource that is used to run the conference and handle the participant, is installed.
<i>Unit ID</i>	The span used to handle the participant in conference.
<i>Port ID</i>	The port number on the Network card allocated to the participant.

Table 3-11: ISDN Participant Properties - Resource Details (Continued)

Field/Option	Description
<i>Allocated</i>	Indicates whether the Network card installed in the MCU is used to run the conference.
<i>Connection ID</i>	The number identifying participant's connection.

5. If the participant is disconnected from the conference, click the **Disconnection Cause** tab to display the cause.

The *Participant Properties - Disconnection Cause* dialog box opens.

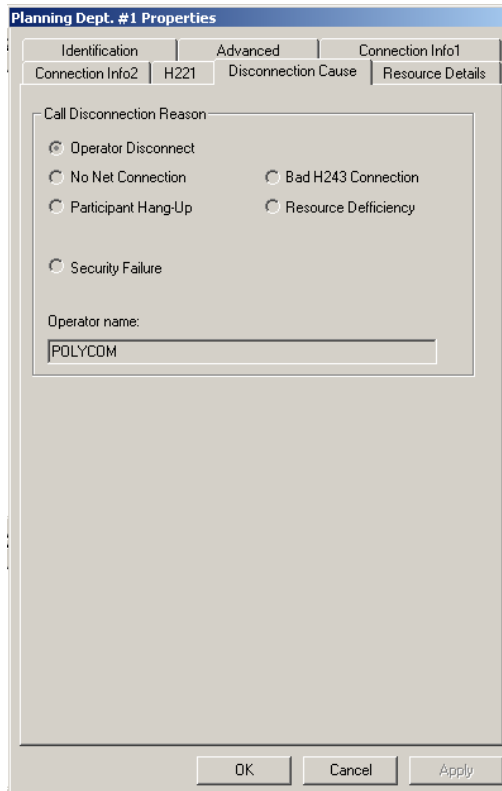

The following information is displayed for the disconnected participant:

Table 3-12: ISDN Participant Properties - Disconnection Cause

Field/Option	Description
<i>Call Disconnection Reason</i>	<p>Lists the reasons for participant's disconnection:</p> <ul style="list-style-type: none"> • Operator Disconnect – The participant was disconnected from the conference by the operator. • No Net Connection – Network channels could not be connected. This reason may occur when the telephone lines are unavailable or busy. • Participant Hang Up – The participant disconnected himself from the conference. • Bad H.243 Connection – Problems occurred with the connection protocol. • Resource Deficiency – Hardware resources (audio or network cards) are insufficient and cannot handle the conference. • Security Failure – Encryption related problem prevented the connection. Not relevant to ISDN Audio Only participant.
<i>Cause</i>	<p>Describes the cause of disconnection according to the category indicated in the <i>Call Disconnection Reason</i>. For example, when <i>Operator Disconnect</i> is selected, the name of the <i>Cause</i> field is changes to <i>Operator Name</i> and lists the name of the operator who disconnected the participant.</p>

Checking the Status of VoIP Participants

The various properties of a VoIP (H.323 or SIP) participant can be viewed using the same method used to display the ISDN participant properties.

In addition to the *Identification, Advanced, Connection Info1, Connection Info2, Disconnection Cause and Resource Details*, the *H.245* tab is included for H.323 participants and the corresponding *SDP* tab is included for SIP participants. These tabs contain information that is relevant only to the participant status while the conference is running, and are used mainly to monitor the participant's status when connection problems occur.



In *Audio Look and Feel* you can monitor video participants as well as Audio Only.

To monitor the status of VoIP participant:

1. In the *Monitor, Status or Browser* pane, right-click the participant icon, and then click **Properties**.

The *Participant's Properties - Identification* dialog box appears,

Audio party Properties

Connection Info2 | **H245** | Disconnection Cause | Resource Details
 Identification | Advanced | Connection Info1

Name: Audio party

Connection Type: Dial-out | **Interface Type: H323**

Participant IP: 172 . 22 . 172 . 63 | Signaling Port: 1720

Alias Name: | Alias Type: H323 ID

Extension/Identifier String:

User Defined 1: | User Defined 2: |
 User Defined 3: | User Defined 4: |

Broadcasting Volume(5) | Listening Volume(5)

Audio Only | VIP

OK Cancel Apply

Connected H.323 participant - Identification tab

Planning Dept. #1 Properties

Connection Info1 | **SDP** | Disconnection Cause | Resource Details
 Identification | Advanced | Connection Info1

Name: Planning Dept. #1

Connection Type: Dial-in | **Interface Type: SIP**

Participant IP: 255 . 255 . 255 . 255 | Signaling Port: 5060

SIP Address:

Address Type: SIP URI | Extension/Identifier String:

User Defined 1: Planning Dept. head | User Defined 2: local office |
 User Defined 3: | User Defined 4: |

Broadcasting Volume(5) | Listening Volume(5)

Audio Only | VIP

OK Cancel Apply

Connected SIP participant - Identification tab

The following *Identification* parameters can be modified for a connected participant:

Table 3-13: VoIP Participant Properties - Identification

Field/Option	Description
<i>Name</i>	Indicates the participant's name.
<i>User Defined 1-4</i>	Place to enter additional data about the participant, for example the email address, telephone number, or any other identifying information.
<i>Broadcasting Volume</i>	The volume at which the participant is heard by other participants. If not modified, the volume stays at the default level 5.
<i>Listening Volume</i>	The volume at which the participant hears other participants. If not modified, the volume stays at the default level 5.
<i>VIP</i>	Indicates whether the participant is defined as a VIP.

If required, modify the following parameters:

- change the participants name by entering a new name in the *Name* field
- enter information in any or all *User Defined* fields
- adjust the broadcasting / listening volume using the slider
- change the VIP status by selecting or clearing the VIP check box



For more information on the Identification and Advanced parameters that can be modified during an On Going Conference only if the participant is disconnected, see Chapter 4, "Changing the Disconnected Participant's Properties" on page 4-10. For description of the IP participant definition, see Chapter 2, "Defining New On Going Audio Conferences" on page 2-14.

2. Click the **Connection Info1** tab.
The *Participant Properties - Connection Info1* dialog box opens.
3. To view detailed connection information per channel, expand the dialog box, by clicking **Channel Info**.

The *Channel Info* pane opens.

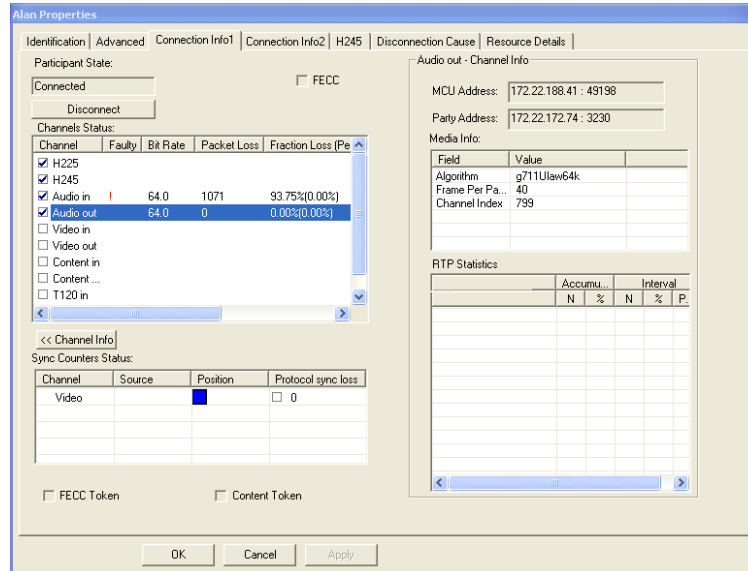

The following information is displayed in the expanded tab:

Table 3-14: VoIP Participant Properties - Connection Info1

Field/Option	Description
<i>Participant State</i>	The current connection status of the participant. Note: This status is indicated in the <i>Monitor</i> and <i>Status</i> panes, see "Table 3-2 describes the Monitor pane columns." on page 3-7.
<i>Disconnect/Reconnect</i>	Use the button do reconnect a disconnected participant or to disconnect a connected one.
<i>Channels Status</i>	The following parameters are displayed in this table: Channel; Faulty; Bit Rate; Fraction Loss (Peak); Jitter (Peak); # Packets; Latency. The checked boxes indicate the multimedia channels (Audio and Data) that are connected.
<i>Sync Counters Status</i>	The following parameters are displayed in this table: Channel; Source; Position; Protocol Sync Loss.

Table 3-14: VoIP Participant Properties - Connection Info1 (Continued)

Field/Option	Description
<i>FECC Token</i>	Not relevant in Audio Only.
<i>Content Token</i>	Not relevant in Audio Only.
<i>Channel Info</i>	Displays detailed information about a selected channel. You can click this button to expand (>>) or to collapse (<<) the additional <i>Channel Info</i> pane. In the <i>Channel Status</i> table <i>Channel</i> column, select a channel to monitor and click this button. Note: The displayed information varies according to the properties of the selected channel.

If required, modify the following parameters:

— disconnect the connected participant.

4. Click the **Connection Info2** tab.

The *Participant Properties - Connection Info2* dialog box opens.

The screenshot shows the 'Audio party Properties' dialog box with the 'Connection Info2' tab selected. The dialog is divided into several sections:

- Identification:** Includes tabs for Identification, Advanced, and Connection Info1. Sub-tabs include Connection Info2, H245, Disconnection Cause, and Resource Details.
- Connection Time:** Jan 23, 2005 16:27:05 PM
- Disconnection Time:** (Empty field)
- Connection Retries Left:** 0
- Attending:**
 - Oper Participant
 - Attending
 - Participant Attending State: (Empty field)
- Gatekeeper Status:**
 - Gatekeeper State:
 - AFQ
 - Admitted
 - DRQ
 - None
 - Gatekeeper routed
- Mute Controls (Right Side):**
 - Mute (By Operator) - **Circled in red**
 - Audio
 - Mute (By Participant)
 - Audio
 - Mute (By MCU)
 - Audio
- Requested Bandwidth:** 128 KBPS
- Allocated:** 128 KBPS
- Request Info Interval:** 0 Sec

Buttons at the bottom: OK, Cancel, Apply.

The following information is displayed for a connected participant:

Table 3-15: VoIP Participant Properties - Connection Info2

Field/Option	Description
<i>Connection Time</i>	The date and time the participant connected to the conference.
<i>Disconnection Time</i>	The date and time the participant was disconnected from the conference.
<i>Connection Retries Left</i>	The number of retries left for the system to connect the participant to the conference.
<i>Mute (By Operator)</i>	If checked, indicates the participant's audio channel was muted by the operator during the conference. To unmute the participant, clear this check box.
<i>Mute (By Participant)</i>	Indicates if the Audio channel has been muted by the participant.
<i>Mute (By MCU)</i>	Indicates if the Audio channel has been muted by the MCU.
<i>Gatekeeper Status</i>	Indicates the status of the participant's registration with the Gatekeeper and the bandwidth allocated to the participant. <ul style="list-style-type: none"> • ARQ – (Admission Request) Indicates that the participant has requested the gatekeeper to allocate the required bandwidth on the LAN. • Admitted – Indicates that the gatekeeper has allocated the required bandwidth to the participant. • DRQ – (Disengage Request) The endpoint informs the gatekeeper that the connection to the conference is terminated and requests to disconnect the call and free the resources. • None – Indicates that there is no connection to the gatekeeper.
<i>Requested Bandwidth</i>	The bandwidth allocation requested by the participant from the gatekeeper in the <i>Admission Request</i> , measured in Kbps.

Table 3-15: VoIP Participant Properties - Connection Info2 (Continued)

Field/Option	Description
<i>Allocated</i>	The actual bandwidth allocated to the participant by the gatekeeper when the participant is admitted to the conference, measured in Kbps.
<i>Requested Info Interval</i>	Some gatekeepers request an <i>alive and well</i> message from the endpoint, to keep the resources allocated to it. This field indicates the frequency (in Kbps) in which this message is sent to the gatekeeper.
<i>Gatekeeper Routed</i>	Indicates whether the participant's call is routed via the gatekeeper.

If required, modify the following parameters:

- Mute or unmute the participant
5. Click the **H.245**, or SDP tab for SIP participants, tab to view the capabilities exchange results between the participant (endpoint) and the conference (MCU). It is a monitoring-only tab.

The *Participant Properties – H245* tab opens.

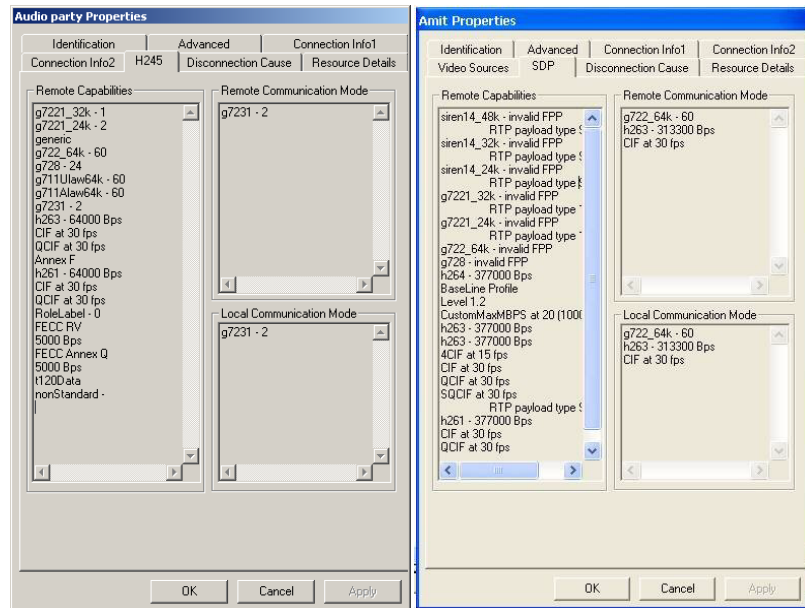

The following information is displayed for a connected participant:

Table 3-16: VoIP Participant Properties - H245

Field/Option	Description
<i>Remote Capabilities</i>	Lists the resources used by the connected endpoint (participant).
<i>Remote Communication Mode</i>	Lists the protocols used by the connected endpoint (participant).
<i>Local Communication Mode</i>	Lists the protocols used by the MCU.

In this tab, you cannot modify information.

6. Click the **Resource Details** tab to view the MCU resources allocated to the participant.

The *Participant Properties – Resource Details* dialog box opens.

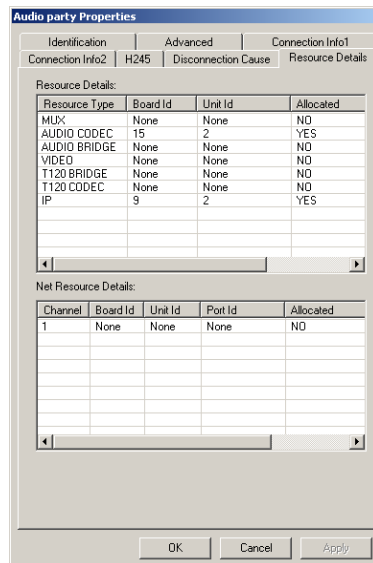

The displayed information is the same as for ISDN participant, see Table 3-11, ISDN Participant Properties - Resource Details, page 3-34.

7. If the participant has been disconnected, click the **Disconnection Cause** tab to view the reasons for the participant's inability to connect to the conference.

The *H.323 Participant Properties - Disconnection Cause* tab opens.

The screenshot shows the 'Alan Properties' dialog box with the 'Disconnection Cause' tab selected. The 'Call Disconnection Reason' section is expanded, and the 'Operator Disconnect' radio button is selected. Below this, the 'Operator name' text box contains the text 'POLYCOM'. The 'Video Disconnection Reason (Secondary)' section is also expanded, showing several radio button options, none of which are selected. At the bottom of the dialog, there are 'OK', 'Cancel', and 'Apply' buttons.

The following information is displayed for the disconnected participant:

Table 3-17: VoIP Participant Properties - Disconnection Cause

Field/Option	Description
<i>Call Disconnection Reason</i>	<p><i>Gatekeeper Failure</i> and <i>H323 Failure</i> disconnection cause categories are exclusive to H.323 participants. All other statuses are identical to ISDN participants and are described in Table 3-12, "ISDN Participant Properties - Disconnection Cause," on page 3-37.</p> <ul style="list-style-type: none"> <i>Gatekeeper Failure</i> - Participant's failure to connect to the conference is caused by the gatekeeper. <i>H323 Failure</i> - Participant's failure to connect to the conference is caused by the MCU H.323 card.
<i>Cause</i>	Describes the cause of disconnection according to the category indicated in the <i>Call Disconnection Reason</i> .

Table 3-17: VoIP Participant Properties - Disconnection Cause (Continued)

Field/Option	Description
<i>Video Disconnection Reason</i>	(0) Lists the disconnection cause categories for video conferences that you can monitor in <i>Audio Look and Feel</i> .
<i>Cause</i>	Describes the cause of disconnection according to the category indicated in the <i>Video Disconnection Reason</i> .
<i>Possible Solution</i>	Indicates a possible course of action to enable participant's reconnection (video conferences only).

Operations Performed During On Going Conferences

During an On Going Conference, the MGC Manager operator can perform many management tasks at the conference level or at the participant level.

Operations at the participant level affect individual connections, while those at the conference level affect several or all participants of the conference.

Operators can terminate a conference before the originally scheduled ending or extend its duration. Alternatively, they can disconnect an individual participant while the conference is in progress or temporarily mute the transmission to enable other participants to hold a private discussion.

Operators can establish an operator-controlled dial-out connection during the conference and add a new participants during session.

Some conference management tasks can also be performed by chairpersons from their endpoint, using DTMF codes or the WebCommander application.

This chapter describes the activities and options available to the operator or the chairperson during an On Going Conference.

Management Functions Overview

The MGC Manager operator performs different roles during attended and unattended conferences.

Attended Conferences

On Going attended conferences require an active Operator conference to run on the same MCU as the attended conference. In attended conferences, participants accessing an Entry Queue or an IVR queue are moved to the Participants Queue where they wait for the operator to assist them. The operator's role during this stage is to use the *Participants Queue* management tools to move the participants from the Participants Queue to the destination conference. During an On Going Conference, the operator can take part in the conference and perform various tasks, for example assist participants privately; conduct a voting session, manage a Question-and Answer session, place participants on hold, and lock the conference to dial-in participants. For a detailed description of Attended Conferencing, see Chapter 7, "Attended Conferencing" on page 7-1.

Unattended Conferences

In unattended conferences, participants use DTMF codes in response to menu-driven voice prompts and in this way are guided to the conference. Unless there is a problem in the connection or the participant did not enter the correct conference Numeric ID or password, operator intervention is not required. In unattended conferences the operator usually leaves the management of the conference to a designated participant, usually the chairperson/meeting organizer. The conference chairperson can perform certain operator's functions, such as start a voting session, control the Q&A session, mute incoming parties, place the conference on hold and lock or unlock the conference.

All chairperson functions can be performed either via the WebCommander interface or using DTMF codes from the participant's endpoint.

Participant and Conference Level Operations

Operators can perform functions on conferences that affect individual participants or can affect the conference on the whole.

Participant Level Operations

The following operator actions are performed at the participant level:

- Make dial-out connections
- Change the participant connection type (dial-in/dial-out)
- Disconnect and reconnect participants
- Name undefined dial-in participants
- Change the properties of a disconnected participant
- Designate a participant as an Exclusive Speaker
- Designate a participant as a VIP
- Control the participant's listening and broadcasting volume
- Mute or un-mute a participant
- Modify user defined parameters for the participant (MGC Manager only)
- Move a participant to an operator conference (attended conference only)
- Move a participant to the home conference (attended conference only)
- Place a participant on-hold (attended conference only)

For management operations performed during an Attended conference, see Chapter 7, "Attended Conferencing".

Conference Level Operations

The following operator actions are performed at the conference level:

- Add new participants
- Mute dial-in participants upon their connection to the conference
- Add remarks during session
- Lock and unlock a conference
- Control Question-and-Answer sessions
- Conduct Voting sessions
- Place a conference on hold
- Modify the conference general parameters (MGC Manager only)

- Change the conference duration while in session
- End a conference before its scheduled termination time
- Reschedule a conference reservation
- Send conference details to a file, printer or clipboard

Participant Level Operations

Making Dial-Out Connections

When the *Dial-Out Manually* option is selected for the conference, the operator has to manually connect dial-out participants to the conference. This can be necessary when the connected participant is accidentally disconnected from the conference.

To establish a dial-out connection:

- Right-click the disconnected participant icon, and then click **Connect Participant**.

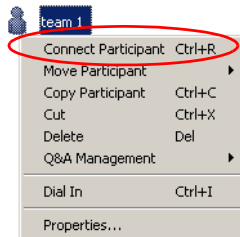

During the connection process, the participant's status and icon, which is displayed in the *Connection* column, changes from *Standby* to *Connecting*. When the connection is established, the participant's status and icon changes to *Connected*.

Name	Status	Connection
...		
Duke		Connected
Lynne		Disconnected



- Use this procedure to reconnect participants who were previously disconnected from the conference or failed to connect to the conference.
- If you have difficulties connecting dial-out ISDN participants, ensure that the specific switch used for the connection does not require the addition of the pound key (#) at the end of the dial string. If it does, modify the properties of the disconnected participant and then try again to connect.

For a description of all the participants' connection status indications and icons, see Table 3-2: On Going Conference - Monitor Pane Columns, page 3-7.

Changing Participant Connection Types (Dial-In/Dial-Out)

You can change the connection type used by the participant to connect to the conference. For example, when the participant cannot dial-in and you want the MCU to dial-out to the participant, you can toggle between the dial-in and dial-out connection type.



- The *Connection Type* parameter can be changed only when the participant is disconnected from the conference and both dial-in and dial-out parameters are defined in the *Participant Properties - Identification* dialog box.
- If the dial-in phone numbers are not defined for the participant when switching to dial-in and the Meet Me Per option is set to MCU - conference, the system automatically allocates the appropriate phone numbers from the list of dial-in numbers defined in the Network Service that was selected for participants.
- If the Meet Me Per option is set to *Party* or *Channel*, and no CLI number is defined for the participant, the system will reject the participant's call.

To toggle between Connection Types:

1. In the *Monitor* pane, *Status* pane or *Browser* pane, list the participants defined for the conference.
2. Right-click the participant's icon whose connection type needs to be changed, and then click **Dial In** or **Dial Out** (depending on the participant's current definition).

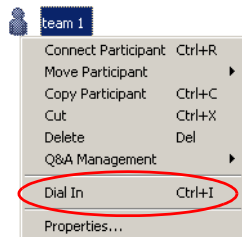

The system toggles between dial-in and dial-out depending on the current participant connection type.

Disconnecting Participants from Conferences

When participants do not need to continue with the conference, you can remove them from the conference by:

- Disconnecting
- Deleting

When you disconnect a participant, resources remain allocated to that participant and the defined properties are retained by the system's memory, therefore you can easily reconnect the participant if necessary. This is useful when participants want to discontinue the conference temporarily and return to it later.

On the other hand, deleting a participant completely removes all participant information from the conference and releases the resources that were allocated to that participant, making them available for other participants. However, to reconnect a participant who was deleted from the conference, you must define the parameters again as you would do for a new participant.

To disconnect a participant:

1. In the *Monitor* pane, *Status* pane or *Browser* pane, list the participants connected to the conference.
2. Right-click the icon of the participant to disconnect, and then click **Disconnect Participant**.

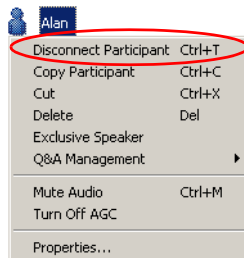

The participant is disconnected from the conference but the resources remain allocated in case the participant is reconnected. The participant status and icon change to *Disconnected* in the *Connection* column.



To reconnect a disconnected participant, right-click the participant icon, and then click **Connect Participant**.

To delete a participant:

1. Right-click the icon of the participant to delete, and then click **Delete**, or press the key.

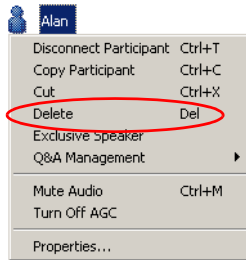

A message appears, requesting you to confirm the deletion.

2. Click **Yes** to delete the selected participant.

The participant's name disappears from the participants list in the *Monitor*, *Status* and *Browser* panes. To reconnect the participant who has been deleted from a conference, you must add this participant to the conference as a new participant.

Naming Undefined Dial-in Participants

The MGC Manager automatically assigns names to all dial-in participants who were not defined prior to the start of the conference (undefined participants) once they connect to the conference. This default name is derived from the conference name and a sequential number.

You can edit the automatically assigned name to correctly display it in the *Monitor* and *Status* panes. The name change is also updated in the Call Detail Record (CDR) which is used for billing. Usually the operator changes the name while attending the participant (in the Operator conference).

You can also change participants names when they are waiting in the Entry Queue or when they are connected to the conference.

To name a “Meet Me” dial-in participant:

1. List the participants in the Operator conference, in an On Going Conference or in the Participants Queue.

- Right-click the participant icon, and then click **Properties**.

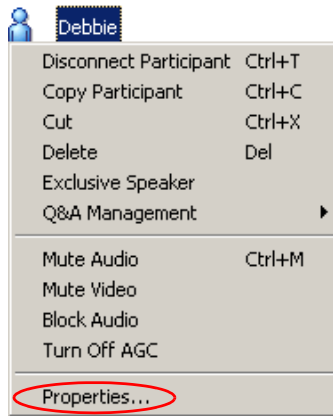

The *Participant Properties - Identification* dialog box opens.

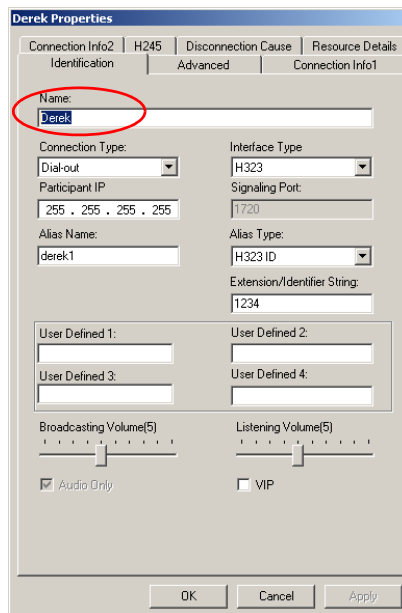

- In the *Name* field, type the participant's new name.
- Click **OK**.

The participant name is updated in the *Browser, Monitor* and *Status* panes. This name will also be saved to the CDR (Call Detail Record) file.

Changing the Disconnected Participant's Properties

You can change several properties of a disconnected participant, for example before reconnecting that participant. These modifications can be performed in the *Participant Properties* dialog box.

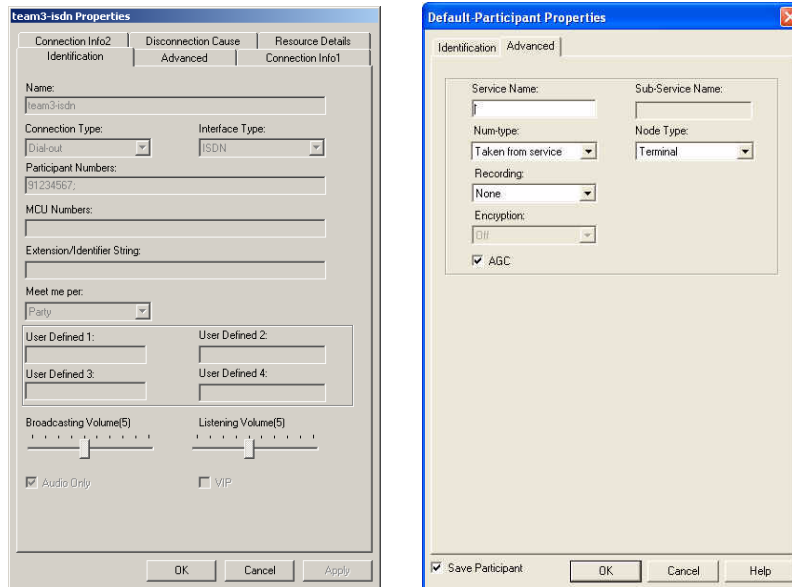

- **Name** - Modify the participant's name to correctly display it in the *Monitor* and *Status* panes. For more details, see Chapter 2, "Defining Participant Properties" on page 2-49.
- **Connection Type** - Alter the participant connection from dial-in to dial-out or vice versa.
- **Phone Number or IP address** - Change the participant's dial-in/dial-out phone number or IP dress as required.
- **Interface Type** - Change the participant's interface (and protocol), provided that the endpoint supports both ISDN and IP.
- **VIP Status** - Change the participant' status from or to VIP.
- **Service Type** - Change the name of the Network Service that the participant is using to connect to the conference.

- **AGC** - disable AGC when required (enabled is the default).



You can change encryption settings during an On Going Conference only when the participant is disconnected.

Moving a Participant from one Conference to Another

A participant can be moved from one On Going Conference to another on the same MCU using either one of two methods: interactively (drag and drop), or from the participant's right-click menu.

You can move individual participants, or you can move several participants at the same time by using standard Windows conventions to select the participants to move.

To interactively move participants from one conference to another:

1. Expand the On Going Conferences list in the *Browser* pane, to display the home conference icon and the destination conference icon.
2. Drag the icon of participant from the home conference and drop it on the target conference icon.

To move participants using the right-click menu:

1. In the *Browser* pane, expand the participant list of the source conference.

2. Right-click the icon of the participant to move, click **Move Participant** to open the list of active conferences, and then click the name of the destination conference.

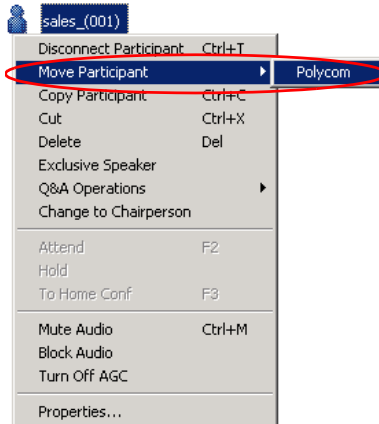

The participant is transferred to the selected destination conference.

Designating an Exclusive Speaker

During On Going Conferences, you can designate one participant as the conference lecturer/speaker, while all other participants are automatically muted so as not to interrupt the lecture.

Alternatively, chairpersons can designate themselves as the Exclusive Speaker for the conference using the appropriate DTMF code (the default code is *5) or cancel the Exclusive Speaker mode (default DTMF code is #5).

The operator can unmute participants who were muted by the MCU, or cancel the Exclusive Speaker mode. The chairperson can only cancel the Exclusive Speaker mode.



You can manually add special DTMF codes to enable participants to override the Exclusive Speaker Mute mode. For more details, see Table 4-4 on page 4-62.



When the Exclusive Speaker mode is cancelled, the audio channel of all muted participants is automatically restored.

To designate or cancel a participant as the Exclusive Speaker:

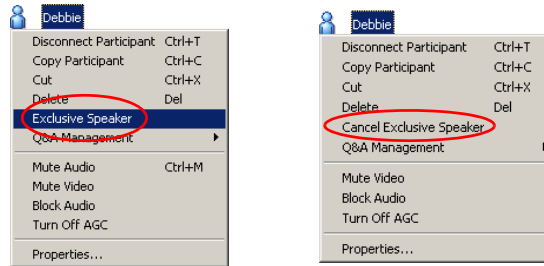
- In the *Browser*, *Monitor* or *Status* panes, right-click the Participant icon, and then click **Exclusive Speaker** or **Cancel Exclusive Speaker**.



In the Exclusive Speaker mode, the selected participant becomes the conference speaker while all the other participants are automatically muted by the system.

The Exclusive Speaker icon  is displayed in the *Audio* column in the *Monitor* and *Status* pane. The *Muted by MCU* icon  is displayed in the *Audio* column of all other participants.

Changing Participant's Status to Conference Chairperson

During On Going Conferences, operators can designate a participant to function as the conference chairperson. The chairperson can perform various operations during the conference, such as lock or unlock the conference to dial-in participants, initiate a voting session, become the conference exclusive speaker while muting all other participants, and more.

This option is enabled in conferences in which the *Conference Chairperson* option is **enabled** in the assigned IVR Service.

To change a participant's status to conference chairperson:

- In the *Browser*, *Monitor* or *Status* pane, right-click the participant's icon and then click **Change to Chairperson**.



The selected participant becomes the conference chairperson, and the icon changes accordingly.

To revert the chairperson's status to regular participant:

- In the *Monitor* or *Status* pane, right-click the chairperson's icon and then click **Change to Regular Participant**.

This feature can also be activated by the participant using DTMF codes.

Designating a VIP Participant

During an On Going Conference, you can designate a participant or a chairperson who requires special attention, as a VIP. The VIP status does not change the role of the participant. You can assign this status when defining a new participant or a participant who is currently taking part in an On Going Conference. You can change the VIP status of participants during a conference.

VIP participants are indicated with the *VIP*  icon.

To designate a participant as a VIP:

1. In the *Browser, Monitor* or *Status* pane, right-click the participant's icon and then click **Properties**.

The *Participant's Properties - Identification* dialog box opens.

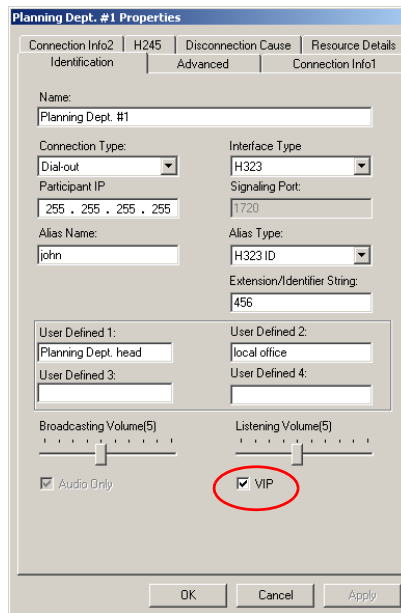

The screenshot shows the 'Planning Dept. #1 Properties' dialog box with the 'Identification' tab selected. The dialog contains several fields and controls:

- Name:** Planning Dept. #1
- Connection Type:** Dial-out (dropdown)
- Participant IP:** 255 . 255 . 255 . 255
- Interface Type:** H323 (dropdown)
- Signaling Port:** 1720
- Alias Name:** john
- Alias Type:** H323 ID (dropdown)
- Extension/Identifier String:** 456
- User Defined 1:** Planning Dept. head
- User Defined 2:** local office
- User Defined 3:** (empty)
- User Defined 4:** (empty)
- Broadcasting Volume(5):** (slider)
- Listening Volume(5):** (slider)
- Audio Only
- VIP (circled in red)

Buttons at the bottom: OK, Cancel, Apply.

2. Select the **VIP** check box to assign the new status to the participant, and then click **OK**.

The selected participant becomes a VIP in the On Going conference. The other participant's properties are unchanged.

To revert the VIP status to regular participant:

- In the *Participant's Properties - Identification* dialog box, clear the VIP check box, and then click **OK**.
The selected participant's VIP status is revoked.

Adjusting Participant's Broadcasting and Listening Volume

The broadcasting and listening volume of the participant's audio transmission can be changed during an On Going Conference. This operation is applicable to all interface types.

To adjust the broadcasting and listening volume for the participant:

1. In the *Browser, Monitor* or *Status* panes, right-click the participant's icon, and then click **Properties**. Alternatively, double-click the participant icon.

The *Participant Properties - Identification* dialog box opens.

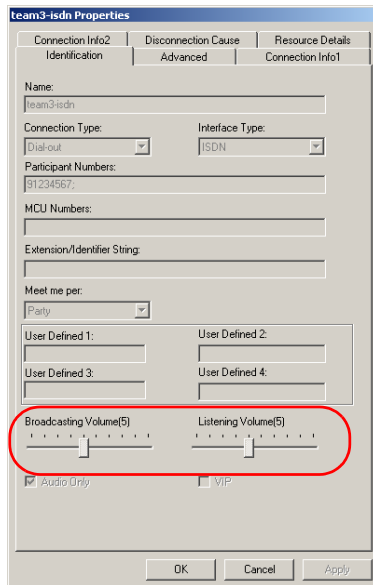

ISDN/Telephone Participant Identification Properties

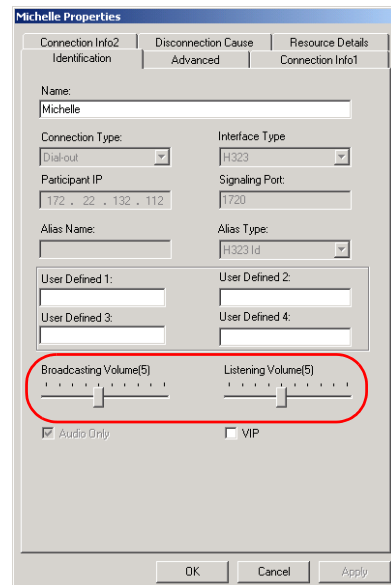

IP Participant Identification Properties

2. Move the slider to the right or to the left to increase or to lower the Broadcasting or Listening Volume level for a participant:
 - The Volume scale is between 1 to 10, where 1 is the lowest and 10 is the highest. The default volume at the connection time is 5.
 - Each movement of the Volume slider increases or reduces the volume by one unit that is equivalent to 3 dB.
3. Click **OK**.



Participants in an On Going Conference can adjust the volume of the audio transmitted from and to their endpoint, using the appropriate DTMF code:

- Broadcasting volume: to increase the volume, use ***9**; to lower - **#9**.
- Listening volume: to increase, use ***76**; to lower - **#76**.

Muting and Unmuting Participant's Audio

Occasionally, a conference organizer may want to exclude the audio of a specific participant from part of an On Going Conference. A participant whose audio channel is muted hears the other participants while the other participants cannot hear the muted participant.

Participants' audio can be muted by the MCU, by the operator, by themselves or by a combination MCU/operator; Operator/participant

For listing of audio status icons, see Table 3-4, "Participant Audio Status Icons," on page 3-16.

Participants can mute their audio transmission from their own endpoints, using DTMF codes. The default DTMF code for muting individual's line is ***6**, and **#6** for unmuting the line. *Muting By Participant* is indicated by a special  icon.

You can mute a participant's audio from the participant's right-click menu or in the *Participant Properties* dialog box.

To mute/un-mute participant's audio:

- *Using the participant right-click menu:*
 - a. In the *Browse, Monitor* or *Status* pane, right-click the participant's icon, and then click **Mute Audio**.



The menu option changes to *Un-mute Audio* and the status of the audio channel in the *Audio* column in the *Status* and *Monitor* panes changes to “Mute Audio”.

Muting by Operator is indicated by a special  icon.

- b. To unmute the audio channel for a participant, right-click the participant's icon and then click **Unmute Audio**.

- From the *Participant Properties* dialog box:
 - a. In any pane of the main window, right-click the participant's icon, and then click **Properties**.
The *Participant's Properties - Identification* dialog box opens.

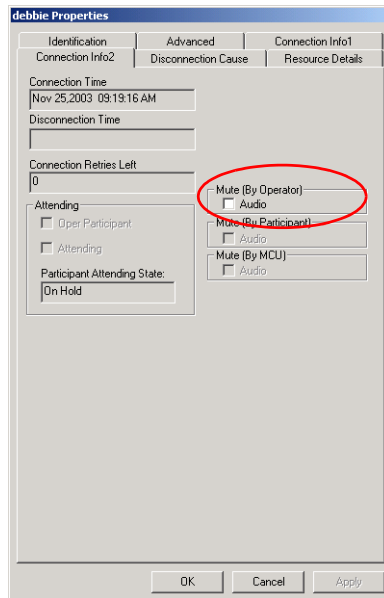

*ISDN/Telephone Participant
Connection Info2 Properties*

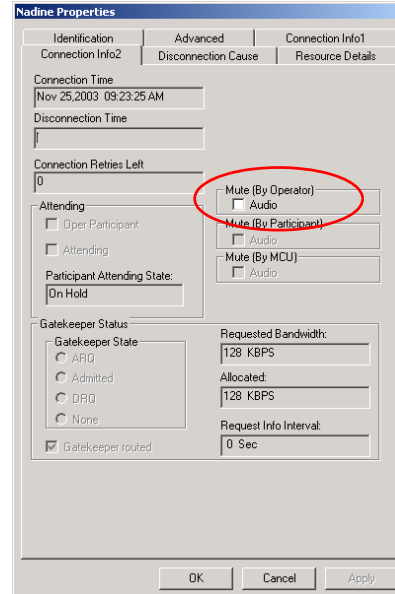

*IP Participant
Connection Info2 Properties*

- b. Click the **Connection Info2** tab.
The *Participant's Properties - Connection Info2* dialog box opens.
- c. In the *Mute (By Operator)* box, check the **Audio** option, and then click **OK**.
The dialog box closes and muting takes effect. The *Muted Participant* icon appears in the *Audio* column in the *Monitor* and *Status* panes.
To un-mute the audio using this method, clear the *Mute (By Operator) Audio* check box.

Enabling/Disabling Auto Gain Control (AGC)

Endpoints and phones vary in the types of source noise and volume they produce. The Auto Gain Control (AGC) mechanism balances noise and volume of the received audio signals, for conference participants. AGC is applied to all incoming audio streams before mixing, and dynamically changes the amplification of the input signal to provide a constant output amplitude.

The intensity of input signals can vary due to the following factors:

- Microphone properties and adjustments
- Background noise
- Speaker's distance from microphone
- Speaker's manner of speech



- The AGC option is applicable to all participants using Audio+ resources.
- The AGC option is enabled in the "system.cfg" in the AUDIO PLUS FLAGS section. By default, the AGC flag is set to YES, and when defining new participants, the AGC option is selected.

In some cases, you may need to disable AGC for a participant during a conference.

You can enable or disable AGC using the participant's right-click menu or in the *Participant Properties* dialog box. For more details about participant properties modifications, see Chapter 2, "Defining Participant Properties" on page 2-49.

Modifying the Participant's User Defined Properties

In the *Participant Properties* dialog box *User Defined* fields, you can enter (or edit) additional information that identifies the participant, such as the email address, company name or job title. The User Defined fields are displayed by default, however, if you do not see them, you can configure the *Participant Properties* dialog box to include them, and you can also modify their titles. This is done in the *Database Manager* application. For more details about changing the User Defined fields, see MGC Manager User's Guide Vol. I. Chapter 6, "Operations Performed During On Going Conferences"

To modify the User Defined fields in participant's properties:

1. Open the *Participant's Properties - Identification* dialog box and enter any required general information about the participant into any or all of the *User Defined* fields.

The screenshot shows the 'Planning Dept. #1 Properties' dialog box with the 'Identification' tab selected. The 'User Defined' section is highlighted with a red box. The fields are as follows:

User Defined 1:	User Defined 2:
Planning Dept. head	local office
User Defined 3:	User Defined 4:

Other visible fields include: Name: Planning Dept. #1, Connection Type: Dial-out, Interface Type: H323, Participant IP: 255 . 255 . 255 . 255, Signaling Port: 1720, Alias Name: john, Alias Type: H323 ID, Extension/Identifier String: 456. There are also sliders for Broadcasting Volume(5) and Listening Volume(5), and checkboxes for Audio Only and VIP.

2. Click **OK**.
The information is updated.

Conference Level Operations

Adding New Participants to a Conference

Occasionally you may be required to add a defined participant after a conference has begun. To do this, you can use one of the following methods

- Define a new participant:
 - using the conference right-click menu
 - using the conference toolbar
 - using the Conference Properties dialog box
- Add a defined participant from the Participant Database or from a User Template file. For more details, see Chapter 2, “Defining Participant Properties” on page 2-49.
- Copy a participant from another conference or a conference template.



When defining a participant, during an On Going Audio Only conference, only the participant properties relevant to the type of conference to which the participant is added, are enabled.

If the conference is a *Meet Me Per* conference, undefined participants can connect to the conference directly or through an Entry Queue.

To define a new participant:

- *Using the Conference right-click menu:*
 - a. Expand the *On Going Conferences* list, right-click the icon of the conference to which to add the participant, and then click **New Participant**.

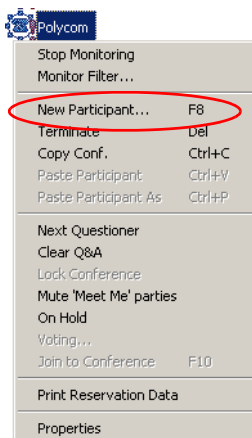

The *Participant Properties* dialog box opens.

- b. Set up the required properties in the *Identification* and *Advanced* tabs of the *Participants Properties* dialog box. For detailed information on defining participants, see Chapter 2, “Defining Participant Properties” on page 2-49.
 - c. Click **OK**.
The new participant is added to the conference and is displayed in all the panes of the main window.
- *From the Conference toolbar:*
 - a. Expand the *On Going Conferences* list, click the icon of the conference to which to add the participant, and then click the **New Participant** button  on the Conference toolbar.
The *Participant Properties* dialog box opens.
 - b. Repeat the steps *b* and *c* of the previous procedure.
 - *From the Conference Properties dialog box:*

- a. Expand the *On Going Conferences* list, right-click the icon of the conference to which to add the participant, and then click **Properties**. The *Conference Properties* dialog box opens.
- b. Click the **Participants** tab.

The *Conference Properties – Participants* dialog box opens.

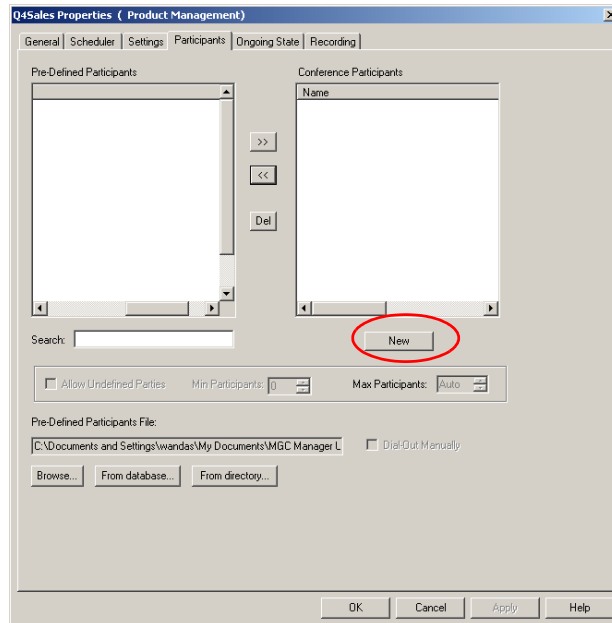

- c. Click the **New** button.
The *Participant Properties* dialog box opens.
- d. Set up the required properties in the *Identification* and *Advanced* tabs of the *Participants Properties* dialog box. For a detailed description of participant definition, see Chapter 2, “Defining Participant Properties” on page 2-49.
- e. Click **OK**.
The new participant is listed in the *Conference Participants* list.
- f. If required, repeat steps *c - e* to add more participants.
- g. Click **OK** to complete the conference editing.
The new participant is listed in all the panes of the main window.

To copy the participant properties from an On Going Conference or Reservation:

Participants can be added to a conference by copying their parameters from another conference. You can copy a participant from one On Going Conference or Reservations to another.

1. In the *Browser* pane, expand the *Reservations* or the *On Going Conferences* list, and then expand the *Reservation/On Going Conference* icon to list its participants.
2. Right-click the icon of the participant to copy, and then click **Copy Participant**.

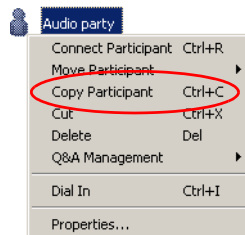

3. Right-click the conference/reservation icon to which to copy the participant, and then click **Paste Participant**.

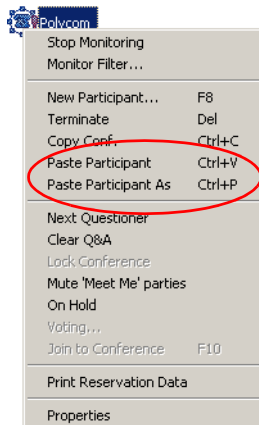

The participant's details are copied to the selected conference/reservation under the same name.

To paste the participant parameters while changing the name and other parameters, click **Paste Participant As**.

The *Participant - Properties* dialog box opens.

4. Change the participant's parameters, and then click **OK**.
The modified participant is copied to the conference/reservation.
For detailed information on defining participants, see Chapter 2, "Defining Participant Properties" on page 2-49.

To copy the participant properties from a Database Reservation template or from the Participant Template:

You can copy a participant from a participant template to another participant template, or to another conference.

1. Open the *Reservation in Database* window or *Participants in Database* window, as described in the MGC Manager User's Guide, Volume II.
2. Expand the *Groups* tree. In the *Reservations in Database* window, locate the Reservation template containing the participant that you wish to copy.
3. In the *Participants in Database* window, locate the Participant template to copy.
4. Expand the Reservation template tree to list its participants.

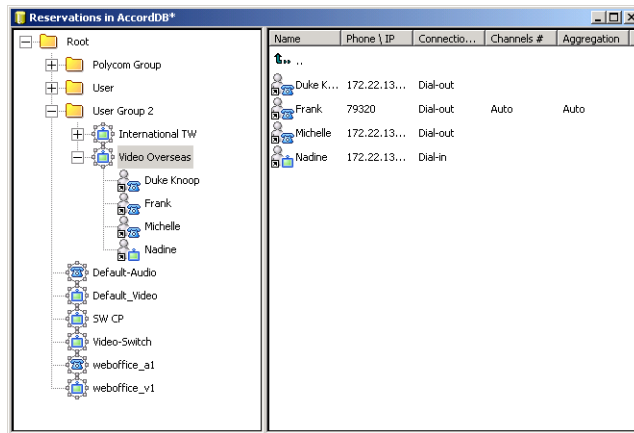

5. Right-click the icon of the participant to copy, and then click **Copy**.

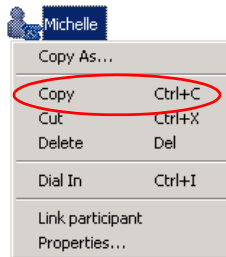

The participant details are copied to the clipboard.

- a. To copy the participant under a new name, click **Copy As**.

The *Participant - Properties* dialog box opens.

- b. Change the participant's name, and then click **OK**.

The participant's details will be copied to the clipboard under the new name.

6. In the Reservation database, the On Going Conferences, or Reservations list, right-click the conference icon to which you wish to copy the participant, and then click **Paste**.

The participant's details will be copied to the new conference reservation under the same name.

- a. Alternatively, click **Paste As** to copy the participant's details to the new conference/reservation under a new name.

The *Participant - Properties* dialog box opens.

- b. Type the new name for the participant, and then click **OK**.

The participant is copied under the new name to the On Going Conference, reservation or Reservation template.

Muting Dial-In Participants Upon Connection

You can set a conference to automatically mute all dial-in participants who were not defined before or during the On Going Conference. You can enable this option when defining a conference/reservation, or during an On Going Conference by the following methods:

- From the conference right-click menu
- From the chairperson DTMF input device (remote control/telephone), pressing the appropriate DTMF code

When the Mute “*Meet Me*” Parties option is cancelled, undefined participants who dial in, are not muted. However, the participants who were previously muted by the MCU using this feature, are not automatically unmuted when this option is cancelled.





- The Mute “Meet Me” Parties feature applies to undefined participants connecting to Meeting Room, Meet Me per Conference Access conference types.

This feature does not apply to standard pre-defined dial-in participants.

To activate the Mute “Meet Me” Parties feature:

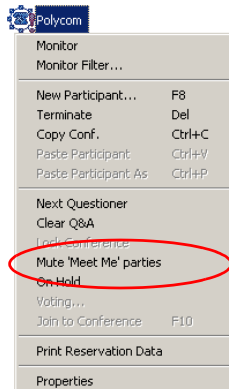
1. Expand the *On Going Conferences* list.
2. Right-click the icon of the conference and click **Mute ‘Meet Me’ Parties**.



From this point on, all incoming parties are automatically muted by the MCU. This status is indicated by the appropriate icon  in the Audio column of the *Monitor* and *Status* pane.



Participants remain muted until you manually unmute them.

To cancel the Mute “Meet Me” Parties feature:

1. Expand the *On Going Conferences* list.
2. Right-click the conference icon and click **Un-mute ‘Meet Me’ Parties**.

Adding Remarks During an On Going Conference

In the *Conference Properties - General* dialog box, you can add and save any text (for example conference information or a comment) during the conference setup or during the On Going Conference in the *Remarks* section. All remarks are displayed in the *Remarks History* box, in the ascending order (latest entry at top of the list). Remarks can also be added from the Web via the WebCommander application. The entries are added to the CDR file, for retrieval during the billing stage.

To enter and save a remark during an On Going Conference.

1. Open the *On Going Conference Properties* dialog box, and if required, click the **General** tab.

The *On Going Conference Properties - General* dialog box opens.

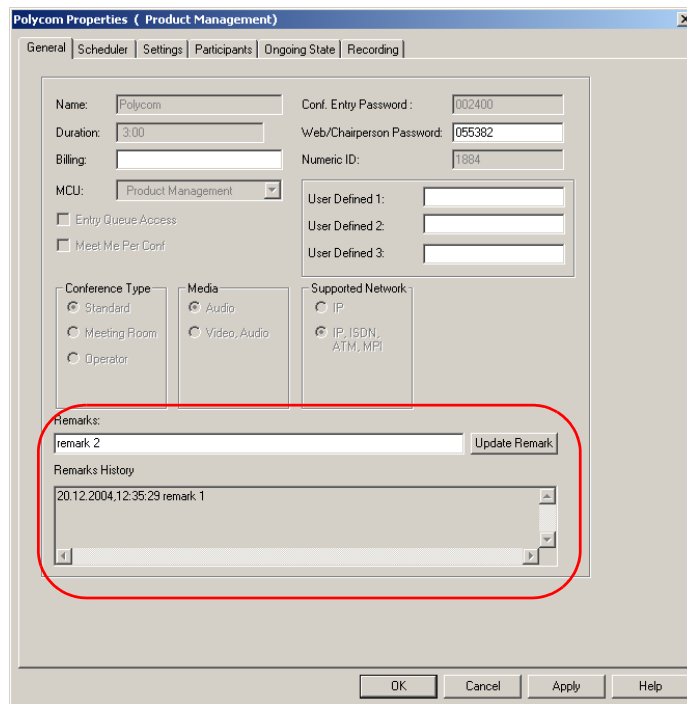

2. In the *Remarks* box, enter text (up to 300 characters).
3. Click **Update Remark**.

To add a remark longer than 300 characters, split the text into several remarks, using the *Update Remarks* button to save the current remark and start a new remark.

To add multiple remarks, repeat steps 2 and 3.

4. Click **OK**.

The dialog box closes and the new remark is written to the CDR file and moved to the *Remarks History* box.

Locking and Unlocking a Conference

The operator or chairperson can lock or unlock an On Going Conference to undefined dial-in participants. In addition, you can lock a conference during its definition and, if required, unlock it while it is going on. The purpose of conference locking is to:

- Limit the number of undefined dial-in participants connecting to the conference
- Prevent additional participants from connecting to the conference once all the required participants are connected
- Save resources

You can lock and unlock the conference from the right-click menu, from the toolbar or from the *Conference - Properties* dialog box.

Alternatively, chairpersons can lock or unlock a conference from their endpoint using the appropriate DTMF code. The default code is **#7** for locking; ***7** for unlocking.

To lock and unlock an On Going Conference:

- *Using the Conference right-click menu:*
 - a. Expand the *On Going Conferences* list.
 - b. Right-click the conference icon and then click **Lock Conference**.

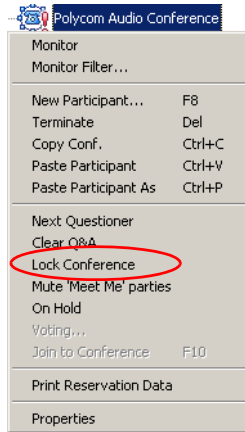

The *Locked Conference* icon  is displayed in the *Status* column in the *Monitor* and *Status* panes. The conference is now locked to new dial-in participants.



To unlock a locked conference, expand the *On Going Conferences* list, right-click the icon of the conference to unlock, and then click **Unlock Conference**.

The status of this conference in the *Monitor* and *Status* panes is updated to *Unlocked* and the conference reverts to its regular state.

New dial-in participants can now connect to the On Going Conference.

- *Using the Conference toolbar:*
 - a. Expand the *On Going Conferences* list, and then click the icon of the conference to lock.
 - b. Click the **Lock Conference** button on the Conference toolbar.



The *Locked Conference* icon  and the *Lock* button  on the *Conference* toolbar indicate that the conference is now locked to new dial-in participants.



Placing a cursor on top of the Lock button displays a tooltip with the operation that will be performed once the button is clicked.

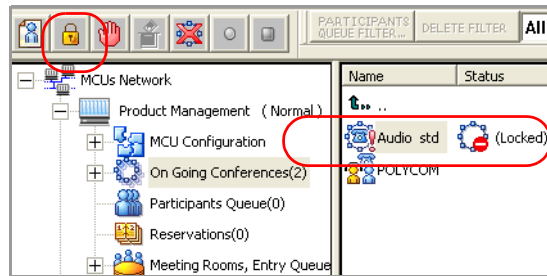

To unlock a locked conference, expand the *On Going Conferences* list, click the icon of the conference to unlock and then click the **Unlock Conference** button on the *Conference* toolbar.

The conference reverts to the unlocked state and its status and indicators in the *Monitor* and *Status* panes are updated accordingly. New dial-in participants can now connect to the On Going Conference.

- From the *Conference Properties* dialog box:



You can lock a conference during the definition stage only when the *Meet Me per Conf* option is enabled or with the *Meeting Room* conference type.

- In the *On Going Conference Properties* dialog box, click the *Settings* tab.
- If required, in the *General Settings* section, click the **Advanced** button.

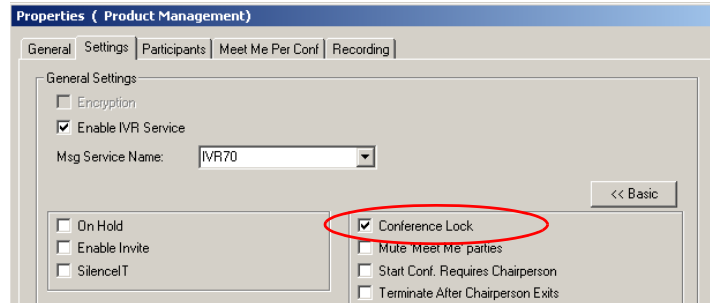

- c. In the *General Settings* section, click **Conference Lock**.
- d. Click **OK**.

The dialog box closes. The *Locked Conference* icon indicates the current status of this conference in the *Status* column, in the *Monitor* pane. When the On Going Conference starts, it remains locked until unlocked or until it ends.

To unlock a conference, repeat steps a and b then clear the **Conference Lock** check box, use the conference toolbar button or the right click menu. The conference reverts to the unlocked state and its status and indicators in the *Monitor* and *Status* panes are updated accordingly. New dial-in participants can now connect to the On Going Conference.

Managing Question-and-Answer Sessions

The Question-and-Answer (Q&A) session provides a method of organizing the participants questions or comments during a lecture or a large conference.

During a typical large conference or lecture, all participants excluding the lecturer or the main speaker, are muted by the system. A participant who wants to ask a question or comment on the subject being discussed, presses the appropriate code on the DTMF input device (the default code is *22) to enter the Q&A queue. Participants queue in the order in which they have requested to ask a question.

You can also place participants in the Q&A queue from the MGC Manager application using the Q&A toolbar.

Once the participant is in the Q&A queue, you can select them to ask the question or let the next participant in line ask the question. If the participant is muted by the MCU, for example in the *Exclusive Speaker* mode, you have to unmute the participant before you let him or her ask the question.

You can stop the questioner any time during the question, or you can end the current Q&A session by selecting the appropriate function in the MGC Manager application. The chairperson can end the Q&A session using the appropriate code on the DTMF input device.

You can also end the session by clearing the Q&A queue.

You can change the position of the participants in the queue, moving a selected participant's position up or down the queue or to the first or last position in the queue.



- A Q&A session requires the use of a DTMF input device.
- The Q&A session managing options are applicable only to conferences with an assigned IVR Service running on an Audio+ card.





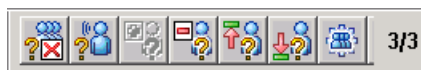



Controlling Q&A Queues with the Toolbar

You can easily manage the Q&A queues using the dedicated toolbar. Enable this toolbar by clicking a participant icon in an On Going Conference or by clicking the icon of a participant waiting in the Q&A queue.



The Q&A toolbar contains the following buttons:

Table 4-1: Q&A Toolbar Buttons

Function	Button	Description
<i>Clear QA</i>		Clears all participants from the Q&A queue.
<i>Next Questioner</i>		Lets the next participant in the Q&A queue or the selected participant ask a question.
<i>Add Participant to Q&A</i>		Adds a participant to the Q&A queue.
<i>Remove Participant from Q&A</i>		Removes a participant from the Q&A queue.
<i>Move participant to first position in Q&A</i>		Moves the participant to the first position in the Q&A queue (enabling this participant to become the next questioner).
<i>Move participant to last position in Q&A</i>		Moves the participant to the end of the Q&A queue.
<i>View All Q&A Participants</i>		To view only participants waiting in the Q&A queue.
<i>View All</i>		To view all participants in the conference.
<i>Q&A Parties out of Total Parties</i>	1/10	Displays the number of participants currently waiting participants in the Q&A queue and the total number of participants connected to the conference.

Adding Questioners to the Q&A Queues

Participants can be added as questioners to the Q&A queue using one of the following options:

- Questioners are added to the Q&A queue once they press the appropriate DTMF code on their DTMF input device (default DTMF code is *22). An appropriate audio message is played to confirm the participant addition to the Q&A queue.

- Questioners can also be added to the queue manually from the MGC Manager application. In the *Browser*, *Status* or *Monitor* panes, right-click the icon of the participant to add to the queue.

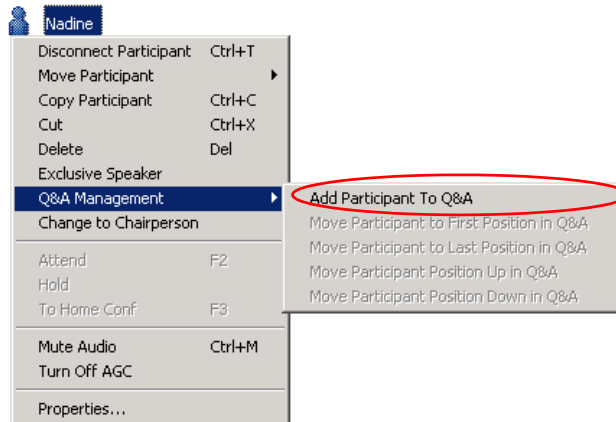

The participant icon changes, to indicate that the participant was added to the Q&A queue.

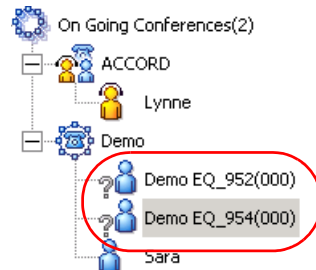

In addition, the *Monitor* table displays detailed information.

Name	Status	Connection	Network+Phone/IP	Connection Type	Sync.	Audio	QA position	QA Waiting Time
ACCORD (Alpha 06 ID: 4911)	Single Particip...							
Lynne		Connected	99251284	Dial-out	O.K			
Polycom (Alpha 06 ID: 4915)	3 - Connected;							
Debbie		Connected	172.22.132.6	Dial-out	O.K		1	00:18:28
Frank		Connected	79320	Dial-out	O.K		2	00:17:37
Michelle		Connected	172.22.132.112	Dial-out	O.K		3	00:17:31

- The *QA Position* column shows the order of the participants who have requested to ask a question in the Q&A queue.
- The *QA Waiting Time* column displays the length of time the participant has been waiting in the Q&A queue.

Note that in the above figure, the Q&A columns were moved to the left. By default, these columns are located on the right of the *Monitor* pane and you need to use the scrolling arrows to display them.

Changing Participant's Position in Q&A Queue

You can change the position of any participant in the Q&A queue when you want certain participants (such as participants designated as VIP) to ask questions first, and others to be moved to the end of the queue.

To change the participant's position in the Q&A queue:

- Right-click the *Participant* icon, click **Q&A Management** and then select the required position.

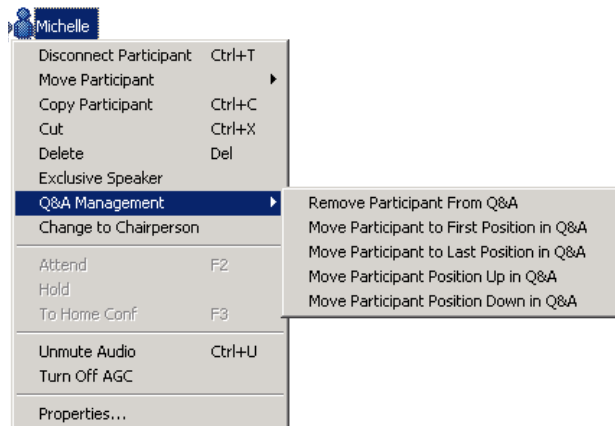

You can move participants to the following positions in the Q&A queue:

- First position
- Last position
- Up one position
- Down one position
- Alternatively, select the participant to move by clicking the *Participant* icon, and then, on the Q&A toolbar, click:

-  to move the participant to the first position in Q&A queue
- or

-  to move the participant to the last position in Q&A queue

Allowing Participant Questions

Participants in the Q&A queue can ask a question after the permission is granted to them by the conference chairperson or the operator.

- The operator clicks the *Next Questioner* button in the Q&A toolbar. If the participant is muted, the operator must first unmute the participant.
- The operator selects the participant to ask the question and clicks the *Next Questioner* button in the Q&A toolbar.
- The chairperson enters the appropriate code on the DTMF input device to let the first participant in the queue ask the question. The default code is 2. The selected participant's icon now indicates the change of status to *current questioner*:

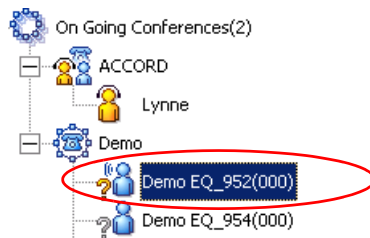

Ending Participant Questions

Ending the questioner session can be done by participants or by the chairperson.

- The operator can end the questioner session by right-clicking the *Questioner* icon, and then clicking **Stop Questioner Session**.
- Participants can indicate that they have completed asking the question by entering the appropriate DTMF code (the default code is #22).
- The chairperson can stop the current questioner by pressing the

appropriate DTMF code (the default code is #23).

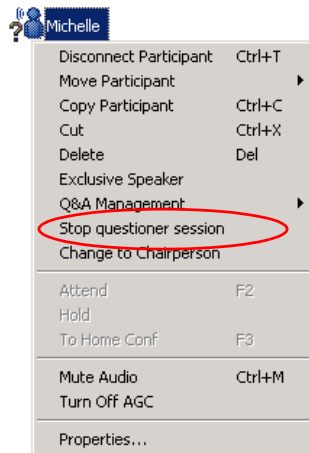

The selected participant's icon reverts to the passive/normal status.

Removing Participants from the Q&A Queue

You can remove a participant from the Q&A queue at any given time during the Q&A session. In such a case, the session will continue as before but the removed participant will not be able to ask questions in this session.

To remove a participant from the Q&A queue:

- Right-click the participant's icon, click **Q&A Management**, and then click **Remove Participant from Q&A**

or

select the participant's icon, and then click the **Remove Participant**

from Q&A button  on the *Q&A* toolbar.

The participant is deleted from the Q&A queue and remains in the On Going Conference.

Clearing Q&A Queues

The chairperson and the operator can clear the Q&A queue at any given time during the Q&A session. In that case, all the participants currently waiting in the Q&A queue are removed from the queue and they will not be able to ask questions in this session.

To end the Q&A session and clear the queue:

The Q&A session can be ended by either the operator or the chairperson.

- The operator clicks the *Clear QA* button  on the Q&A toolbar.
- The chairperson enters the appropriate DTMF code (the default code is #24).

Once the Q&A queue is emptied, the Q&A session is over. Participants revert to the standard status and icons (according to their role).

Managing Voting Sessions

In a voting session, participants express their preference on a set of choices using the touch-tone keypad during an On Going Conference. The system uses digits to correlate participant votes to the items for which they are voting.

A voting session can include up to 10 choices for one subject. Each choice is assigned a digit (between 0 to 9) and a descriptive title. For example, in an employees meeting, the employees have to vote for one of the benefit plans suggested by the management. Each plan is assigned a digit (for example, if there are 5 plans, the choices may be 0 to 4) and a short description.

A voting session consists of three main stages:

- *Preparation stage* - Before the voting session begins, the operator or the chairperson (using the WebCommander application) creates the list of choices and their descriptions. The operator or the chairperson then informs the conference participants of the choices available for selection and the digit assigned to each option.
- *Voting stage* - When voting, each participant enters the digit that represents the participant's choice, using the DTMF input device. As each vote is counted, the information is presented on-line in the Voting window.
- *Results stage* - When the voting is completed, the final results are viewed. The operator or the chairperson can save the voting results to a file or start a new vote.



Voting sessions are available in IVR enabled conferences that are run on Audio+ cards and require the use of a DTMF input device.

Conducting a Voting Session

The operator or the chairperson manages the voting session.

To manage a voting session conference:

1. In the *Browser* or *Monitor* panes, right-click the conference icon, and then click **Voting**.

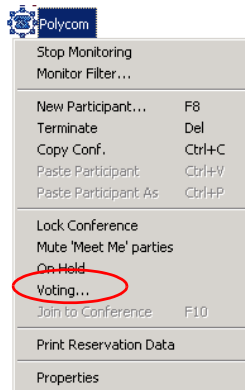

The *Voting* dialog box opens. You can now configure the settings for the voting session.

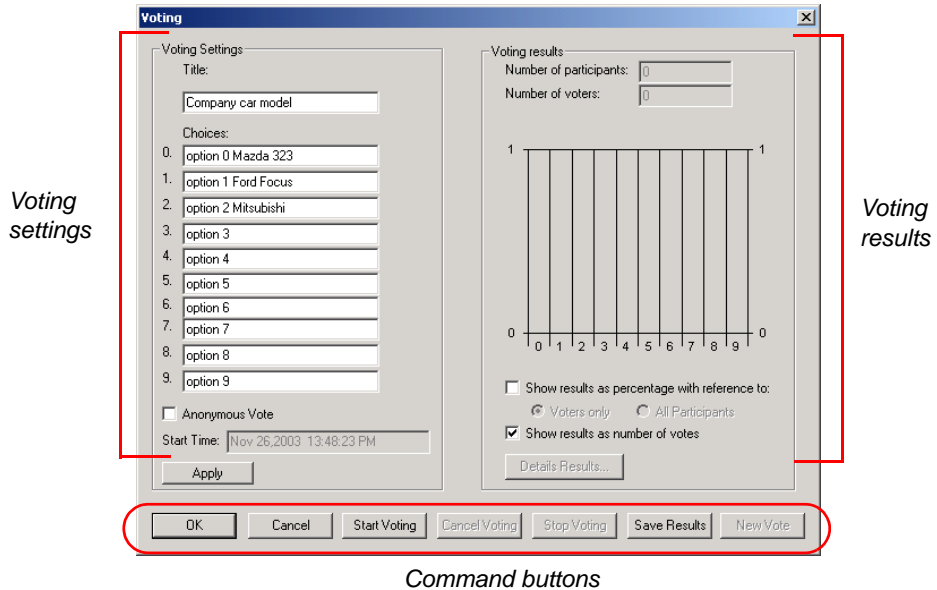

The *Voting* dialog box information is organized in these sections:

- *Voting Settings* - where you define the voting session parameters.
- *Voting Results* - where the system displays the voting results parameters, updating them as the voting session progresses.

The Command buttons let you select optional operations.

2. In the *Voting Settings* section, define the Voting Session parameters as follows:

Table 4-2: Voting Session Settings

Field/Option	Description
<i>Title</i>	Enter the Voting subject. This title is also used as the file name when saving the results to a file.
<i>Choices</i>	The digits 0 to 9 on the left (which cannot be selected or modified) represent the digit that should be pressed on the telephone keypad or the remote control. Enter a descriptive text for each of the choices to be selected during the voting session. For example, for digit 0 enter the first choice, for digit1 enter the second choice, etc. This text will appear in the voting results and is saved together with the voting results.
<i>Anonymous Vote</i>	Select this option to conduct an anonymous voting session.
<i>Start Time</i>	Displays the voting session start time.

3. Click **Apply** to save the voting settings.
4. Present the voting choices to all the conference participants.
Once the voting choices are clear to all, the voting stage can start.
5. In the Command buttons section, click **Start Voting**.
 - Click **Start Voting**.
 - Alternatively, start the voting session from the touch-tone telephone or remote control by entering the appropriate DTMF code (the default code is ***81**).
6. Participants enter their vote by pressing the appropriate code assigned to each choice.



You can start or cancel a voting session by clicking the *Enable/Cancel Voting* button on the Conference toolbar.

The voting results are shown in the *Voting Results* section.

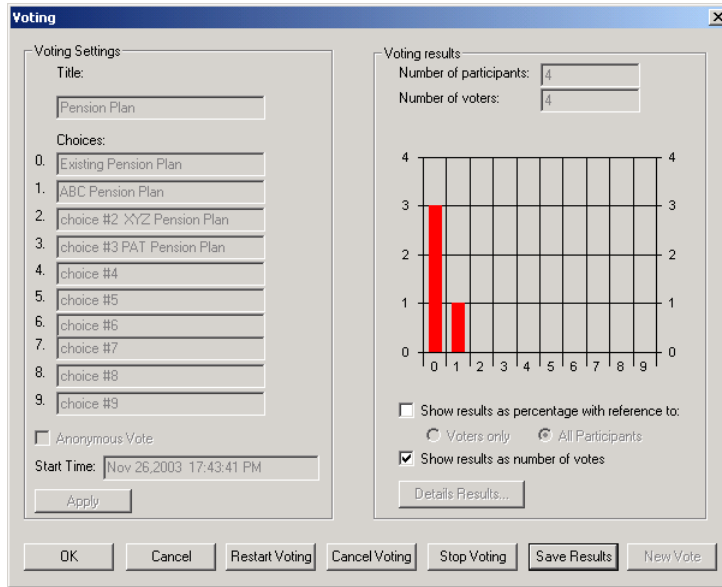

The following information is displayed in the Voting Results pane:

Table 4-3: Voting Results Parameters

Field/Option	Description
<i>Number of Participants</i>	Displays the number of participants currently connected to the conference.
<i>Number of Voters</i>	Displays the number of participants who have already voted. This number is updated continuously according to the number of voters.
<i>Show results as percentage with reference to:</i>	Select this option to display the number of votes for each choice as percentage. If checked, select the category from which to calculate the percentage: <ul style="list-style-type: none"> • Voters Only – Displays the percentage of participants who voted for each choice, out of the total number of voters. • All Participants – Displays the percentage of participants who voted for each of choice, out of the total number of connected participants.

Table 4-3: Voting Results Parameters (Continued)

Field/Option	Description
<i>Show Results as Number of Votes</i>	Select this option to display the absolute number of votes cast for each choice.
<i>Details Results</i>	Click this button to display a summary of the voting results. Note: Detailed results can be viewed only when the voting stage is completed.

- Click the **Stop Voting** button to conclude the voting session. Alternatively, chairpersons can end the voting session by entering the appropriate DTMF code (default DTMF code is **#81**). The voting results are displayed on the screen and can be saved to a text file.

At this point, you can select one of the following options in the *Voting* window, using the command buttons:

- Click **Restart Voting** to restart the voting on the same subject, for example if the previous voting session was interrupted or if you need to recount the votes.
A new voting stage starts immediately, using the current settings.
- Click **New Vote** to start a new voting subject.
The current settings are cleared from the *Voting Settings* pane. Repeat the preparation stage procedure as described in “Conducting a Voting Session” on page 4-43, steps 1 through 3.
- Click **Results** to display full information about the voting results.
- Click **Save Results** to save the results to a text file.
- Click **OK** to exit the voting session.
The dialog box closes.

Viewing and Saving Voting Results

To view voting results:

- Click **Details Results** to display the full information about the results of the voting session.
The *Voting Details* window opens. For each option, the system displays the total number of votes.

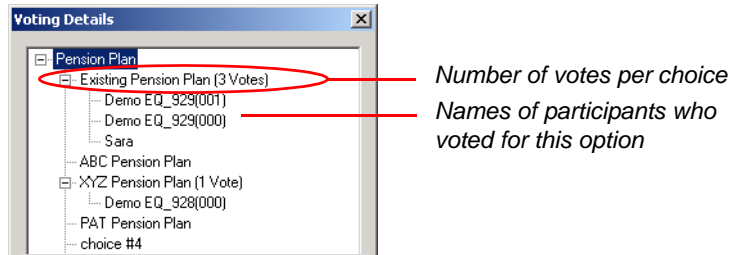

- If the vote was not anonymous, you can view the names of the participants who have voted for each of the listed choices. To display names, click the [+] icon next to the choice name.
- If the vote was anonymous, the system displays only the number of votes for each choice.

2. Click **OK** to close the *Voting Details* window.

To save the voting results file:

1. In the *Voting* window, click the **Save Results** button to save the results to a text file.

The *Save As* dialog box opens.

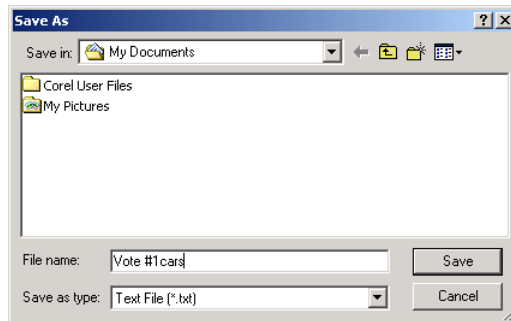

The *File Name* field displays the default name, derived from the voting session's title. You can modify this file name. The file can be saved only in the text or ASCII format (*.txt).

2. Using the standard Windows conventions, select the destination folder for the file, and then click **Save**.

The dialog box closes, and you return to the *Voting* dialog box.

3. Click **OK** to close the *Voting* dialog box.

To view the voting results file:

- Using any word processor, open the text file.

Following is a sample of voting results text file.



```
Pension Plan
-----
Q. Existing Pension Plan (3 Votes)
-----
    Demo EQ_929 (001)
    Demo EQ_928 (000)
    Sara
-----
1. ABC Pension (1 Vote)
    Demo EQ_928 (000)
-----
2. XYZ Pension Plan
-----
3. PAT Pension Plan
-----
4. choice #4
-----
5. choice #5
-----
6. choice #6
-----
7. choice #7
-----
8. choice #8
```

Placing a Conference On Hold

An operator or a chairperson can place an On Going Conference On Hold. In this state, conference participants hear background music. If you place the conference On Hold during its definition or when starting it, you can cancel the On Hold state later, for example when all the participants have successfully connected.

You can activate and deactivate the On Hold function from the Conference right-click menu, from the Conference toolbar or from the *On Going Conference - Properties* dialog box.

Alternatively, chairpersons can place a conference on hold, using the appropriate DTMF code (the default DTMF code is *1).

When the conference is placed on hold, the *Conference On Hold* icon  is displayed in the *Status* column in the *Monitor* and *Status* panes and the *Release On Hold Conference* button  is displayed in the Conference toolbar.

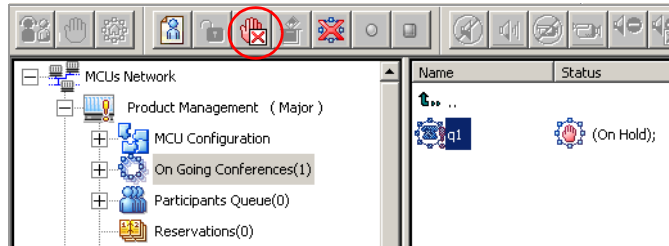

All connected participants hear background music until the conference is reinstated. When the conference is reinstated, all the conference statuses and icons are updated accordingly.

To place an On Going Conference On Hold:

- *Using the Conference right-click menu:*
 - a. Expand the *On Going Conferences* list.
 - b. Right-click the icon of the conference to place On Hold, and then click **On Hold**.

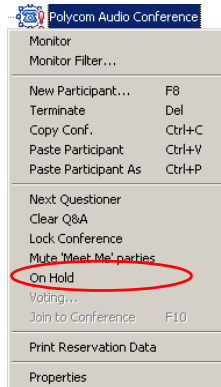

The On Going Conference is placed on hold immediately.

To reinstate the conference, expand the *On Going Conferences* list, and then right-click the icon of the conference that is currently on hold, and then click **Release Hold**.

- *Using the Conference Toolbar:*
 - a. Expand the *On Going Conferences* list and click the icon of the conference to place On Hold.

- b. On the Conference toolbar, click the **Hold Conference** button.



To release the conference, click the conference icon then click the **Release Hold** button on the Conference toolbar.

- *From the Conference Properties dialog box.*
 - a. In the *On Going Conference Properties* dialog box, click the *Settings* tab.

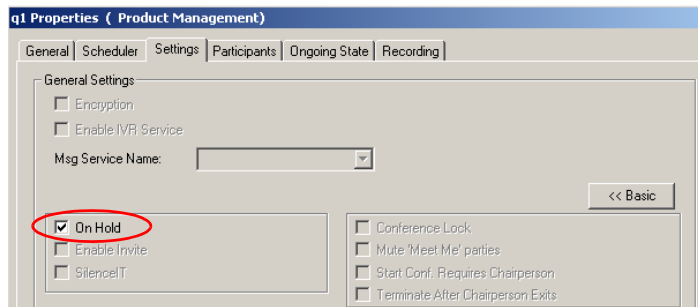

- b. If required, click the **Advanced** button.
- c. In the *General Settings* pane, select **On Hold**, then click **OK**. The dialog box closes.

To release the conference, repeat steps a and b, then clear the **On Hold** check box.

Modifying Conference General Parameters

During an On Going Conference, you can modify the following parameters

- The conference Billing Code
- General Information about the conference in the User Defined fields
- The conference and chairperson passwords

To modify the conference general parameters:

1. Right-click the *On Going Conference* icon, and then click **Properties**. The *Conference Properties - General* dialog box opens.

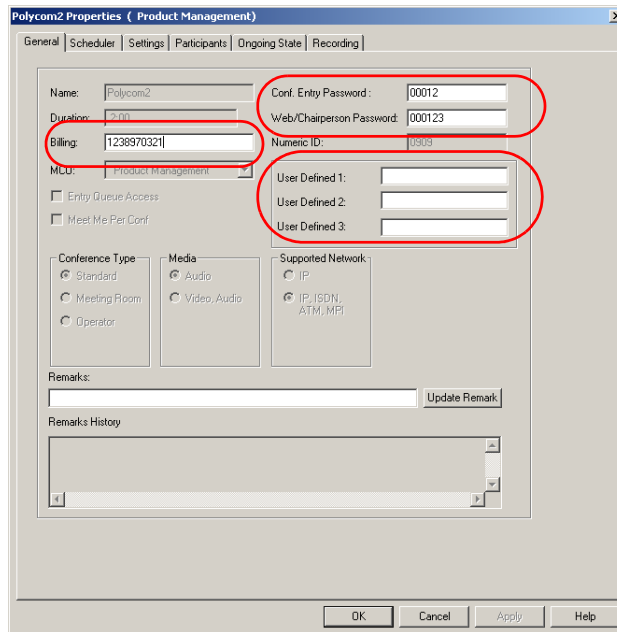

2. Enter the conference Billing code; general information, such as company name, contact person, email address, telephone number etc. and if required, modify the conference or chairperson password.
3. Click **OK**.
From this point on, the modified information is applicable to this On Going Conference.

Changing the Conference Duration

At times, operators may find it necessary to extend the duration of a conference or terminate a conference before its scheduled completion time. The conference can be manually or automatically extended or terminated.

To manually extend an On Going Conference:

You can extend a conference's duration after the conference has started.

1. Open the *Conference Properties* dialog box.
2. Click the **Scheduler** tab.
3. Modify the conference *Ending Time*.

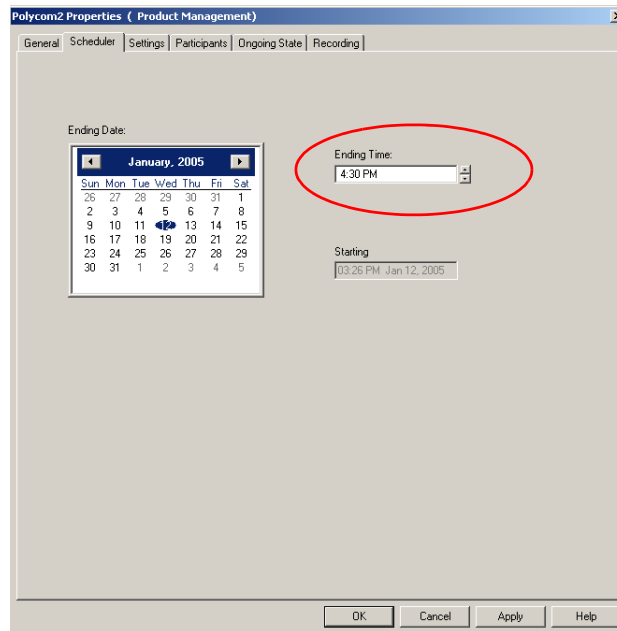

4. Click **OK** to apply the settings.

The *Conference Properties* dialog box closes.



The time format is derived from the Operating System time format defined in the Regional Settings.

Ending a Conference before its Scheduled Termination Time

You can manually end the conference before its scheduled end time. Usually, this option is used when all the participants disconnected from the conference, or if the meeting organizer has requested it.

To manually terminate a conference manually:

1. Expand the *On Going Conferences* list, right-click the icon of the conference to end, and then click **Terminate**.

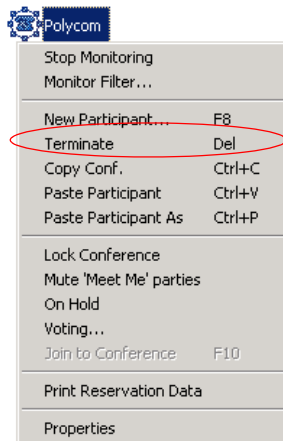

Alternatively, use the shortcut key (the default key is), or click the

Terminate button  on the *Conference* toolbar.

A dialog box appears prompting you to confirm the action.

2. Click **Yes**.
The conference is terminated. The conference name and its icon are removed from the *On Going Conferences* list.

Rescheduling Conference Reservations

In some cases, you may want to reschedule a reservation so the conference will start earlier, immediately, or later than scheduled.

To reschedule a conference reservation:

1. Expand the current *Reservations* tree.
2. Right-click the *Reservations* icon and then click **Properties**.

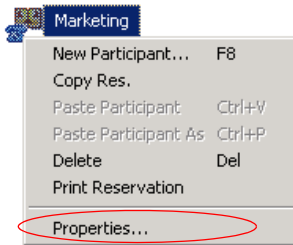

The *Reservation Properties* dialog box opens.

3. Click the **Scheduler** tab.

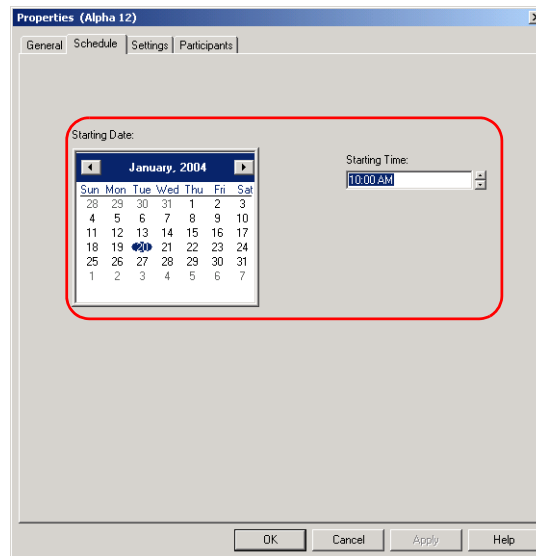

4. Select a different **Starting Date** and **Starting Time**, as required. To start the conference immediately, change the date to the current date and the starting time to the current time.
5. Click **OK**.
The *Conference Properties* dialog box closes.
 - If scheduled to start in the future, the Reservation remains in the *Reservations* list.
 - If scheduled to start immediately, the Reservation becomes an On Going Conference and is moved to the *On Going Conferences* list.

Deleting Recurring Reservations

You can delete a single recurring reservation or delete all the scheduled recurrences. Deleting a single scheduled recurrence is done using the *Reservation* right-click menu. Recurring reservations can be deleted as a group using one of the following methods:

- Using the Recurrent Reservation right-click menu
- Using the Reservations right-click menu

To delete a single recurring reservation:

1. Right-click one of the Recurrent Reservation icons, and click **Delete**.

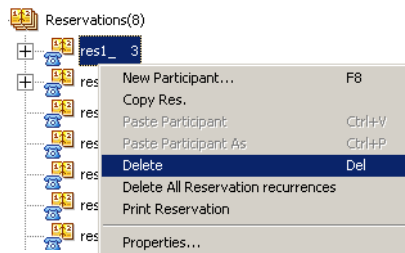

A confirmation box opens.

2. Click **Yes** to delete the selected recurring reservation.
The deleted reservation is removed from the recurrences list.

To delete all recurring reservations:

- *Using the Recurrent Reservation right-click menu:*
 - a. Right-click one of the Recurrent Reservation icons, and then click **Delete All Reservation Recurrences**.

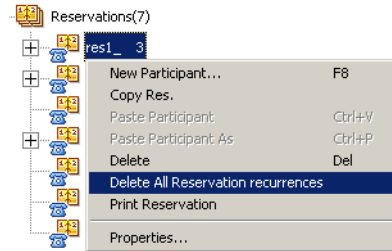

A confirmation box opens.

- b. Click **Yes** to delete all recurring reservations.
All the recurrences of the selected Recurrent Reservation are removed.
- *Using the Reservations right-click menu:*
 - a. Right-click the *Reservations* icon, click **Delete All Reservation Recurrences**, and then select the Reservation whose occurrences to delete.

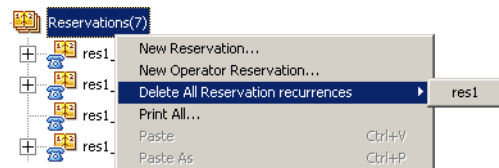

A confirmation box opens.

- b. Click **Yes** to delete all recurring reservations.
All the selected Recurrent Reservations are removed.

Printing Conference Data

Once a reservation is made, the system allocates the appropriate resources to the conference. You can print this data, such as the conference name, ID, start time, duration, line rate, or the participant parameters - to a printer, file or clipboard (to be used by other applications). Printed data can be useful in a variety of situations, for example:

- You can send the printed information about reservations in advance to the conference participants, letting them know the actual conference settings and the dial-in numbers they will use when connecting to the conference.
- You can use the printed data to keep record of all On Going Conferences and planned activities for the MCU or operators.

You can print data for a single On Going or Reservation conference, or for all the On Going or Reservation conferences.



Before printing conference information to a printer, make sure that a default printer is defined in your workstation.

To print details of a single conference:

1. Expand the *On Going Conferences* list or the *Reservations* list.
2. You can print details using one of the following options:
 - In the *Reservations* list, right-click the Reservation icon and then click **Print Reservation**.

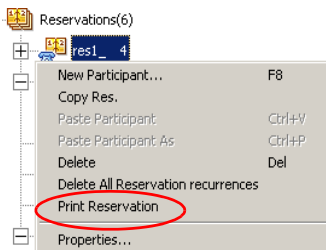

- In the *On Going Conferences* list, right-click the conference icon and then click **Print Reservation Data**.

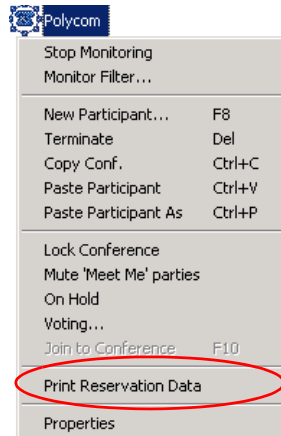

The *Print* dialog box opens.

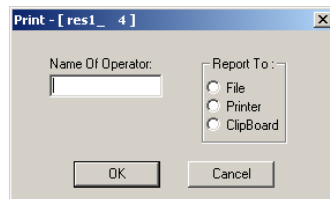

3. In the *Name Of Operator* field, enter the name of the operator who initiated the report
4. In the *Report To* options, select the report destination:
 - **File** - to print data to a text file
 - **Printer** - to print data to the default or other printer
 - **Clipboard** - to copy data to the clipboard from where it can be pasted in other text handling applications
5. Click **OK**.
 - If **File** is selected, the *Save As* dialog box opens.
 - a. Save the conference data to a text file in the desired directory. The system assigns the conference name as the default file name.
 - b. Select the destination folder, enter the required file name, then click **OK**.

- If **Printer** is selected, the conference data is printed to the default printer using the printer's current settings.
- If **Clipboard** is selected, the conference data is copied to the clipboard, from where it can be pasted in other text handling applications.

Following is a sample of Reservation or Conference information.

The first section lists the Reservation general parameters and the second section lists the participant's parameters.

Operator Data

Operator Name - Lynne

Reservation Data

Reservation Name - Demo

Id - 994

Conf. Entry Password - 1234

Web/Chairperson Password - 1122

Start Time - Jan 13, 2003 06:31:12 AM

Duration - 02:00:00

Audio Alg - 56 (G711)

IVR Service Enabled - Yes

IVR Service Name - Demo

Operator Conference - No

Audio Mix Depth - 3

Participants - Sara1

Connection Type - Dial Out

Interface Type - ISDN

Service Name - e1

SubService Name - ZERO

Participant Phone Number(s) - 9054631645;

Num Type - Taken from service

Channel Width - 64 kbps

Number of Channels - 1

Bonding Mode - Off

Chair - No

Voice

Node Type - Terminal

Restrict Only - No

John1

Connection Type - Dial Out

Interface Type - ISDN

Service Name - e1

SubService Name - ZERO

Participant Phone Number(s) - 99251241;

Num Type - Taken from service

Channel Width - 64 kbps

Number of Channels - 1

Bonding Mode - Off

Chair - No

Voice

Node Type - Terminal

To print details of all On Going Conferences or Reservations:

1. Expand the *On Going Conferences* list or the *Reservations* list.
2. You can print details using one of the following options:
 - In the *Reservations* list, right-click the *Reservations* icon, and then click **Print All**.

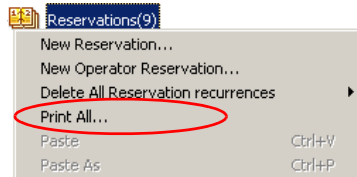

- *On Going Conferences* list, right-click the *On Going Conferences* icon, and then click **Print All**.

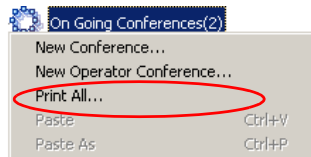

The *Print All* dialog box opens, listing all On Going Conferences or Reservations currently defined or running on the MCU.

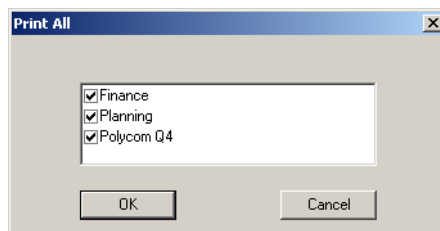

To exclude items from printing, clear the check box next to the name.

3. Click **OK**.
The *Print* dialog box opens.
4. Define the printing options and save the output as described in steps 3, 4, and 5 on page 4-59.



If *File* is selected as the printing destination, the data of all the conferences are printed to the same text file.

Managing Conferences Using DTMF Codes

Participants and chairpersons can manage their On Going Conferences from their endpoints, using the touch-tone signals (DTMF codes).

DTMF Guidelines

- Participants can perform various operations using DTMF codes only if an IVR Service is assigned to the conference.
- Permissions for DTMF actions to be performed by all conference participants or by chairperson only, are configured in the IVR Service (DTMF Codes) assigned to the conference.
- Both the DTMF codes and the user permissions can be modified for individual IVR Services.

Table 4-4 lists the DTMF-driven functions, their corresponding default input codes and user permissions:

Table 4-4: DTMF Operations Performed During Conference

DTMF Function and Message	DTMF Code	Permission
Request private assistance To request private assistance, press: star, zero.	*0	Everyone
Request assistance for conference To request operator's assistance for the conference, press: zero, zero.	00	Chairperson
Mute my line To mute your line, press: star, six.	*6	Everyone
Un-mute my line To un-mute your line, press: pound, six.	#6	Everyone
Lock conference To lock the conference to dial-in participants, press: star, seven, zero.	*70	Chairperson
Unlock conference To unlock the conference, press: pound, seven, zero.	#70	Chairperson

Table 4-4: DTMF Operations Performed During Conference (Continued)

DTMF Function and Message	DTMF Code	Permission
Secure conference To switch the conference to secure mode, press: star, seven, one.	*71	Chairperson
Unsecure conference To cancel the secure mode, press: pound, seven, one.	#71	Chairperson
Increase my broadcasting volume To increase your volume, press: star, nine.	*9	Everyone
Decrease my broadcasting volume To decrease your volume, press: pound, nine.	#9	Everyone
Mute All but me To mute all participants except yourself, press: star, five.	*5	Chairperson
Cancel Mute All but me To cancel mute settings of all participants except yourself, press: pound, five.	#5	Chairperson
Change password To change the chairperson or conference password, press: star, seven, seven.	*77	Chairperson
Place conference on-hold To place the conference on hold, press: star, one.	*1	Chairperson
Reinstate on-hold conference To reinstate a conference on hold, press: pound, one.	#1	Chairperson
Mute dial-in participants To mute dial-in participants, press: star, eight, six.	*86	Chairperson
Cancel Mute dial-in participants To cancel the muting of dial-in participants, press: pound, eight, six.	#86	Chairperson
Start voting session To vote, press: star, eight, one.	*81	Chairperson
Stop voting session To end a voting session and get the results, press: pound, eight, one.	#81	Chairperson

Table 4-4: DTMF Operations Performed During Conference (Continued)

DTMF Function and Message	DTMF Code	Permission
New voting session To start a new voting session, press: star, eight, one.	*82	Chairperson
Cancel voting session To cancel the voting session, press: pound, eight, one.	#82	Chairperson
Ask a question To ask a question, press: star, two, two.	*22	Everyone
Cancel my question To cancel a question, press: pound, two, two.	#22	Everyone
Next in line question To let the next questioner ask a question, press: star, two three.	*23	Chairperson
End current question To terminate the current question, press: pound, two three.	#23	Chairperson
Cancel all questions To cancel all questions, press: star, two, four.	*24	Chairperson
Dial out to invitee To dial out to invitee, press: star, four.	*4	Chairperson
Admit invitee and continue dial-out To admit an invitee and continue dial-out press: star, one.	*1 (submenu)	Chairperson
Disconnect invitee and continue dial-out To disconnect an invitee and continue dial-out, press: star, two.	*2 (submenu)	Chairperson
Admit invitee and return to conference To admit an invitee and return to the conference, press: star, three.	*3 (submenu)	Chairperson
Disconnect invitee & return to conference To disconnect an invitee & return to conference press: star, four.	*4 (submenu)	Chairperson
Play Menu To play a new menu, press: star, eight, three.	*83	Everyone

Table 4-4: DTMF Operations Performed During Conference (Continued)

DTMF Function and Message	DTMF Code	Permission
Enable Roll Call To enable a Roll Call, press: star, three, two.	*32	Chairperson
Disable Roll Call To disable a Roll Call, press: pound, three, two.	# 32	Chairperson
Roll Call - review names To initiate the roll call and playback of the participant names, press: star, three, three.	*33	Chairperson
Roll Call - stop review names To end playback of participant names, press: pound, three, three.	#33	Chairperson
Start Dial Out To start the dial-out, press: star, two, five.	*25	Chairperson
Conference Termination To end the conference, press: star, eight, seven.	*87	Chairperson
Start Click & View To start the Click & View application, press: star, star.	**	Everyone
Change to Chairperson To change the status of a participant to Chairperson, press: star, seven, eight.	*78	Everyone
Increase my Broadcast volume To increase your volume, press: star, nine.	*9	Everyone
Decrease my Broadcast volume - To decrease your volume, press: pound, nine.	#9	Everyone
Increase my listening volume To increase your volume, press: star, seven, six.	*76	Everyone
Decrease my listening volume To decrease your volume, press: pound, seven, six.	#76	Everyone

Table 4-4: DTMF Operations Performed During Conference (Continued)

DTMF Function and Message	DTMF Code	Permission
<p>Override Mute All But Me* To enable participants to unmute their endpoints while the Exclusive Speaker Mute mode is imposed. * To enable this function, a DTMF code must be configured. These operations are listed and defined in the <i>IVR Service - DTMF Codes</i> dialog box. The same operations are also available from the MGC Manager application. For a description of the IVR Message Service setup, see Chapter 6, "IVR and Entry Queue Services".</p>		Everyone
<p>Start Recording Starts a recording session.</p> <p>Stop Recording Stops a recording session.</p> <p>Pause Recording Pauses a recording session.</p>	<p>*73</p> <p>*74</p> <p>*75</p>	<p>Chairperson</p> <p>Chairperson</p> <p>Chairperson</p>

Table 4-4: DTMF Operations Performed During Conference (Continued)

DTMF Function and Message	DTMF Code	Permission
<p>SilenceIT Menu The DTMF code to be used to play the SilenceIT menu. This code is used by the participant that who is muted due to a noisy line.</p>	9	Everyone
<p>Unmute and Return to Conference Unmutes and returns the participant to the conference.</p>	1	Everyone
<p>Return to Conference Muted Returns the muted participant to the conference while remaining muted.</p>	2	Everyone
<p>Adjust SilenceIT Sensitivity and Unmute Used by the muted participant to return to the conference unmuted while reducing the noise detection sensitivity. This option should be used if you do not want the system to identify a faint noise as a noisy line.</p>	3	Everyone
<p>Disable SilenceIT and Unmute Disables the SilenceIT option, unmutes the line of the participant who is placed on hold by the SilenceIT mode and returns the participant to the conference.</p>	4	Everyone

Using DTMF Codes in Cascading Conferences

During Cascaded conferences, the chairperson can control all the participants in the cascaded conference by performing the following tasks using DTMF codes:

- Set the chairperson as the conference's exclusive speaker while muting all the other conference participants
- Terminate the conference
- Lock or unlock the conference to undefine dial-in participants
- Secure a conference and release a secured conference
- Place the conference on-hold and reinstate the conference

If the chairperson uses any other DTMF codes, only the participants in the chairperson's local conference will be affected.

For more information on simple cascading, see the MGC Manager User's Guide, Volume II, Chapter 1.

For a detailed description of H.243 Cascading conferences, see the MGC Manager User's Guide, Volume II, Chapter 5.

Modifying Conference and Chairperson Passwords

During an On Going Conference, the Conference and Chairperson passwords can be modified by the chairperson or a participant (depending on the configured permissions) using DTMF codes from their endpoints (default DTMF code is *77). Passwords can also be modified by the operator via the MGC Manager. For more details, see "Modifying Conference and Chairperson Passwords" on page 4-68

When the chairperson activates the password modification process, the chairperson can select whether to modify the conference password or the chairperson password.

A sequence of voice messages and chairperson actions follows, to complete the password modification. Table 4-5 describes this sequence

If the chairperson or a participant exits without the password confirmation, the password is not updated.

Changing passwords is not permitted when a conference is in any of the following modes:

Table 4-5: Password Modification DTMF/IVR Sequences

User Action	IVR Message
Chairperson or participant enters the required "change password" DTMF code (1 or 2), or presses 9 to exit the menu.	"Press one to change conference password. Press two to change the chairperson password. Press nine to exit the menu".
Chairperson or participant enters 1 .	"Please enter the new conference password. Press the pound key to complete".
Chairperson or participant enters 2 .	"Please enter the new chairperson password. Press the pound key when complete".
Chairperson or participant enters 9 and exits the menu.	"Press nine to exit the menu".
Chairperson or participant enters the new password. Password confirmation request.	"Please re-enter the new password. Press the pound key to complete."
Chairperson or participant confirms the password. System confirms update.	"The password has been successfully changed".
While confirming the new password, chairperson or participant enters the existing password.	"The new password is invalid".

- Voting session
- Invite session
- Roll Call session
- Entry Queue with waiting participants

The default DTMF code for playing the appropriate Help menu is ***83**.

In an Entry Queue Access conference, both the conference and chairperson passwords must be unique and cannot be identical to any other conference that is accessed via the Entry Queue.

Request DTMF Help Menu

Participants in an Audio Only conference can request a playback of the list of all available operations and their assigned DTMF codes. The playback can be initiated by participants or the chairperson at any time during the conference by pressing the appropriate DTMF code. It can also be stopped at any time. This help menu is recorded by the conference provider as a voice message and is configured like any other voice message in the system. The Help menus follow the type of participants permission (chairperson or ordinary) and status:

- *Participant Help* – for ordinary participants
- *Chairperson Help* – for the conference chairperson
- *Voting Help* – for the participant controlling the voting session
- *Invite Help* – for the participant inviting others to the conference during an invite session

Dialing Out to Invite Participants (Invite Session)

In an Invite session, the chairperson in a conference can dial out and invite the called person to participate in the conference. This option is identical to the *Add New Participant* option available to the operator.



The Invite function is available to all participants when the permission to use this function is changed in the *IVR Service - DTMF Codes* dialog box. For more details about defining an IVR Service with DTMF codes enabled, see MGC Manager User's Guide Volume II, Chapter 2, Defining a New IVR Message Service.

To invite participants to join the conference:

1. Press ***4** on your touch-tone telephone to dial out to an individual.
You are moved to a side area and a dialing tone is heard.
2. Dial the number of the individual you want to invite and press the pound **<#>** key to start the dialing process.

If the invitee answered the call, you can do one of the following:

- Admit the invitee and continue dialing out to invite other individual by pressing ***1** on your touch-tone telephone.

- Disconnect the invitee and continue dialing out to invite other individual by pressing ***2** on your touch-tone telephone.
- Admit the invitee and return to the conference (thus ending the Invite session) by pressing ***3** on your touch-tone telephone.
- Disconnect the invitee and return to the conference (thus ending the Invite session) by pressing ***4** on your touch-tone telephone.

If the invitee did not answer the call, you can do one of the following:

- Disconnect the invitee and continue dialing out to invite other individual by pressing ***2** on your touch-tone telephone.
- Disconnect the invitee and return to the conference (thus ending the Invite session) by pressing ***4** on your touch-tone telephone.

Chairperson Initiated Blast Dial-out

Using the appropriate DTMF code, the chairperson or the participant (depending on the configured permission) can indicate to the system when to start the dial-out to multiple pre-defined participants.

This option prevents the system from automatically dialing out to pre-defined participants in a Meeting Room. The chairperson can indicate to the system to connect all predefined dial-out participants or to dial to individual dial-out participants by indicating their sequential order number in the list of participants defined for the conference.

In such a case, the chairperson enters the appropriate DTMF code followed by the participant number on the list. For example, if the DTMF code is ***25*** for blast dial-out, to instruct the system to dial to the third participant on the list, the chairperson enters ***253**. To instruct the system to dial-out to all predefined participants in one operation, the chairperson enters the DTMF code, for example **(*25*)**.

The DTMF code assigned to blast dial-out operation may be configured in the *IVR Message Service - DTMF Codes* dialog box. For more details, see Chapter 2.

Managing Secure Mode Conferences

In the Secure mode, joining the conference, monitoring or controlling the conference in any way, is denied to outside participants, including operators. However, operators can terminate the conference even in this mode. In addition, operators cannot view the participants list or any conference properties while the conference is in the Secure mode. Chairpersons can enable or disable the Secure mode for an On Going Conference, using the appropriate DTMF codes on the touch-tone telephone. While the conference is in a Secure mode, the chairperson and conference participants can perform various operations using the appropriate DTMF codes, such as voting or question-and-answer sessions. These operations will not be displayed in the MGC Manager monitoring panes. Once the chairperson secures or unsecures the conference, an appropriate voice message is played.



The voice message is played only if it is configured in the IVR Message Service and if the appropriate audio file has been downloaded to the Audio card.

In a secure conference, operator cannot perform the following actions:

- Join or attend the conference
- View and control the participants of the conference
- View and monitor the conference properties
- Implement Voting
- Initiate an Invite session

Roll Call

When the Roll Call option is enabled in the IVR Service assigned to the On Going Conference, the chairperson can request the system to play the names of all connected conference participants at the beginning of the conference, or at any time during the conference. The IVR system then plays the recorded list of conference attendees, one after the other, in the order that they entered the conference. The recordings are played to all the conference participants.

Roll Call Guidelines

- The Roll Call Confirmation message is not played to the participant when the flag in the “system.cfg” `ROLL_CALL_CONFIRMATION =`

YES (default) is set to NO.

- Roll Call is not supported with the Guidance feature or when the participant is moved from the Operator conference (attended status) to the Home Conference.
- Roll Call is not supported when the participant is moved from one conference to another. The participant name is not announced when the participant leaves the first conference and enters the second conference.
- Roll Call is not supported with the Invite feature. When a participant is invited to the conference by the chairperson, the invitee name is not recorded and therefore not announced when the participant enters or leaves the conference or during the Roll Call.

Table 4-6 lists the Roll Call actions and the corresponding DTMF codes.

Table 4-6: Roll Call DTMF Options

Operation	Default DTMF Code	Description
<i>Enable Roll Call</i>	*32	Enables the Roll Call feature for the conference.
<i>Disable Roll Call</i>	#32	Disabled, the Roll Call feature for the conference. However, participants names are still recorded in case the Roll Call feature will be enabled later, during the conference.
<i>Roll Call Review Names</i>	*33	Requests to play the recorded names of the participants connected to the conference, one after the other, in the order in which they entered the conference.
<i>Roll Call Stop Review Names</i>	#33	When requested, the system stops the Roll Call playback.

Meeting Rooms and Entry Queues

Meeting Rooms are used for on demand conferencing. Entry Queues are a single-dial lobby for routing participants to their target conferences without having to allocate dial-in numbers to each conference or Meeting Room. Entry Queues are also used for Ad Hoc conferencing to start On Going Conferences without prior scheduling. This chapter describes the definition of Meeting Rooms and single-dial Entry Queues that are used for routing participants to their destination conferences.

Meeting Rooms

Meeting Rooms are conferences that have no allocated resources on the MCU or a starting date and time. They are created once but remain on the MCU in Passive mode and can be activated as many times as required. When the conference ends, the conference reverts to the passive Meeting Room mode until the next activation. It remains in the MCU memory (configuration) and is displayed in the Meeting Rooms list. For a detailed description of Ad Hoc Conferencing, see, MGC Manager User's Guide, Volume II, Chapter 3, "Ad Hoc Conferencing and External Database Authentication".

The Meeting Room is activated when the first participant connects to it. The conference connection information is given to all other participants by the Meeting Room owner. The Meeting Room is terminated when the last participant disconnects from the conference or when the chairperson leaves the conference, depending on the conference settings. However, Meeting Rooms can be manually terminated at any time by the MGC Manager operator, or by the conference chairperson via the WebCommander or by using the appropriate DTMF code.

Meeting Rooms can be defined in the MGC Manager and in the WebCommander application.

The ISDN/PSTN/T1-CAS dial-in numbers allocated to a Meeting Room can be automatically allocated by the MCU based on the dial-in numbers allocated to it by the carrier or manually during the Meeting Room definition.

Once the Meeting Room is saved on the MCU, the conference chairperson or the first participant who dials into the conference automatically activates it. Other participants can join the conference by dialing in to it. If dial-out participants are also defined for this conference, the system automatically dials out to these participants when the conference is activated. The operator or conference chairperson can lock the conference to additional dial-in participants at any time. When the conference is terminated, the system checks the Meeting Room recurrence settings. If the Meeting Room is still valid for re-activation, the Meeting Room remains inactively in the system, waiting for another initiating call. Otherwise, the Meeting Room is deleted from the system when the conference ends. An operator can delete the Meeting Room through the MGC Manager to prevent its re-activation.

The number of Meeting Rooms is limited to about 2000. If you need more than this, you can use Ad Hoc conferencing which enables you to instantly start and connect to multipoint conferences from your endpoint without prior reservation or scheduling. For more details about Ad Hoc conferencing, see MGC Manager User's Guide, Volume II, Chapter 3, "Ad Hoc Conferencing and External Database Authentication".

Entry Queues

An Entry Queue is a special routing lobby to which one or several dial-in numbers are assigned. Participants are guided by voice prompts which are part of the Entry Queue Service to connect to this lobby and are routed to their destination conferences according to the conference Numeric ID or password that they enter using touch-tone signals (DTMF codes). Entry Queues remain in a passive state when there are no participants in the queue and they are automatically activated when a participant dials the Entry Queue number.

The Entry Queue makes it possible to use a limited number of PSTN/ISDN/T1-CAS dial-in numbers for all the conferences and to use toll-free numbers for conferences which are charged to the meeting organizers.

Entry Queues that were defined for video conferencing can also be used for Audio Only conferences, provided that the audio algorithm is set to G.711 (telephone standard). This means that there is no need to define separate Entry Queues for Audio Only conferences. However, if the VTX 1000

endpoints are used for conferencing, a separate Entry Queue must be defined to allow participants to maintain high the audio quality.

For more information on Entry Queue Service definition, see “Defining a New Audio Only Entry Queue” on page 5-13.

A conference may be accessed by dial-in participants directly or through an Entry Queue.

If you are defining a conference that is accessed through an Entry Queue, you do not need to define the Meet Me Per Conference parameters.

Participants can be moved from the Entry Queue to a target conference that has the same line rate and media settings. In audio conferences, the audio algorithm may be different when IP Only participants connect to the Entry Queue, or when the VTX 1000 endpoint is used.

Defining a New Audio Only Meeting Room

To define a new Meeting Room:

1. Expand the MCU tree.
2. Right-click the *Meeting Rooms* icon, and then click **New Meeting Room**.

The *Conference Properties - General* dialog box opens.

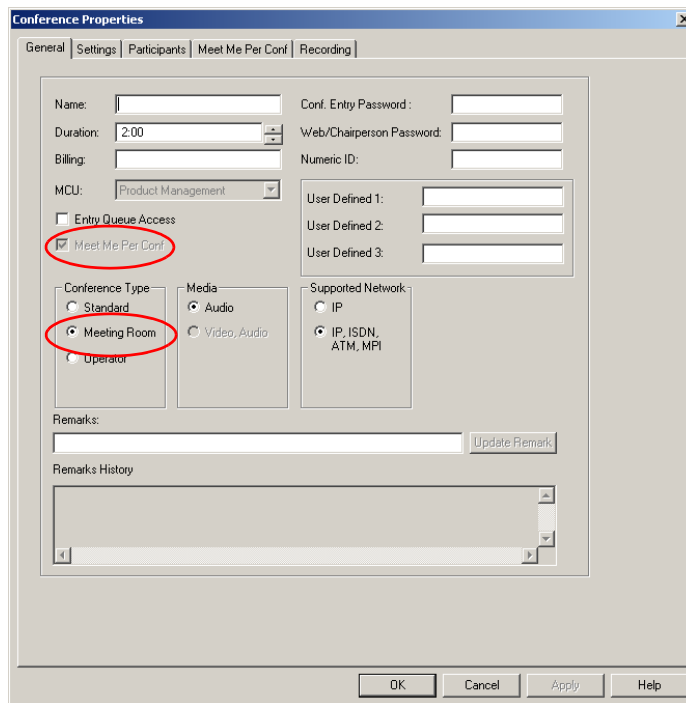

The *Conference Type* is automatically set to *Meeting Room* and the *Meet Me Per Conference* option is selected (and cannot be cleared). The *Meet Me Per Conf* tab is included in the *Properties* dialog box.

3. Define the conference general parameters, such as name, Numeric ID, passwords and duration or use the system defaults for the conference duration and passwords (if the MCU is configured to automatically allocate passwords). For detailed description of these parameters, see Chapter 2, "Defining New On Going Audio Conferences" on page 2-14.

4. Click the **Settings** tab.
The *Conference Properties - Settings* dialog box appears. These parameters are identical to the standard conference Settings parameters.
5. Define the *Settings* parameters, as described for the definition of On Going Conferences. For more information, see Chapter 2, "Settings Parameters" on page 2-21.
6. Click the **Participants** tab to add defined participants (mainly dial-out) either from a template or to define a new participant.
7. Define the conference *Participants* parameters as described in the definition of new On Going Conferences. For more information, see Chapter 2, "Participants" on page 2-28.

Meeting Rooms usually include undefined dial-in participants, therefore there is no need to predefine the parameters and capabilities of each endpoint/telephone - the participants are automatically detected by the MCU. Access this tab if you want to define the number of participants for which the system should save resources and the maximum number of participants allowed to connect to this conference.



If the *Max Participants* option is set to *Auto*, the number of participants that can connect to the conference is limited by the availability of MCU resources.

- Click the **Meet Me Per Conf** tab.
The *Meet Me Per Conf* dialog box opens.

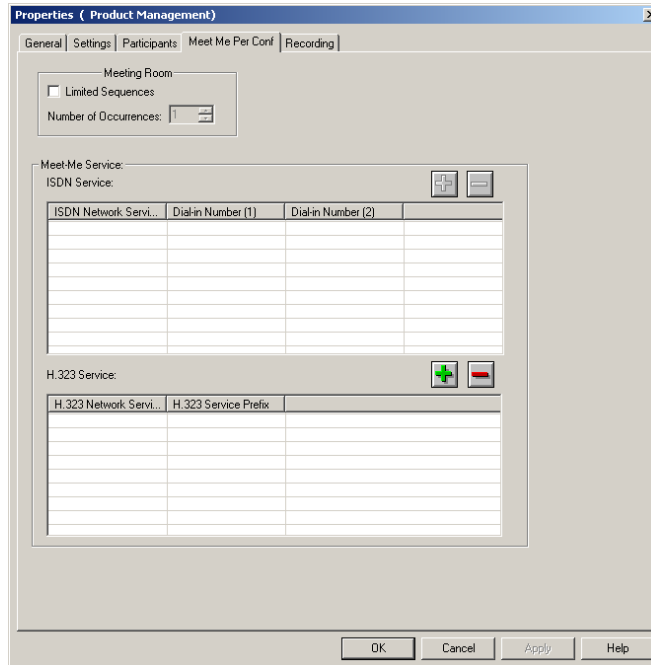

The *Meet Me Per Conference* option allows participants to connect to a conference by simply dialing a pre-defined conference number.

Up to 16 ISDN/PSTN/T1-CAS dial-in numbers (usually one or two phone numbers) can be assigned to the conference. Participants must dial one of these numbers to automatically connect to the appropriate conference.





If you intend to manually allocate a dial-in number to the conference, you can check the ISDN/T1-CAS Network Service for the dial in numbers that can be allocated to conferences.



This tab appears only if the Meet Me Per Conf option is selected in the General tab. If the Entry Queue Access is selected for the conference, and you are using the system defaults, you do not need to select this option.

9. Define the following Meeting Room parameters:

Table 5-1: Meeting Room Properties - Meet Me Per Conf

Field/Option	Description
<i>Limited Sequences</i>	Select this option to limit the number of times that the Meeting Room can be activated. If this check box is cleared, the number of activations is unlimited, and the Meeting Room can be saved on the MCU indefinitely or until it is deleted from the MCU.
<i>Number of Occurrences</i>	This option is enabled when the <i>Limited Sequences</i> option is selected. Define the number of times the Meeting Room will be activated. You can choose any number of Meeting Rooms activations. 0 means that the conference has an unlimited number of activations and can be in sleep mode (passive) forever. 1 means that the conference will be activated once, and then it will be deleted from the system. 2 or more means that the conference will be activated twice or more, and the conference will remain in sleep mode (passive) in between recurrences.
<i>ISDN Service</i>	Displays the ISDN Network Service Name and dial-in numbers assigned to the Meeting Room. Note: T1-CAS Network Service name and dial-in numbers are also displayed in this section. Click the plus  button to add dial-in numbers to the ISDN Network Service and the minus  button to remove dial-in numbers from the ISDN Network Service. For more details, see "Manually Assigning Phone Numbers to the Conference" on page 5-8.
<i>H.323 Service</i>	Displays the IP (H.323) Network Service Name and the H.323 Service Prefix assigned to the Meeting Room. Click the plus  button to add dial-in numbers to the IP (H.323) Network Service and the minus  button to remove dial-in numbers from the IP (H.323) Network Service. For more details, see "Manually Assigning the H.323 Service Prefix to the Conference" on page 5-10.

To define Meet Me ISDN/T1-CAS Services:

The conference dial-in phone number can be assigned by the operator, or automatically by the system. This number is then given to all participants who will be connecting to that conference.

A single dial-in number that is allocated by the system when the Meeting Room is saved on the MCU, is derived from the dial-in numbers defined in the ISDN or T1-CAS Network Service. The phone number assigned by the system can be viewed in the *Status* pane of the MGC Manager window, or when checking the Meeting Room properties.

The list of dial-in numbers assigned to the Meeting Room is displayed in the Meet-Me Services table. The first column displays the ISDN Network Service name. The Phone 1 and Phone 2 columns display the first and second phone numbers assigned to the conference.



You can add T1-CAS dial-in numbers in the same way as ISDN numbers - the T1-CAS numbers are listed under the ISDN Network Service.

To do so, the MCU must be first configured to allow T1-CAS participants. The appropriate flag has to be set in the *system.cfg* file and a T1-CAS Network Service has to be defined in the system. For more information, see the MGC Administrator's Guide, "Defining a T1-CAS Network Service".

If participants in the same conference use different Network Services (such as two different ISDN Services, or an ISDN and T1-CAS Service), the Meeting Room can be assigned different phone numbers for each of the Network Services used by the participants to connect to the conference. In that case, use the manual allocation method.



If no dial-in number is defined, the system assigns the MCU number defined in the ISDN Network Service. If there is no number defined for the MCU in the ISDN Network Service, the system allocates the first free number in the dial-in numbers range defined in the ISDN Network Service.

Manually Assigning Phone Numbers to the Conference

10. To manually assign a phone number to the conference in the *ISDN Service* pane, click the plus  button.

The *Meet Me Service* dialog box opens.

- a. Define the following parameters:

Table 5-2: *Meet Me Service Options*

Option	Description
<i>Service Name</i>	Enter the name of the ISDN Network Service or the T1-CAS Network Service to be used by participants to connect to the conference exactly as it is defined in the <i>Network Services</i> list (the system is case sensitive).
<i>Dial-in Number (1)</i>	Enter the first dial-in number to be assigned to the conference. This number must be defined in the dial-in numbers range defined for the selected ISDN Network Service or the T1-CAS Network Service. For more details regarding the dial-in numbers range, see the MGC Administrator's Guide, Chapter 3. Note: When connecting ISDN lines via a private PBX to the MCU, the PBX may truncate the dialed numbers. In that case, the dial-in numbers defined in the ISDN Network Service may include only part of the dialed string. The operator must add the truncated digits to the dial-in number conveyed to the participant.
<i>Dial-in Number (2)</i>	Enter the second dial-in number to be assigned to the conference. This number is optional.

- b. Click **OK**.
The dial-in range is added to the *ISDN Service* table. Repeat the above steps to define additional dial-in numbers.



Use the same procedures when manually adding and removing T1-CS dial-in numbers.

Manually Assigning the H.323 Service Prefix to the Conference

To assign the H.323 Service Prefix to the conference:

The H.323 Network Service Prefix is part of the dialing string entered by H.323 dial-in participants.

H.323 participants can dial-in to a conference defined as *Meet Me per Conference* or Meeting Room by dialing the H.323 Network Service Prefix and the Numeric ID of the conference.

- 11. To manually add an H.323 Network Service Prefix to the conference, in the *H.323 Prefix Service* pane click the plus [+] icon.
The *H323 Service* dialog box opens.

- a. Define the following parameters:

Table 5-3: H.323 Network Service Parameters

Field/Option	Parameter
<i>H.323 Network Service Name</i>	Enter the name of the IP Network Service that contains the prefix to be used by participants connecting to the conference.
<i>H.323 Service Prefix</i>	Enter the Network Service prefix as defined in the <i>IP Network Service Properties - H.323</i> dialog box.

If required, repeat these steps to define additional prefixes.

- b. Click **OK**.

Completing the Meeting Room Definition

12. Click **OK** to complete the Meeting Room definition.

The new Meeting Room is added to the Meeting Rooms list. Once the Meeting Room is activated, it becomes an On Going Conference and it is listed under the *On Going Conferences* list.



The Meeting Room will fail to start if the dial-in number allocated to the Meeting Room is in use by another reserved conference, or if the MCU has run out of resources.

Listing Meeting Rooms

Meeting Rooms are listed under the *Meeting Rooms* category in the MCU list.

To view the Meeting Rooms list in the Browser pane:

1. In the *Browser* pane, expand the *MCU* tree.
2. Expand the *Meeting Rooms* tree.
The system displays the list of the Meeting Rooms.

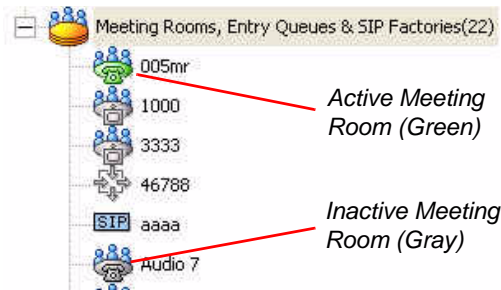

The number of Meeting Rooms and Entry Queues currently defined for this MCU appears in brackets next to the *Meeting Rooms* icon.

Active Meeting Rooms are displayed in green. Inactive Meeting Rooms are displayed in gray.

To view the Meeting Rooms list in the Status pane:

You can also view the list of Meeting Rooms in the *Status* pane. This enables you to easily retrieve the Numeric ID, passwords, dial-in numbers and H.323 Network Service Prefix assigned to the Meeting Room. This is especially

useful when the dialing parameters were automatically allocated by the system.

- In the *Browser* pane, in the MCU tree, click the *Meeting Rooms* icon.

The Entry Queues and Meeting Rooms are listed in the *Status* pane.

Name	Status	Duration	ID	Dial-in Number	Entry Password	Chairperson Password	Numeric Id	H323 Service Prefix
005mr	O.K.	02:00:00	246	2284	276252	097603	5555	871
1000	O.K.	02:00:00	199		267161	271781	1000	87
3333	O.K.	02:00:00	207		107842	055960	2324	871
46788	O.K.	02:00:00	177	2285	046692	295591	1471	95
aaaa	O.K.	02:00:00	238		001702	006960	2949	
Audio 7	O.K.	02:00:00	233	2298	130261	1234	5678	871

The system displays the dial-in number, entry and Chairperson passwords, conference Numeric ID and the H.323 Network Service prefix of the Meeting Room in the respective columns.

Defining a New Audio Only Entry Queue

To define a new Audio Only Entry Queue:

1. Connect to an MCU and expand its tree.
2. If you are not using the Entry Queue Service shipped with the software, and if you have not already done so, define the Entry Queue Service. For more details, see Chapter 6, “Defining a New Entry Queue Message Service” on page 6-40.
3. Right-click the *Meeting Rooms* icon, and then click **New Entry Queue**.



The *Entry Queue Properties* dialog box opens.

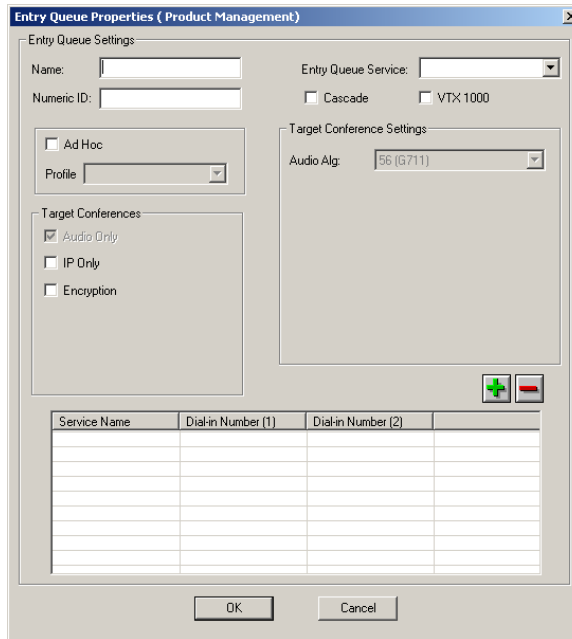

4. Define the following parameters:

Table 5-4: Audio Only Entry Queue Properties

Field/Option	Description
<i>Name</i>	Enter the name of the Entry Queue using up to 80 characters. Note: An error message is displayed when saving the Entry Queue if the name is used in any other conference, Meeting Room or Entry Queue on the same MCU.

Table 5-4: Audio Only Entry Queue Properties (Continued)

Field/Option	Description
<i>Numeric ID</i>	<p>A Numeric ID (NID) is a unique number that identifies the Entry Queue to the system. This number is used by H.323 endpoints to connect to the Entry Queue. Numeric IDs are assigned manually or automatically.</p> <ul style="list-style-type: none"> • To manually assign the Numeric ID, enter a number containing the number of digits defined in the system.cfg file. If the same Numeric ID is already in use in another Entry Queue or conference, an error message is displayed when the Entry Queue is saved on the MCU. • To automatically assign the Numeric ID, complete the Entry Queue definition. The MCU assigns a unique Numeric ID automatically when the new Entry Queue is saved on the MCU. <p>Note: If the MCU is configured to support only the automatic assignment of Numeric IDs, this field is disabled and the system automatically assigns a Numeric ID after you save the new Entry Queue on the MCU.</p>
<i>Entry Queue Service</i>	<p>Select the Entry Queue Service that will be used to play audio messages and prompts to participants waiting in the Entry Queue. Leave this field blank to use the default Entry Queue Service (if an Entry Queue Service was set as default).</p> <p>Note: The system is case sensitive.</p>
<i>Cascade</i>	<p>Select this check box to define an Auto Cascade Entry Queue.</p> <p>Defining an Auto Cascade Entry Queue is part of the setup process to enable automatic cascading of Ad Hoc conferences. For details see the MGC Manager User's Guide, Volume II, Chapter 3, "Ad Hoc Auto Cascading".</p>

Table 5-4: Audio Only Entry Queue Properties (Continued)

Field/Option	Description
<i>VTX 1000</i>	<p>Select this check box to create a VTX 1000 enabled Entry Queue.</p> <p>Participants connecting to VTX 1000 enabled Entry Queues are initially assigned wide band resources. If the endpoint is not identified as VTX, the wide band resources are subsequently released.</p>
<i>Ad Hoc</i>	<p>Select this option to enable Ad Hoc conferencing. When selected, an Ad Hoc conference to be created, based on the Profile that was assigned to the Entry Queue.</p> <p>For a detailed description of Ad Hoc options and definition, see MGC Manager User's Guide, Volume II, Chapter 3, "Ad Hoc Conferencing and External Database Authentication".</p> <p>Note:</p> <ul style="list-style-type: none"> • You cannot select the Ad Hoc option if no Profile is defined in the system. • The Ad Hoc Entry Queue can also be used for access to standard conference. In that case, the Target Conference Settings defined in the Entry Queue are used for connecting participants to the Entry Queue.
<i>Profile</i>	<p>Select the profile to be used for the definition of the target conference in Ad Hoc conferencing.</p> <p>Note: For more details about Profile definition, see the MGC Manager User's Guide, Volume II, Chapter 3, "Profiles".</p>
<i>Target Conferences</i>	<ul style="list-style-type: none"> • Audio Only – Select this option for an Audio Only Entry Queue. If <i>Audio Look & Feel</i> mode is selected, it is the default setting. • IP Only – Select this option to allow only VoIP participants to connect to this Entry Queue. • Encryption – (applicable with IP Only) Select this option to enable only encrypted participants to connect to the Entry Queue.

Table 5-4: Audio Only Entry Queue Properties (Continued)

Field/Option	Description
<i>Target Conference Settings</i>	Audio Alg – If <i>IP Only</i> is selected, you can select the audio algorithm to use for the VoIP participants connecting to the Entry Queue. This must be the same audio algorithm used in the target conference.
<i>Entry Queue Dial-in Numbers</i>	Lists the numbers to be dialed by the PSTN/ISDN/T1-CAS dial-in participants connecting to the Entry Queue. This table is disabled when defining an IP Only Entry Queue. If this table is left empty, the MCU automatically assigns the dial-in number.

Enabling Encryption for Entry Queues

To be able to join a conference from an Entry Queue as an encrypted participant, the Entry Queue must be encrypted. All non-encrypted participants connecting to this Entry Queue are disconnected from the MCU.

Encrypted participants can be moved from an encrypted Entry Queue to the destination conference depending on the destination conference settings and the setting of the participant level flag in the system.cfg file:

- If the target conference is encrypted, and the participant level flag is set to **YES**, encrypted and non-encrypted participants can join the target conference. In such a case, participants from an encrypted Entry Queue and from non-encrypted Entry Queue can join the encrypted conference.
- If the target conference is encrypted, and the participant level flag is set to **NO**, only encrypted participants can join the target conference. In such a case, participants from an encrypted Entry Queue can be moved to the target conference.
- If the target conference is not encrypted, and the participant level flag is set to **YES**, encrypted and non-encrypted participants can join the target conference. In such a case, participants from an encrypted Entry Queue and from non-encrypted entry queue can join the non-encrypted conference.
- If the target conference is not encrypted, and the participant level flag is set to **NO**, only non- encrypted participants can join the target conference.

To manually assign Dial-in numbers to the Entry Queue:

The dial-in phone numbers are assigned to the Entry Queue manually by the operator or automatically by the system. These numbers are then communicated to the callers who connect to the conference.

The dial-in numbers assigned to the ISDN Entry Queue are listed in the Dial-in Numbers table. The first column displays the Network Service name. The Phone 1 and Phone 2 columns display the first and second phone numbers assigned to the Entry Queue.

If participants in the same Entry Queue use different Network Services (such as two different ISDN services, or an ISDN and T1-CAS service), the conference can be assigned different phone numbers for each of the Network Services used. In that case, the manual allocation method is used.



- Up to 16 dial-in phone numbers can be assigned to the Entry Queue.
- If no dial-in number is assigned for this Entry Queue, the system automatically assigns one, using the dial-in numbers defined in the ISDN/PSTN/T1-CAS Network Service.

5. Click the plus  button.

The Meet Me Service dialog box opens. For instructions how to assign phone numbers to the conference, see “Manually Assigning Phone Numbers to the Conference” on page 5-8.

To delete an ISDN/PSTN/T1-CAS Network Service from the Entry Queue:

- a. Select the service name or phone number to delete.
 - b. Click the minus  button in the Entry Queue dialog box. The service name and its phone numbers are deleted.
6. Click **OK** to complete the Entry Queue definition. Entry Queue is added to the Meeting Rooms, Entry Queues & SIP Factory list. Usually only a limited number of Entry Queues are defined in order to save dial-in numbers.

Listing Entry Queues

To view the list of Entry Queues in the Browser pane:

- In the *Browser* pane of the main window, expand the *MCU* tree and then expand the *Meeting Rooms, Entry Queues and SIP Factories* tree. The Meeting Rooms and Entry Queues currently defined for the MCU are listed with the total number displayed in brackets next to the icon.

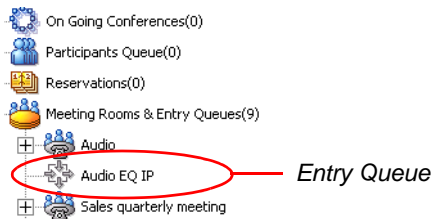

The Entry Queues and Meeting Rooms are listed in the *Status* pane.

To view the list of Entry Queues in the Status pane:

- Click the *Meeting Rooms, Entry Queues and SIP Factories* icon. The Meeting Rooms and Entry Queues are listed in the *Status* pane.

Name	Status	Duration	ID	Numeric Id	Dial-in Number	Entry Password	Chair Password	H323 Service Prefix
123	O.K.	02:00:00	44	2603	9215184	12345	1111	1719
MR 1	O.K.	02:00:00	54	3496	9215189	021228	021477	1719
MR 2	O.K.	02:00:00	55	4258				1719
Sales	O.K.	02:00:00	68	8108	9215180	22222	11111	1719
Transitions	O.K.	02:00:00	70	3077	9215179	986578	342654	1719

This view enables you to easily retrieve the dial-in numbers and the Numeric IDs assigned to the Entry Queue. This is especially useful when the dial-in numbers and Numeric IDs were automatically allocated by the system.

Dialing in to an Entry Queue

PSTN Phone / Cellular Phone / ISDN / T1-CAS endpoint participants

To access the Entry Queue from a PSTN phone/cellular phone or an ISDN endpoint (or Video endpoint connecting as Audio Only) participants can use the dial-in number assigned to the Entry Queue.

H.323 Participant:

H.323 participants connect to an Entry Queue by dialing the H.323 Network Service Prefix and the Entry Queue Numeric ID or name.

[H.323 Network Service Prefix][EQ Numeric ID]

For example, if the H.323 Network Service prefix is 100, the Entry Queue Numeric ID is 1122, and the Entry Queue name is POLYCOM, the participant dials 1001122 or 100POLYCOM. Upon connection to the Entry Queue, they are routed to the destination conference in the same way as ISDN/PSTN/T1-CAS participants.

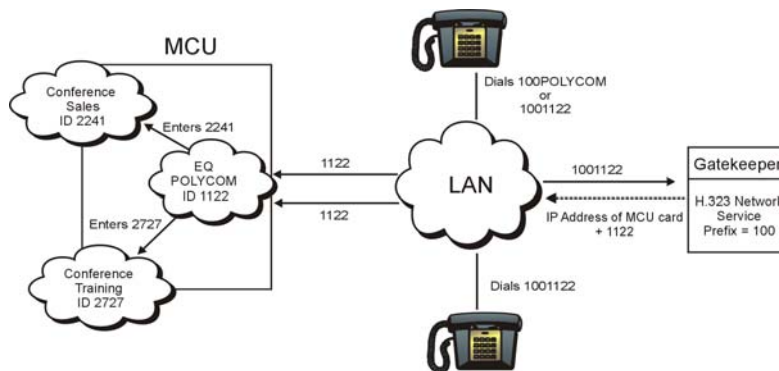

H.323 participants can also bypass the Entry Queue voice messages and the conference IVR messages by adding the correct Numeric ID of destination conference and, if necessary, *Conference Entry Password* to the initial dial string:

- To be routed directly to the conference, add the Numeric ID of the destination conference to the dial string:

[Network Service Prefix][EQ Numeric ID] [##Destination Conference Numeric ID#]

For example, if the H.323 Network Service prefix is **23**, the Entry Queue ID is **1122** and the destination Conference ID is **2241**, the dial string is **1001122##2241#**.

- To be routed directly to the conference and bypass the Entry Queue and the conference IVR queue, add the Conference Entry password, enclosed by pound signs, to the dial string:

[Network Service Prefix][EQ Numeric ID] [##Destination Conference Numeric ID#[#Password#]

For example, if the Network Service Prefix is **100**, the Conference Numeric ID of the Entry Queue is **1122**, the Conference Numeric ID of the destination conference is **2241** and the Conference Entry Password is **4444**, the dial string will be **1001122##2241##4444#**.

IVR and Entry Queue Services

The Interactive Voice Response (IVR) application is a service that allows participants to communicate with the conferencing system over the telephone or an endpoint. The IVR Service includes a set of voice prompts that allow support of multiple languages and user-specific voice prompts. This set is activated when a participant connects to the Polycom VoicePlus conferencing system for conference access or when certain events occur during the conference, such as voting sessions, Q&A sessions, requests for Operator assistance and modifying self volume.

The IVR Service automates the connection to the conference process and enables the participant to perform various operations during the conference. By combining the input of the caller with menu-driven scripts, participants can call the conference dial-in number and use a touch-tone telephone or the endpoint's remote control, to interact with the conferencing system.



- The system is shipped with a default IVR Service that can be automatically installed in the MCU, or manually, by means of the Restore Configuration utility. For details, see the *MGC Administrator's Guide, Chapter 2, Manual Installation of the Default Message Services*.
- Up to 30 IVR Services may be defined for a single MGC unit.

The Entry Queue Service is a subset of the IVR Service, and it can be used in conjunction with IVR for routing dial-in participants. Entry Queue is a call routing method in which all participants dial the same dial-in number and then are routed to the appropriate conference by entering the conference password or conference numeric ID, depending on the system's configuration. Callers are guided to the conference using menu-driven scripts that are part of the Entry Queue Service. The user inputs touch-tone signals in response to voice prompts.

Conference Access

Dial-in participants can access the conference by using the following connection methods:

- Directly
- By means of the IVR Service
- By means of the Entry Queue

Directly

No IVR Service is assigned to the conference. The participants dial the conference dial-in number or string and connect directly to the conference. In this case, the functionality provided by the IVR Service is unavailable.

IVR Queue Access

Participants dial the conference dial-in numbers and are connected to the conference IVR queue. Using the telephone or endpoint, keypad, participants input the required information to menu driven scripts and voice prompts that are part of the IVR Service. Once the correct information is entered, the callers are connected to the conference.

You can define a range of IVR Services, and customize the menu-driven scripts and voice prompts to meet different needs or languages. The IVR Services are assigned at the conference level, and different conferences may use different IVR Services, or the same IVR Service may be used for all conferences.

Entry Queue Access

Entry Queue is a call routing method in which all participants dial the same dial-in number. Participants are guided to the conference using menu-driven scripts that are part of the Entry Queue Service. Using the telephone or endpoint keypad, participants enter the required details of the target conference and are then connected to that conference.

IVR Services can also be assigned to the target conference that are accessed from the Entry Queue. In that case, the participants are moved from the Entry Queue to the conference IVR Queue.

For a detailed description and examples how to connect and join conferences using IVR and Entry Queue services, see Chapter 2, “Conference Access for Dial-in Participants” on page 2-8.

IVR/Entry Queue Stages

Participants in a conference using IVR for connecting automatically to the conference and for control functionality can be in one of the following statuses:

- *Greeting* - the participant connects to the MCU, enters the IVR queue, and hears the audio messages of the menu. If an Entry Queue is used for conference access, the greeting stage may be made up of two steps: general greeting in the Entry Queue and individual greeting in the IVR queue when connecting to conference.
- *Conferencing* - the participant is connected to the conference.

In attended conferences, two additional stages are available: *Attended* and *On Hold*. *Attended* status indicates that the participant is being assisted by the operator in an Operator Conference. *On Hold* status indicates that the participant was placed on hold and hears background music while waiting for the operator.

If not set otherwise, the participant is automatically moved from the queue (Greeting stage) to the conference (Conferencing stage).

If an Entry Queue is used in conjunction with an IVR Service assigned to the conference, the caller is automatically transferred from the Entry Queue to the IVR Service. If not set otherwise, the participant is automatically moved from the IVR (Greeting stage) to the conference (Conferencing stage).

Operations Performed Using IVR Services

In IVR-enabled conferences, various operations can be performed by the operator or the conference chairperson. These operations are available only when an IVR Service is assigned to the conference. The IVR software module enables the operator to perform the following operations using the MGC Manager application or the MGC WebCommander application. These operations are described in Chapter 7, Attended Conferencing.

The IVR software module enables participants and the conference chairperson to perform the following operations from their endpoints using DTMF codes. For a list of default DTMF codes, see Chapter 4, “Managing Conferences Using DTMF Codes”.

Table 6-1: DTMF Enabled Actions and Permissions

DTMF Enabled Action	Permission
Request personal assistance	Everyone
Play the help menu	Everyone
Start and stop recording	Chairperson
Adjust the participant's broadcasting and listening volume	Everyone
Change the participant's status to Chairperson	Everyone
Lock or unlock a conference to dial in participants	Chairperson
Request assistance for conference	Chairperson
Secure or unsecure a conference	Chairperson
Mute all participants except the requesting participant	Chairperson
Cancel the <i>Mute All</i> mode	Chairperson
Enable or disable the SilenceIT feature	Chairperson
Adjust SilenceIT sensitivity	Chairperson
Change the conference password	Chairperson
Place the conference on-hold and reinstate it	Chairperson
Mute "Meet Me" participants upon their connection to the conference	Chairperson
Manage Question-and-Answer sessions	Chairperson
Enable or disable the Roll Call feature	Chairperson
Request a Roll Call	Chairperson
Stop the Roll Call names review	Chairperson
DTMF Enabled Cascading	Chairperson
Invite other participants to join the conference	Chairperson
End the Conference	Chairperson

Using Roll Call

The Roll Call feature is used in IVR Message Service to record the participants name and play it back when entering and leaving a conference. The purpose of Roll Call is to ensure that all required participants are present, and to identify the participants to one another.

Participants connecting to the conference are asked to record their names. The system records the names and plays the recorded names when the participants enter and leave the conference. During an IVR enabled conference, the chairperson can request the system to play the names of all connected participants at the beginning of the conference or at any time during the conference. The IVR system plays the recorded list of conference attendees, one after the other, in the order that they entered the conference. The recordings are played to all the conference participants.

The basic Roll Call contains the following stages:

1. Participants connect to the conference, and are requested to record their names.
2. Participants record their names. The recording is automatically terminated after two seconds.
3. The system plays the recorded name to each participant and asks the participant to press a pre-configured key for confirmation. The participant may alternatively record the name again.



Playing the Roll Call Confirm Record message to participants is optional. The Roll Call Confirmation message is not played to the participant when the flag `ROLL_CALL_CONFIRMATION = YES` (default), located in the Greet&Guide/IVR section of the "system.cfg" is set to **NO**.

4. Once the participants confirm the recording, the system connects them to the conference and announces their names to the connected participants.
5. During the conference, the chairperson can request a roll call using the appropriate DTMF code from the endpoint's input device. When the system plays back the participant names, all conference participants get to hear it using the appropriate DTMF codes. The chairperson can end the Roll Call playback at any time.

6. When a participant leaves or is disconnected from the conference, participants remaining in the conference hear an audio message announcing the name of the participant who has left the conference.

Roll Call can be activated during different conference statuses:

- **Conference On Hold**
Participants who access a conference that was placed on hold, must follow the usual connection process and record their names. However, when participants enter conferences on hold, their names are not played to the conference. The chairperson can request a roll call only when the conference is reinstated and the on hold state is revoked. The list of played names will then include the participants who connected to the conference while it was on hold.
- **Admittance during a Roll Call**
When participants join or leave the conference during an on going Roll Call, the corresponding announcement is played immediately, thereby interrupting the on going Roll Call. When the Roll Call is resumed, the name of the participant who left the conference is skipped (not played).
- **No Other Participants Indication**
When the chairperson asks for a Roll Call and there are no other participants in the conference at that time, only the chairperson's name will be played.

Enabling Roll Call

Roll Call must be enabled or disabled at the conference level by assigning a Roll Call enabled IVR Service and by enabling it in the *Conference Properties- Settings* dialog box. However, if the Roll Call option is not enabled in the IVR Message Service, it cannot be activated for the conference.

For more details on enabling Roll Call during a conference and a list of Roll Call DTMF options, see Chapter 4, "Roll Call".

Using SilenceIT

The SilenceIT feature (automatic muting of detected noisy lines) is used in conferences that were assigned an IVR Message Service to control and ensure the quality of the audio transmission for the conference participants. When the system detects a noisy line and mutes it, an IVR message is played to inform the conference participants that one of them was muted due to their

noisy line. At this point, the muted participant can press <9> to listen to a menu which lists the following options:

- Return to the conference unmuted (default)
- Return to the conference muted
- Reduce the level of the SilenceIT Sensitivity and return to the conference unmuted
- Disable the SilenceIT feature for this conference and return to the conference unmuted

For IVR messages used with SilenceIT, see Table 6-10 on page 6-33.

- SilenceIT is supported for Audio Only participants in IVR-enabled Audio and Video conferences.
- SilenceIT is not supported when the participant is moved to the Operator Conference (Attended status).
- SilenceIT is not supported in Recording Ports and with DTMF Forwarding.
- SilenceIT is not applicable with Cascading conferences.

Enabling SilenceIT

Enabling the SilenceIT option for an IVR Service is described on page 6-16.

The SilenceIT option is enabled for conferences by assigning a SilenceIT-enabled IVR Service and by selecting his option in the *Conference Properties - Settings* dialog box. However, if the option is not enabled in the IVR Message Service, it cannot be activated for the conference. If you enable this option while an IVR Service you selected as the Message Service type is not SilenceIT-enabled, the conference definition will be rejected.

IVR Requirements

Appropriate hardware and audio files are required for the IVR system.

Hardware

The following hardware is required to set up and manage IVR conferences:

- **Audio+ card** - The Audio+ card stores the audio messages that are part of the IVR Service. These messages are played while the participants wait in an IVR-enabled Entry Queue, Participants Queue or conference.
- **Music I/O card** (optional) - An I/O card attached to the rear of the Audio module, at the MCU's rear panel. It is used to playback music or recorded messages from an external device such as a tape or CD player. The music is played when the conference is placed on hold or while waiting in the Participants Queue for the Operator's assistance. This card is optional in the MGC-50/MGC-100 and is embedded in the MGC-25.

Audio File Conversion

The MGC Manager is shipped with a set of default audio (*.wav and *.acc) message files in English and Spanish. These files can be used with the default IVR and Entry Queue Message Services installed with the MCU software, or to create new services. Conversion of audio files to the format that is recognized by the Polycom MCU is necessary when you record custom sets of voice prompts and messages. The audio files must be converted into the MGC internal format (*.aca) before they are downloaded to the MCU unit for use in IVR Message Services. Therefore, you should prepare the audio files before defining the IVR software module properties and IVR and Entry Queue Message Services.



The Audio conversion tool is described in the MGC Manager Administrator's Guide, Chapter 8.

Defining IVR Software Module Properties

The audio messages and prompts played to participants can be recorded in different languages. You can create IVR Message Services and Entry Queue Services for different languages and assign them to different conferences, allowing participants who connect to a conference to hear the messages in the preferred language. Language settings are defined per service and therefore are the same for a given conference; that is, all the participants in the same conference or in the same Entry Queue will hear audio messages and prompts in the selected language.

The IVR Properties enable you to define the languages that will be used in any of the IVR Message Services or Entry Queue Services. Several IVR Messages can use the same language, but only one language may be selected for an IVR Message Service or an Entry Queue Service.

The *IVR Properties* function also enables you to select the audio file to be used for each message type in each language, and to download the messages to the MCU memory.

The *IVR Properties* are defined for both IVR Services and Entry Queue Services.

To define the IVR Properties:

1. Expand the *MCU Configuration* tree.
2. Right-click the *IVR Msg Services* icon and click **Properties**.

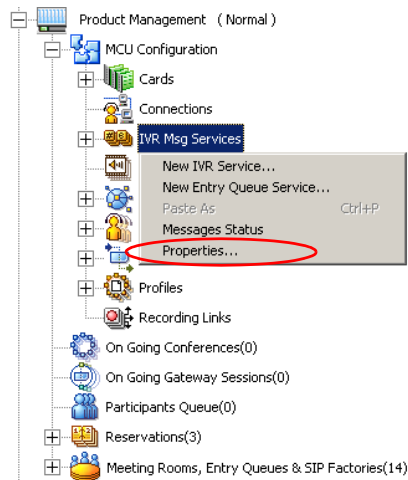

The *IVR Properties* dialog box lists the currently defined languages.

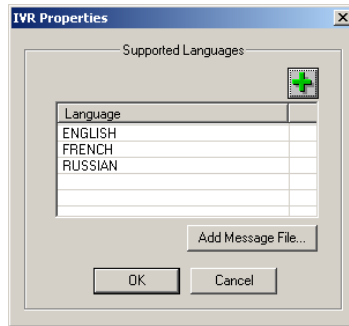

3. To add a new language, click the plus  button. The *Custom Language* dialog box opens.



In the *New Language* field, enter the name of the language to include in the *Supported Languages* list.



The language name cannot include a period (.)

4. Click **OK**.
The new language is added to the *IVR Properties* dialog box.

To download Audio Message files:

(Optional) You can download the Audio Message files during the definition of the IVR Message Service or Entry Queue Service. In that case, you may skip the following steps.

5. In the *IVR Properties* dialog box, click the **Add Message File** button.

The *Add Message File* dialog box opens.

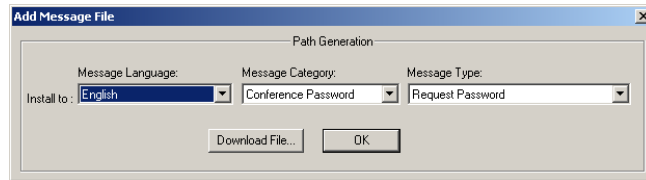

The audio files are downloaded to the MGC unit one at a time, according to the selected category and type. The following steps describe selecting a single *Message Type* (in one of the *Message Categories*) for which the audio file will be downloaded.



You can download several audio files for each Message Type. Each file must be downloaded separately, when the appropriate message *Language*, *Category* and *Type* are selected.

6. In the *Message Language - Install to* list, select the language for which the audio file will be downloaded to the MCU. The languages list includes the languages that were defined in the *IVR Properties*.
7. In the *Message Category* list, select the category for which the audio file will be downloaded and then select the message type to be played.

Table 6-2 lists the available Message Categories and Message Types for each category:

Table 6-2: *IVR Properties - Message Types by Message Category*

Message Category	Message Type	Description
<i>Welcome Message</i>	General Welcome Message	The first message played when the participant connects to the Entry Queue or conference.
	Conference Welcome Message	Played when the participant enters the conference.

Table 6-2: IVR Properties - Message Types by Message Category

Message Category	Message Type	Description
<i>Conference Password</i>	Request Password	Requests the participant to enter the password required to connect to the conference.
	Retry Password	Requests the participant to enter the password again when an incorrect password is entered.
	Request Digit	Requests the participant to enter a digit to connect to the conference. This message is played to dial-out participants when requested to enter a digit to confirm connection.
<i>Conference Chairperson</i>	Chairperson Identifier Request	Requests the participant to enter the chairperson identifier key required to identify them as the conference chairperson.
	Request Chairperson Password	When the participant has been identified as the conference chairperson, requests the participant to enter the chairperson password.
	Chairperson Password Failure Message	When the participant enters an incorrect chairperson password, requests the participant to type it again.
<i>General Operator Assistance</i>	Download files that are played during an On Going Conference when performing various operations, such as when locking or unlocking the conference. These operation are defined in the <i>IVR Service - General</i> dialog box.	
<i>Operator Assistance</i>	Operator Assistance Indication Message	The message is played when the participant is waiting for the operator's assistance.

Table 6-2: IVR Properties - Message Types by Message Category

Message Category	Message Type	Description
<i>Operator Assistance (cont.)</i>	Disconnection Message	Informs that the participant is being disconnected from the conference.
<i>Roll Call SilenceIT</i>	Download the various Audio files that are played when the Roll Call option is enabled for a conference.	
	SilenceIT Menu	Played to announce the SilenceIT feature options.
	Return to Conference Muted	A message indicating which DTMF code the participant must enter to return to the conference muted.
	Un-mute Reminder	A message indicating which DTMF code the participant must enter to unmute his/her line after returning to the conference muted.
	Unmute and Return to Conference	A message indicating which DTMF code the participant must enter to return to the conference unmuted.
	Adjust SilenceIT Sensitivity and Unmute	A message indicating which DTMF code the participant must enter to adjust the sensitivity of the SilenceIT algorithm and return to the conference unmuted.
	Disable SilenceIT and Unmute	A message indicating which DTMF code the participant must enter to disable the SilenceIT option and return to the conference unmuted.

Table 6-2: IVR Properties - Message Types by Message Category

Message Category	Message Type	Description
<i>Silence/IT (cont.)</i>	Participant Detected as Noisy	Informs all participants that the line of a specified participant has been detected as noisy and has been muted.
<i>Conference Id</i>	Download the files requiring the participant/chairperson to enter the required Conference ID to connect to the conference.	

- If required, click **Download File** to download the appropriate audio file to the Polycom MCU memory.
The *Install File* dialog box opens.

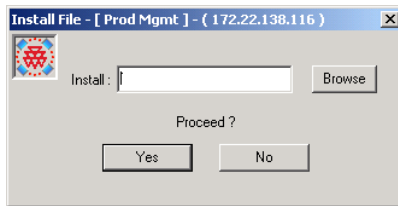

- Click the **Browse** button to select the audio file (*.aca) to download.
The *Select Source File* dialog box opens.

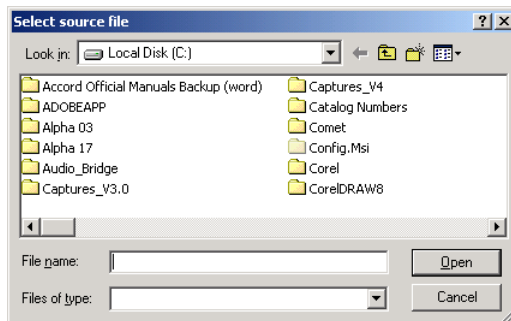

10. Select the appropriate audio file of type *.aca using the standard Windows conventions, and then click the **Open** button.
The name of the selected file appears in the *Install* field in the *Install File* dialog box.
11. In the *Install File* dialog box, click **Yes** to download the file to the MCU memory.
The system returns to the *Add Message File* dialog box.
12. Repeat steps 9 to 11 for each additional audio message to be downloaded to the MCU. Repeat steps 3 to 8 for each additional language to be added to the MCU.
13. Once all the audio files are downloaded to the MCU, close the *Add Message File* dialog box and return to the *IVR Properties* dialog box.
14. In the *IVR Properties* dialog box, click **OK**.

Setting IVR Message Services

The MGC system is shipped with default IVR Service and audio files. An IVR Message Service contains the audio message set for the menu-driven scripts and music input from an external device (background music). You can create a new IVR Message Service when you want to customize audio messages, or when you want to modify the IVR system behavior. For example, a special IVR Message Service can be set for each supported language or for different conference behaviors. Different messages can be created for weekdays and holidays, or special announcements. You can define up to 30 IVR Services for a single MCU.

Defining a New IVR Message Service



Before you define a new IVR Message Service, ensure that the required audio and video files are prepared and converted into .aca format files; otherwise you will not be able to list or select them during the definition process.

To define a new IVR Message Service:

1. Expand the *MCU Configuration* tree.
2. Right-click the *IVR Msg Services* icon and then click **New IVR Service**.

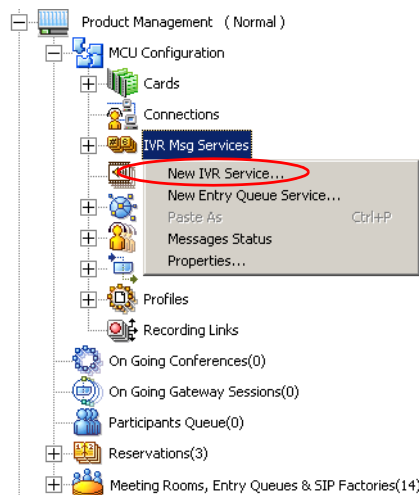

The *IVR - Global* dialog box opens, enabling you to define the general parameters of the IVR Service.

The screenshot shows a dialog box titled "Global" with the following fields and values:

- IVR Service Name: Demo IVR
- Language for IVR: ENGLISH
- External Server Authentication: Never
- Number of User Input Retries: 3
- Timeout for User Input: 5 sec.
- DTMF Delimiter: #

At the bottom of the dialog box, there are four buttons: "< Back", "Next >", "Cancel", and "Help".

3. Define the following parameters:

Table 6-3: IVR Service Properties - Global

Field/Option	Description
<i>IVR Service Name</i>	Enter the name of the IVR Message Service.
<i>Language for IVR</i>	Select the language in which the audio messages and prompts will be heard. The languages are defined in the <i>IVR Properties</i> dialog box. For more details, see page 6-9.

Table 6-3: IVR Service Properties - Global (Continued)

Field/Option	Description
<i>External Server Authentication</i>	<p>You can configure the IVR Service to use an external database application such as <i>WebOffice</i> or <i>WebCommander</i> to verify participants' permission to join the conference. Select one of the following options to determine if the system should request authentication of an external server:</p> <ul style="list-style-type: none"> • Never – to disable this option. The participant's right to join the conference will not be verified with the external database application. • Upon Request – to verify the chairperson password with an external database application only when the participant enters the chairperson identifier key (pound or star). All other participants are connected to the conference as standard, undefined participants. • Always – Any participant's request to join the conference will be validated using the external database application.
<i>Number of User Input Retries</i>	<p>Enter the number of times the participant will be able to respond to each menu prompt before being disconnected from the IVR system or being moved to queue for the operator's assistance. The default value is 3. You can define up to 5 retries.</p>
<i>Timeout for User Input</i>	<p>Enter the time in seconds that the system waits for input from the participant. If that time elapses without participant input, the system registers an input error.</p>
<i>DTMF Delimiter</i>	<p>Enter the key that will be used to indicate a DTMF command sent by the participant or the conference chairperson. Possible keys are the pound key (#) or star (*).</p>

4. Click **Next**.
The *Welcome Message* dialog box opens.

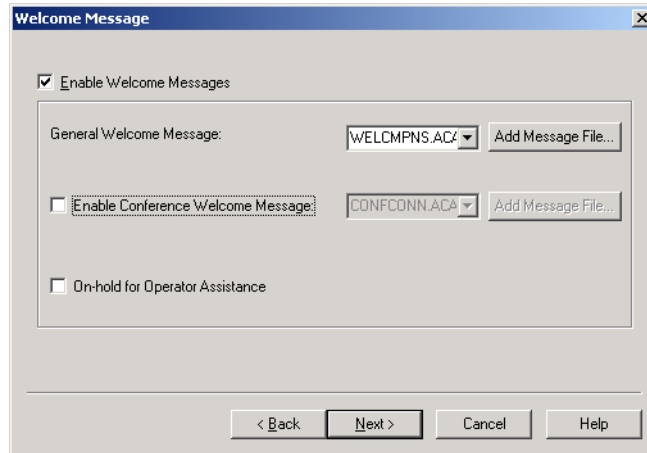

5. Select **Enable Welcome Messages** to enable a welcome message when the participant connects to the conference.
You can select to play a *General Welcome Message*, a *Conference Welcome Message* or to remain *On-Hold for Operator Assistance*. If the *Enable Welcome Messages* option is disabled, the Welcome message is skipped and the participant will hear the next prompt in the IVR menu.



- When the IVR Service is used in conjunction with an Entry Queue Service and the conference is set to Entry Queue Access (forcing participants to go through both queues when connecting to the conference), the participant hears the Welcome message twice (once in the Entry Queue and again in the IVR queue). To avoid hearing the welcome message twice, create an empty welcome message that is two seconds long for the IVR Service. When the participant enters the conference, two seconds of silence will play before the Entry Queue's welcome message.
- If no file was downloaded for a Message type, click **Add Message File** to download the appropriate audio file to the MGC unit's memory. For more details, see page 6-9, Defining IVR Software Module Properties, steps 5-8.

If you have enabled the *Welcome Message* option, select the following options and files:

Table 6-4: IVR Service Properties - Welcome Message

Field/Option	Description
<i>General Welcome Message</i>	<ul style="list-style-type: none"> • None – to skip the General Welcome message (for example, if the participant already heard the message in the Entry Queue). • Select the Message – to be played when the participant first connects to the conferencing service and enters the conference IVR queue. The list includes all the audio files that were downloaded to the MGC unit's memory for this Message type. The file can also be downloaded now.
<i>Conference Welcome Message</i>	<p>Select this option to enable a conference-specific message. When cleared, no message is played when the participant enters the conference.</p> <p>If you have enabled the conference-specific message, select the message the participant will hear when connecting to the conference. The list includes all the audio files that were downloaded to the MGC unit's memory for this Message type. The file can also be downloaded now.</p>
<i>On Hold for Operator Assistance</i>	<p>Select this option, to automatically place participants on hold when connecting to the conference, and wait for the operator to move them to the destination conference. While on hold, participants hear background music (if this feature is enabled). Selecting this option results in the <i>Attended conferencing</i>. For a detailed description, see Chapter 7, "Attended Conferencing".</p>

6. In the *Welcome Message* dialog box, click **Next**. The *Conference Chairperson* dialog box opens.

7. Click **Enable Conference Chairperson** to enable a participant to connect to the conference as a Chairperson and play the appropriate messages while the participant waits in the IVR queue. If this option is disabled, the participant will not hear the prompt to enter the chairperson password and therefore will not be able to connect as chairperson.
8. Select the appropriate audio files and options:

Table 6-5: IVR Service Properties - Conference Chairperson

Field/Option	Description
<i>Chairperson Identifier Request</i>	Select the message requesting the participants to enter the key that identifies them as the conference chairperson.
<i>Request Chairperson Password</i>	Select the message that prompts the participant for the chairperson password.
<i>Chairperson Password Failure Message</i>	Select the message requesting the participant to type that password again when the participant failed to enter the chairperson password correctly.
<i>Chairperson Identifier Key</i>	Enter the key to be used for identifying the participant as a chairperson. Possible keys are: pound key (#) or star (*).

Table 6-5: IVR Service Properties - Conference Chairperson (Continued)

Field/Option	Description
<i>Use Chairperson Password as Conference Password</i>	Select this option to enable the caller to join to the conference as the chairperson, using only the chairperson password instead of two passwords: the Conference Entry Password and the Chairperson Password. Note: When this option is enabled, the chairperson password must be different from the conference entry password. You can change the status of any participant to Chairperson during an On Going Conference by using the appropriate DTMF code and password.
<i>Billing Code</i>	Select this option to enable the chairperson to enter a code for billing purposes.



If no file was downloaded for a Message Type, click **Add Message File** to download the audio file to the MGC unit's memory. For more details, see Defining IVR Software Module Properties, page 6-10, steps 5-8.

9. Click **Next**.

The *Conference Password* dialog box opens.

10. Select the **Enable Password Message** check box to request the conference password before moving the participant from the IVR queue to the conference.

You can configure the IVR system to behave differently when handling dial-in and dial-out participants.

Dial-in participants can be requested to enter the conference password as a security measure to ensure that only authorized participants connect to the conference.

When the system connects dial-out participants to the conference, in many cases there is no need for the password (dial-out participants are predefined in the system), but they may need to press a key to confirm presence, to be able to join the conference.

IVR Message Services may be configured for password request according to the required system behavior. There are three types of password options for dial-in and dial-out participants.

11. Select the required system behavior as follows:
- **Request password** - The system requests the participant to enter the conference password, and after the correct conference password is provided, moves the participant to the conference.
 - **Request digit /identifier** - The system requests the participant to press a random key, and after any key is pressed, moves the participant to the conference. This option prevents an answering machine or voice mail from entering the conference.
 - **None** - The participant is moved to the conference without being asked to enter a password or press a key.
12. If you have enabled the conference password request and you have defined the system behavior for dial-in and dial-out participants, select the various audio messages that will be played in each case. The following audio file messages are available:

Table 6-6: IVR Service Properties - Conference Password

Field/Option	Description
<i>Request Password</i>	Select the message that prompts the participant for the conference password.

Table 6-6: IVR Service Properties - Conference Password

Field/Option	Description
<i>Retry Password</i>	Select the message that requests the participant to enter the conference password again when failing to enter the correct password.
<i>Request Digit</i>	Select the message that prompts the participant to press any key.



If no file was downloaded for a Message Type, click **Add Message File** to download the audio file to the MGC unit's memory. To see the procedure, see Defining IVR Software Module Properties, page 6-10, steps 5-8.

13. Click **Next**.

The *General* dialog box opens.

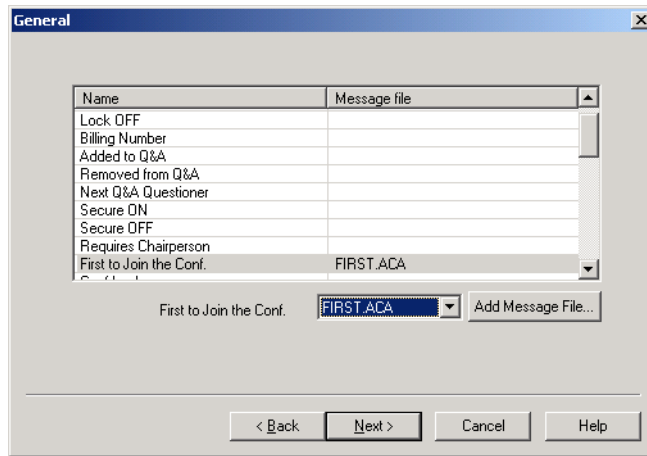

This dialog box lists additional audio messages and prompts that may be played while joining the conference or during the On Going Conference.

14. In the *Name* column, select the required message type and then select the message (audio) file to be played when the operation is performed or when the selected event occurs.

Table 6-7: IVR Service Properties - General Messages

Message Type	Message Description
<i>Lock ON</i>	Indicates that the conference is now locked to dial-in participants. This message is played to all the conference participants.
<i>Lock OFF</i>	Indicates that the conference is now unlocked to dial-in participants. This message is played to all the conference participants.
<i>Billing Number</i>	Requests the participant to enter a code for billing purposes.
<i>Added to Q&A</i>	Confirms that the participant was added to the Q&A queue and has to wait for their turn to speak.
<i>Removed from Q&A</i>	Played to the participant that was removed from the Q&A queue.
<i>Next Q&A Questioner</i>	Indicates to the participant who is next in the Q&A queue to prepare to ask a question.
<i>Secure ON</i>	Played to the conference when the chairperson secured the conference so it cannot be entered by additional participants or by operator. In this mode, the operator cannot monitor the participants and can only terminate the conference. Note: Conferences are secured and unsecured by the chairperson via DTMF commands.
<i>Secure OFF</i>	Played to the conference when the chairperson cancelled the secured mode and the conference returned to its normal state.
<i>Requires Chairperson</i>	Played to inform participants that the conference will not start until the chairperson joins the conference. Note: This message is played only when the “ <i>Start Confy. Requires Chairperson</i> ” option is selected in the <i>Conference Properties - Settings</i> dialog box.
<i>First to Join the Conf.</i>	Played to the participant who is first to join the conference, to clarify the silence.
<i>Conference Locked</i>	Played to dial-in participants when they try to connect to a locked conference.

Table 6-7: IVR Service Properties - General Messages (Continued)

Message Type	Message Description
<i>Mute All ON</i>	Played to the conference to inform all participants that they are all muted, except the conference speaker.
<i>Mute All OFF</i>	Played to the conference to inform all participants that they are unmuted and that the <i>Mute All Except Me</i> mode was cancelled.
<i>Chairperson Exit</i>	Played to the conference when the chairperson exits the conference and the conference is automatically terminated. Note: This message is played only when the <i>Terminate After Chairperson exits</i> option is selected in the <i>Conference Properties - Settings</i> dialog box.
<i>End Time Alert</i>	Played to warn participants that the conference is about to end and cannot be extended.
<i>Change Passwords Menu</i>	Voice menu played when the participant requests to change the conference or chairperson password, detailing the steps required to complete this operation
<i>Change Conf Password</i>	This prompt requests the participant to enter a new conference password when the participant is attempting to modify the conference password.
<i>Change Chairperson Password</i>	This prompt requests the participant to enter a new chairperson password when the participant is attempting to modify the chairperson password.
<i>Confirm Password Change</i>	Requests the participant re-enter the new password.
<i>Change Password Failure</i>	A message played when the participant entered an invalid password, usually when the password is already in use by another conference or chairperson.
<i>Self Mute</i>	A confirmation message that is played when the participants request to mute their own line.
<i>Self UnMute</i>	A confirmation message that is played when the participants request to unmute their own line.

Table 6-7: IVR Service Properties - General Messages (Continued)

Message Type	Message Description
<i>Chairperson Help Menu 1</i>	<p>A help menu which is played on chairperson's request. Lists operations that can be performed by the chairperson (and their respective DTMF codes) to participants requesting it. The playback can be stopped anytime.</p> <p>The length of a voice message that can be recorded for a Help file is limited to 30 seconds. To overcome this limitation, two audio files can be played one after another as a single menu. Grouping of two audio files into one help menu can be done for the chairperson help menu as well as for the participant help menu. If you configure two help menu messages, they will be heard in sequence as one menu.</p> <p><i>Chairperson Help Menu 1</i> is the first file that will be played.</p> <p>The help menus are usually recorded by the conferencing service provider as voice messages and are configured as any other voice message in the system.</p> <p>Note: If you intend to modify the default DTMF codes, the default voice message files for the help menus that are shipped with the system will have to be replaced with new recordings that list the new DTMF codes.</p>
<i>Chairperson Help Menu 2</i>	<p>The audio file containing additional DTMF codes that can be used by the chairperson when two help menu messages are recorded for the chairperson operation. This file will be played after the file assigned to the <i>Chairperson Help Menu 1</i>.</p>
<i>Participant Menu 1</i>	<p>The audio file listing DTMF codes that can be used by the participant. The length of a voice message that can be recorded for a Help file is limited to 30 seconds. To overcome this limitation, two audio files can be played one after another as a single menu.</p> <p><i>Participant Menu 1</i> is the first file that will be played.</p>

Table 6-7: IVR Service Properties - General Messages (Continued)

Message Type	Message Description
<i>Participant Menu 2</i>	The audio file listing additional DTMF codes that can be used by the ordinary participant when two help menu messages are recorded for the participant operation. This file will be played after the file that was assigned to the <i>Participant Menu 1</i> .
<i>Invite Help Menu</i>	The audio file listing DTMF codes available to the participant or the chairperson during the <i>Invite</i> session.
<i>Voting Help Menu</i>	The audio file listing DTMF codes available to the participant or the chairperson who controls the voting session, depending on the configuration in the DTMF codes dialog box.
<i>Maximum Participants Exceeded</i>	A message indicating that the participant cannot join the destination conference as the maximum allowed number of participants will be exceeded.
<i>Recording in Progress</i>	A Message indicating that the ReadRecorder recording has started.
<i>Recording Failed</i>	A Message indicating that the ReadRecorder recording has failed to record the conference.

15. To assign the audio file (if one was downloaded) to the message type, click the appropriate table entry.
 The *Message Type* appears at the bottom of the table and the drop-down list of message files is enabled.
 If the appropriate message was not downloaded, you can download it now by clicking **Add Message File**. For more information, see *Defining IVR Software Module Properties*, page 6-9, steps 5-8.
16. Click **Next**.

The *Operator Assistance* dialog box opens.

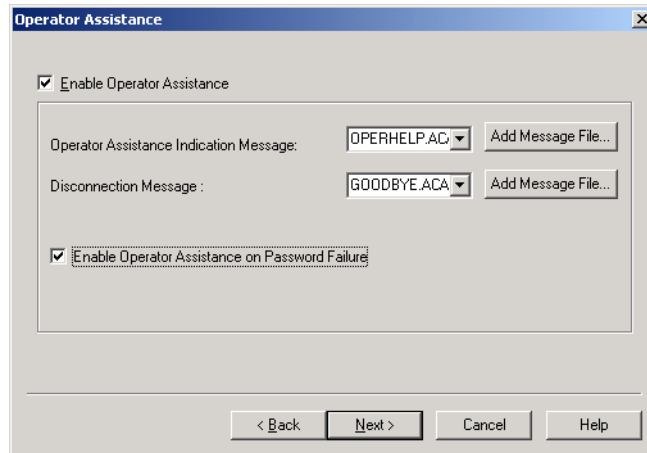

17. Select **Enable Operator Assistance** to allow the operator to assist participants waiting in the IVR queue, or during the On Going Conference when requesting help.
18. When this option is enabled, select various audio messages to be played when the participant fails to enter the correct conference password. .

Table 6-8: IVR Service Properties - Operator Assistance

Field/Option	Description
<i>Operator Assistance Indication Message</i>	<p>If the Operator Assistance option is enabled, select the appropriate audio file to be played to the participant in the following instances:</p> <ul style="list-style-type: none"> • The participant requested help • The participant failed to enter the correct conference entry password and the “Enable Operator assistance on Password Failure” option is selected in this dialog box • The “On Hold for Operator Assistance option is selected in the <i>IVR - Welcome Message</i> dialog box.
<i>Disconnection Message</i>	<p>If the Operator Assistance option is disabled, select the appropriate audio file to be played when the participant fails to enter the correct conference password and is disconnected from the conference.</p>

Table 6-8: IVR Service Properties - Operator Assistance (Continued)

Field/Option	Description
<i>Enable Operator Assistance on Password Failure</i>	Select this check box to allow the operator to assist the participant once the participant has failed to enter the correct conference password in all the allowed attempts. When this check box is cleared, the participant will be disconnected from the conference when failing to enter the correct conference password after hearing the disconnection message.



If no file was downloaded for a Message Type, click **Add Message File** to download the appropriate audio file to the MGC unit's memory, see page 6-9, Defining IVR Software Module Properties, steps 5-8.

19. Click **Next**.
The *Roll Call* dialog box opens.

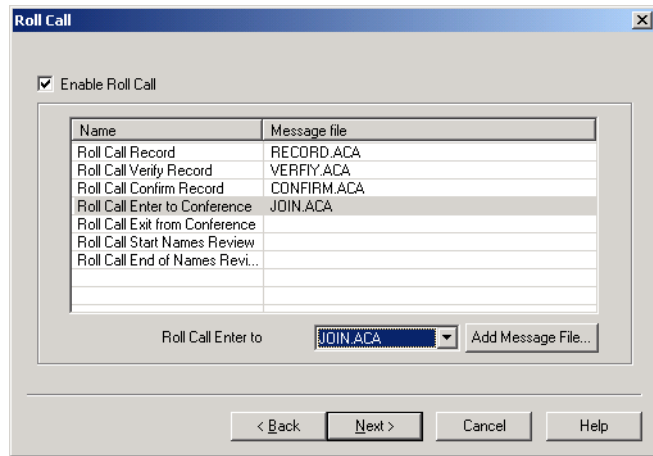

The Roll Call feature of the IVR Message Service is used to record the participants' names for playback when the participants join and leave a conference or when the chairperson requests the Roll Call. Participants connecting to the conference are asked to record their name.

20. To enable this option, select **Enable Roll Call**.
21. To assign the audio file to the message type, click the appropriate entry. The Message Type appears at the bottom of the table and the drop-down list displays the names of the audio files stored in the MGC memory.



If the *Roll Call* option is enabled, all its Message Types must be assigned the appropriate audio files.

22. From the drop-down list, select the appropriate audio file.

Table 6-9: IVR Service Properties - Roll Call Messages

Roll Call Message	Description
<i>Roll Call Record</i>	Requests the participant to state the name for recording when the participant connects to the conference. Note: The recording is automatically terminated after two seconds.
<i>Roll Call Verify Record</i>	Verification message added to the playback of the recorded name: "The name you have recorded is ..."
<i>Roll Call Confirm Record</i>	Prompts the participant to confirm the recorded name or to record the name again. Note: This message is optional and is not played to the participant when the appropriate flag in the "system.cfg" is set to NO.
<i>Roll Call Enter to Conference</i>	A voice message added to the playback of the recorded name stating that the participant has joined the conference: "has joined the conference".
<i>Roll Call Exit from Conference</i>	A voice message added to the playback of the recorded name stating that the participant has left the conference: "...has left the conference".

Table 6-9: IVR Service Properties - Roll Call Messages (Continued)

Roll Call Message	Description
<i>Roll Call Start Names Review</i>	Played when Roll Call is requested by the chairperson, introducing the names of the conference participants in the order they joined the conference.
<i>Roll Call End Names Review</i>	Played at the end of Roll Call, to indicate that the listing of participant names is concluded.

23. Click **Next**.
The *SilenceIT* dialog box opens.

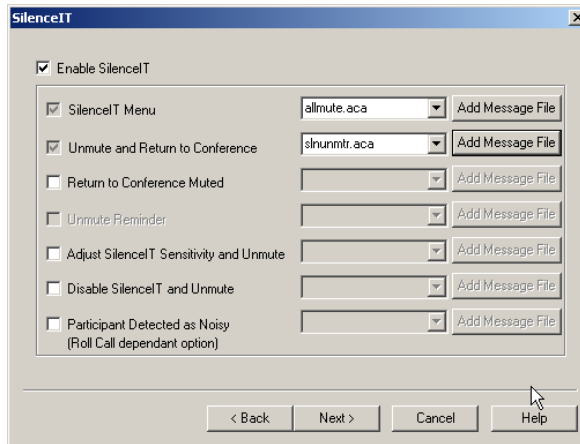

SilenceIT is used to automatically mute participant lines that were detected as noisy.

24. Select **Enable SilenceIT** to enable this feature.

25. Select the SilenceIT options and voice messages.
The following table summarizes the SilenceIT options:

Table 6-10: IVR Service Properties - SilenceIT Messages

SilenceIT Message	Description
<i>SilenceIT Menu</i>	Select the message played when a participant is automatically muted by the MCU. It notifies participants that the line has been muted and indicates which DTMF code they should enter to listen to the available options. The default voice message is: "Your line has been muted due to a noisy line. For list of available options, press 9." Note: This message is mandatory.
<i>Unmute and Return to Conference</i>	Select the message that indicates which DTMF code participants should enter to return to the conference unmuted. The default voice message is: "Press 1 to unmute and return to the conference." Note: This message is mandatory.
<i>Return to the Conference Muted</i>	(Optional) Select this check box to enable the option to return to the conference muted. Then select the message indicating the DTMF code to use. The default voice message is: "Press 2 to return to the conference muted."
<i>Unmute Reminder</i>	Select the message that indicates which DTMF code to enter to unmute the participant's line once they return to the conference muted. This message is played once, as a reminder when the participant has selected to return to the conference muted. The default voice message is: "Press #, 6 at any time to unmute your line." Note: This message is enabled when the <i>Return to the Conference Muted</i> check box is selected.

Table 6-10: IVR Service Properties - SilenceIT Messages (Continued)

SilenceIT Message	Description
<i>Adjust SilenceIT Sensitivity and Unmute</i>	Select this check box to enable the option to adjust (reduce) the SilenceIT sensitivity and to return to the conference unmuted. The noise detection sensitivity remains at the adjusted level until the end of the conference. Then select the message that indicates the DTMF code to use. The default voice message is: "Press 3 to reduce the noise detection level and return to the conference."
<i>Disable SilenceIT and Unmute</i>	Select this check box to enable the option to disable the SilenceIT algorithm and return to the conference unmuted. Then select the message indicating the DTMF code to use. The default voice message is: "Press 4 to disable noise detection and return to the conference."
<i>Participant's Line Detected as Noisy</i>	Select this check box to enable the system to inform all participants that the line of participant X has been detected as noisy and has been muted, and then select the appropriate message. The default voice message is: "...(participant's name) has been automatically muted due to a noisy line." Note: This option is available only if the Roll Call option on the <i>Roll Call</i> tab is enabled in the same IVR Message Service.



If no file was downloaded for a Message Type, click **Add Message File** to download the appropriate audio file to the MGC unit's memory, see "Defining IVR Software Module Properties" on page 6-9, steps 5-8.

26. Click **Next**.

The *DTMF Codes* dialog box opens. This dialog box lists the default DTMF codes for the various functions that can be performed during the audio conference by all participants or by the chairperson. A combination of digits activates a function, for example, ***70** activates the *Lock Conference* feature. For each function, you can modify the DTMF code and the permission.

For the list of all actions and their respective default DTMF codes, see “Managing Conferences Using DTMF Codes” on page 4-62.

To print the DTMF codes data, see “Printing IVR/DTMF Codes” on page 6-51.

27. Optional. In the *Name* field, click the function whose code you wish to modify.

The appropriate DTMF code appears in the box below the list.

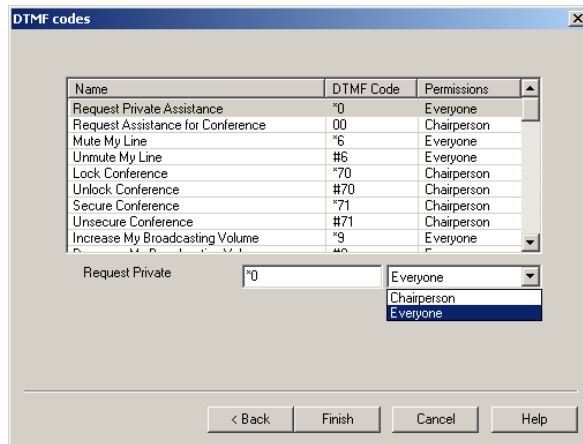

28. In the *DTMF Code* (left) field, enter the new code.
In the *Permission* (right) field, select whether this function may be used by all conference participants or only the chairperson.
29. Click **Finish** to complete the IVR Service definition.
The new IVR Message Service is added to the *IVR Services* list.

Listing IVR Message Services

You can list the currently defined IVR Services in the *Browser* pane of the MGC Manager main window.

To list the IVR Message Services:

1. Expand the *MCU* tree and then expand the *MCU Configuration* tree to view its options.
2. Expand the *IVR Msg Services* tree, to list the IVR Message Services. The list of currently defined IVR Message Services and Entry Queue Services is displayed.

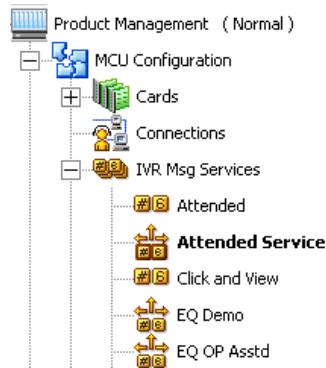

To view or modify the properties of a specific IVR Message Service, double-click the icon of the service in the list.

Setting an IVR Message Service as Default

The first IVR Service that was defined in the system, is automatically set as the default IVR Service. However, if several services are defined for the MCU, you can choose another service as the default IVR Service. This default IVR Service will be used in conferences where the IVR Service function is enabled but no specific IVR Service was selected.

To select the default IVR Service:

1. List the IVR Services defined in the system. For details, see “Listing IVR Message Services” on page 6-36.
2. Right-click the icon of the IVR Message Service to set as default, and then click **Set As Default**.

The selected IVR Message Service appears in bold (both name and icon) indicating that it is the current default service.

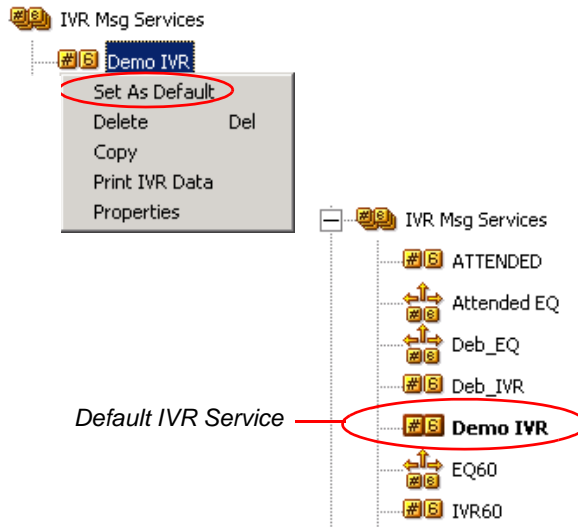

Modifying IVR Message Service Properties

You can change one or several properties of a defined IVR Service, at the setup stage.

To modify the properties of an IVR Service:

1. List the IVR Services defined in the system. For details, see “Listing IVR Message Services” on page 6-36.
2. Right-click the icon of the IVR Message Service to modify, and then click **Properties**. Alternatively, double-click the icon.

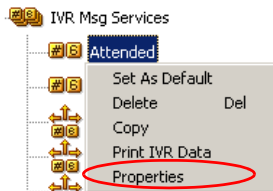

The *IVR Message Service* properties dialog box opens. The tabs and options of this dialog box are described in “Defining a New IVR Message Service” on page 6-16.

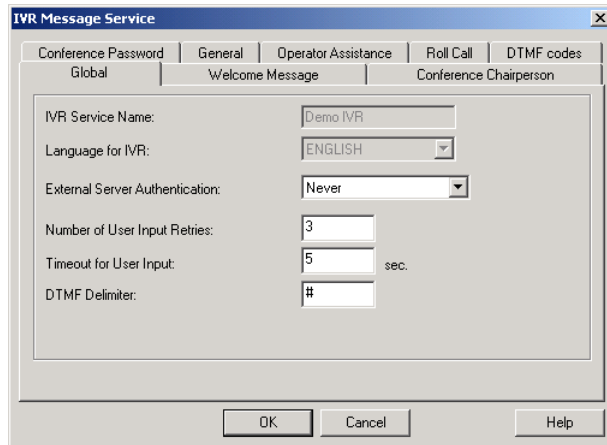

3. Modify the required parameters or download the required audio file.
4. Click **OK** to apply the settings.

Assigning IVR Services to Conferences

IVR Message Services enable the conference participants and the chairperson to perform various operations from their endpoints using DTMF codes, and and to utilize the SilenceIT and Roll Call features. Assigning a defined IVR Service and all its options to a conference is done during the definition of a new On Going Conference or Reservation.



The selected IVR Service and its features and options cannot be modified or disabled during the On Going Conference.

To assign an IVR Service to an Audio Only conference:

When defining a new Audio Only conference in the *Setting* tab:

1. In the *General Settings* pane, click the **Enable IVR Service** check box.
2. From the *Message Service Name* list, select the name of the IVR Service or leave this field blank if you wish to use a default IVR Service. The selected IVR Service (all its properties including Roll Call and SilenceIT, if those are enabled) will be applied to this On Going Conference or Reservation.

The screenshot shows the 'conf genl meet Properties (Product Management)' dialog box with the 'General Settings' tab selected. The 'Enable IVR Service' checkbox is checked, and the 'Msg Service Name' dropdown is set to 'IVR70'. Other settings include 'VTX:1000', 'On Hold', 'Enable Invite', 'SilenceIT', 'Conference Lock', 'Mute Meet Me parties', 'Start Conf. Requires Chairperson', 'Terminate After Chairperson Exits', 'Auto Termination', 'Before First Join: 5 Min', 'After Last Quit: 1 Min', 'Media Settings', 'Audio Alg: 56 (G711)', 'Roll Call', 'Entry Tone / Roll Call announcement', 'End Time Alert Tone: 5', 'Exit Tone / Roll Call announcement', and 'Audio Mix Depth: 3 Sites'.

Defining a New Entry Queue Message Service

An Entry Queue Message Service is a subset of an IVR Message Service that is used with Entry Queues. It includes a set of voice prompts that are used to guide the caller to the appropriate conference. You can create different Entry Queue Services for different languages and personalized voice messages.

To set the new Entry Queue Message Service:

1. Expand the *MCU* tree, and then expand the *MCU Configuration* tree.
2. Right-click the *IVR Services* icon, and then click **New Entry Queue Service**.



The *Entry Queue Message Service* dialog box opens.

This dialog box enables you to define the general parameters of the Entry Queue Service.

3. Define the following parameters:

Table 6-11: Entry Queue Service - Global Parameters

Option	Description
<i>Entry Queue Service Name</i>	Type the name of the <i>Entry Queue</i> Message Service.
<i>Language for IVR</i>	Select the language in which the Audio Messages and prompts will be heard. The Languages are defined in the <i>IVR Properties</i> dialog box.
<i>External Server</i>	Select Conference NID to verify the conference Numeric ID with an external database application. Select None to disable the external database validation process.
<i>Number of User Input Retries</i>	Enter the number of times the user is able to respond to each menu prompt before the participant is disconnected from the IVR system or waits for the Operator's assistance.
<i>Timeout for User Input</i>	Enter the duration in seconds that the system waits for input from the participant before it is considered as an input error.

Table 6-11: Entry Queue Service - Global Parameters (Continued)

Option	Description
<i>DTMF Delimiter</i>	The interaction between the caller and the system is done via touch-tone signals (DTMF codes). Enter the key that will be used to indicate a DTMF command sent by the participant or the conference chairperson. Possible keys are the pound key (#) or star (*).

4. Click **Next**.
The *Welcome Message* dialog box opens. This dialog box contains a limited set of options that are identical to those defined in the *IVR - Welcome Message* dialog box.

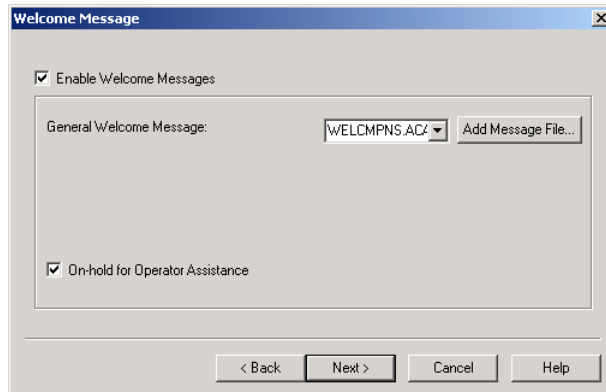

If the Entry Queue Service is used in conjunction with an IVR Service and the conference is set to Entry Queue Access, forcing participants to go through both queues when connecting to the conference, will require the participant to hear the Welcome message twice (once in the Entry Queue and the second time in the IVR queue). To avoid hearing the welcome message twice, create an empty welcome message that is two seconds long for the IVR Service. When the participant enters the conference, two seconds of silence will play before the Entry Queue's welcome message.

5. Select **Enable Welcome Messages** to enable a welcome message when the participant connects to the conference.
If the *Enable Welcome Messages* option is disabled, the Welcome message is skipped and the participant will hear the next prompt in the Entry Queue menu.

6. Define the following parameters:

Table 6-12: IVR Properties - Welcome Message

Field/Option	Description
<i>General Welcome Message</i>	<ul style="list-style-type: none"> <i>Message</i> – to be played when the participant first connects to the conferencing service and enters the Entry Queue. The list includes all the audio files that were downloaded to the MGC unit's memory for this Message type. <p>Add Message File – If you have not downloaded the audio files prior to the definition of the Entry Queue Service, click the button to download the audio file now.</p>
<i>On Hold for Operator Assistance</i>	<p>When you select this option, participants are automatically placed the on hold when connecting, and wait for the operator to move them to the destination conference. While on hold, participants hear background music (if this feature is enabled).</p> <p>Note: Selecting this option results in the <i>Attended</i> status, where the operator's assistance is necessary to connect participants to conferences.</p>



Adding messages to the Entry Queue Service is similar to adding messages to the IVR Service. For more information about adding new messages to the Entry Queue Service, see Defining IVR Software Module Properties, page 6-10, steps 5-8.

- Click **Next**.
The *Conference ID* dialog box opens.

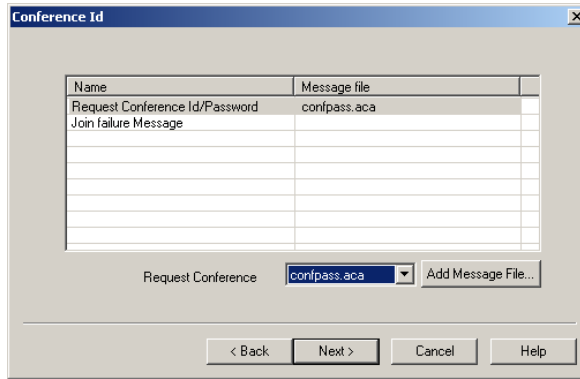

- To assign the audio file to the message type, click the appropriate table entry.

The message type appears at the bottom of the table and the drop-down list displays the names of the audio files stored in the MGC unit's memory.

The following messages and prompts may be played to request the conference Numeric ID/Password:



If the files were not downloaded prior to the definition of the Entry Queue Service, or if you want to add new audio files, click **Add Message File** to download the appropriate audio file to the MGC unit's memory. Adding messages to the Entry Queue Service is similar to adding messages to the IVR Service. For more information about adding new messages to the Entry Queue Service, see page 6-9, Defining IVR Software Module Properties, steps 5-8.

Table 6-13: Entry Queue Properties - Conference ID

Field/Option	Description
<i>Request Conference Id/ Password</i>	Select the audio file that prompts the participant for the conference Numeric ID or the conference password, depending on the MCU configuration. The Numeric ID or password is used to route the participant to the target conference.

Table 6-13: Entry Queue Properties - Conference ID (Continued)

Field/Option	Description
<i>Join Failure Message</i>	Select the audio file that requests the participant to re-enter the conference Numeric ID or password when failing to enter the correct conference Numeric ID or password.

9. Click **Next**.
The *Operator Assistance* dialog box opens.

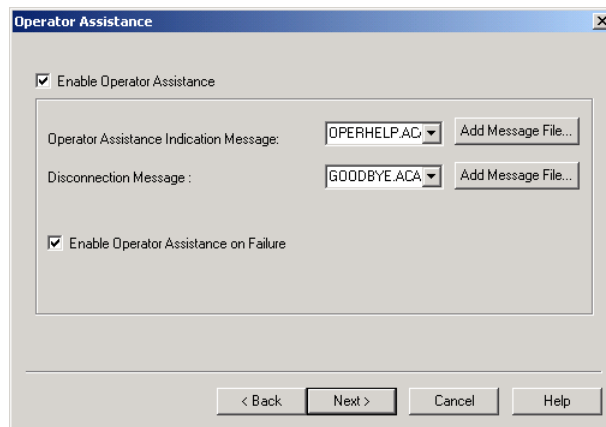

10. Select **Enable Operator Assistance** to enable operator assistance when the participant waits in the IVR queue and during the conference.
11. Select the messages to be played when the participant requests or is waiting for operator's assistance, or when the participant fails to enter the correct conference password:



If the files were not downloaded prior to the definition of the Entry Queue Service, or if you want to add new audio files, click **Add Message File** to download the appropriate audio file to the MGC unit's memory. Adding messages to the Entry Queue Service is similar to adding messages to the IVR Service. For more information about adding new messages to the Entry Queue Service, see page 6-9, Defining IVR Software Module Properties, steps 5-8.

Table 6-14: IVR Properties - Operator Assistance Messages

Field/Option	Description
<i>Operator Assistance Indication Message</i>	Select the audio file to be played to the participant when: <ul style="list-style-type: none"> • The participant requested help. • The participant entered an incorrect conference password. • The On Hold for Operator Assistance option is selected in the IVR - Welcome Message dialog box.
<i>Disconnection Message</i>	If the Enable <i>Operator Assistance on Password Failure</i> option is disabled, select the audio file to be played when the participant enters an incorrect password and is to be disconnected from the conference.

12. Select the **Enable Operator Assistance on Failure** check box to enable operator assistance when the participant fails to correctly access the conference. When this option is cleared, a participant who failed all password attempts will be automatically disconnected from the conference, after hearing the disconnection message.
13. Click **Finish** to complete the Entry Queue Service definition. The new Entry Queue Service is added to the *IVR Message Services* list.

Assigning Entry Queue Services to an Entry Queue

To enable the system to route participants to their conferences according to the conference Numeric ID or password (depending on the MCU configuration), an Entry Queue Service must be assigned to the Entry Queue. Assigning is done during the definition of a new Entry Queue, in the *Entry Queue Properties* dialog box.

To assign the Entry Queue Service to an Audio only conference:

- In the *Entry Queue Properties* dialog box, in the *Entry Queue Message Service* list, select the required Entry Queue Service, or leave this box empty to use the default Entry Queue (if one is defined).

The screenshot shows the 'Entry Queue Properties (Product Management)' dialog box. The 'Entry Queue Settings' section includes a 'Name' field with 'Team1 Queue', a 'Numeric ID' field, and an 'Entry Queue Service' dropdown menu set to 'Attended Service'. The 'Target Conference Settings' section includes an 'Audio Alg' dropdown set to '56 (G711)'. The 'Target Conferences' section has 'Audio Only' checked, 'IP Only' unchecked, and 'Encryption' unchecked. At the bottom, there is a table with columns 'Service Name', 'Dial-in Number (1)', and 'Dial-in Number (2)'. The table is currently empty. There are 'OK' and 'Cancel' buttons at the bottom of the dialog.



You can set either an IVR Service or an Entry Queue Service as the default *IVR Message Service*, but not both. If an IVR Service is selected as default, you must assign an Entry Queue Service here.

Connecting to a Conference from an Entry Queue

When a conference is accessed through an Entry Queue and an IVR Service is assigned to the conference, the connection to the conference is made in two stages. In the first stage, the participants connect to the Entry Queue where they are routed to their destination conference according to the conference Numeric ID or password, depending on the MCU configuration. In the second stage, the participant is prompted for the conference password and the chairperson password. The participant can also be prompted for additional information.

To minimize the number of voice prompts to which the caller has to respond before connecting to the conference, it is recommended to exclude from the IVR Service prompts that are part of the Entry Queue Service, such as the general Welcome message.



To enable the touch-tone commands from the participant's telephone during an On Going Conference, an IVR Service must be assigned to the conference.

Viewing the Audio Messages Status

The number of messages that can be downloaded to the MGC unit's Audio+ card is defined in the "system.cfg" file. The audio files for the messages and voice prompts are sorted and stored in groups according to their duration.

Five duration categories are provided:

2-second, 4-second, 8-second, 16-second and 32-second groups.

The messages are sorted in the Audio+ card of the MCU. The number of messages that can be downloaded to the Audio+ card for each of these groups, is listed in Table 6-15.

Table 6-15: Max. Number of Messages by Duration Category Group

Duration Category Group	Max. Number of Voice Messages in Group
2-second duration	360
4-second duration	438
8-second duration	172
16-second duration	24
32-second duration	36

You can check the number of audio files that are currently stored on the Audio+ card and the status of the downloading process (if you check the status during the download process).

To view the status of the audio messages:

1. Expand the *MCU* tree, and then expand the *MCU Configuration* tree.
2. Right-click the *IVR Services* icon, and then click **Messages Status**.

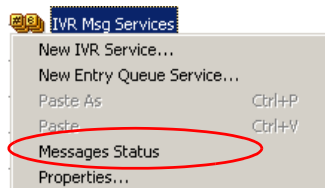

The *IVR Messages Status* dialog box opens, listing the IVR messages audio files that are currently stored on the Audio+ card, sorted according

to their duration.

The list also displays the file's name and its download status.

IVR Messages Status

Download Status: Ok

Message Type	Message Name	Status
32 Sec.	LDRHLP1.ACA	Downloaded
32 Sec.	LDRHLP2.ACA	Downloaded
32 Sec.	PRTCPLP.ACA	Downloaded
32 Sec.	INWITHLP.ACA	Downloaded
32 Sec.	VOTEHLP.ACA	Downloaded
16 Sec.	PINCHANG.ACA	Downloaded
8 Sec.	OPRHLP.ACA	Downloaded
8 Sec.	CONFPASS.ACA	Downloaded
8 Sec.	ENTRYOPT.ACA	Downloaded
8 Sec.	LEDRPASS.ACA	Downloaded
8 Sec.	RERECRD.ACA	Downloaded
8 Sec.	BILLING.ACA	Downloaded
8 Sec.	NEWPIN.ACA	Downloaded
8 Sec.	NEWCHAIR.ACA	Downloaded
8 Sec.	NEWCNFRM.ACA	Downloaded
8 Sec.	NEWCNFRM.ACA	Downloaded
8 Sec.	NEWCNFRM.ACA	Downloaded

Messages Occupancy

Duration Category	Maximum Capacity	Currently Stored Files
2 Sec:	360	8
4 Sec:	438	22
8 Sec:	172	3
16 Sec:	24	1
32 Sec:	36	5

Maximum number of audio messages for each category

Currently stored files

Close

The *Messages Occupancy* pane shows:

- The maximum number of audio messages for each category that can be stored on the Audio+ card, as configured in the “system.cfg” file.
- The number of audio files in each duration category that are currently stored on the Audio+ card.

3. Click **Close** to exit the dialog box.

Printing IVR/DTMF Codes

You can print the list of operations and their corresponding DTMF codes defined in the IVR Message Service. Data may be sent to a printer, saved to a file or copied to a clipboard. The printed list includes the operation, the input keys that are required and the type of permission for this operation (chairperson only or everyone).

To print the list of DTMF codes:

1. Expand the *IVR Message Services* tree.
2. Right-click the icon of the IVR Message Service whose DTMF codes to print, and then click **Print IVR Data**.

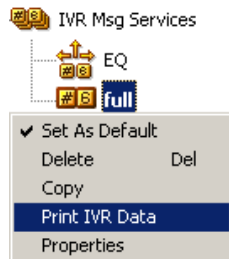

The *Print* dialog box opens.

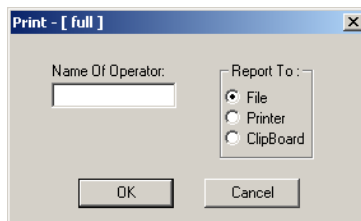

3. In the *Name Of Operator* field, enter the name of the operator who initiated the report (optional).
4. From the *Report To* options, select the destination to which the codes data is to be sent:
 - **File** - To save the list of DTMF codes to a text file
 - **Printer** - To print the list of DTMF codes to the default printer
 - **Clipboard** - To copy the list of DTMF codes to the clipboard for use by other applications

5. Click **OK**.
If you select the *Report To - File* option, a browser dialog box opens.
6. Enter the file name, select the destination directory and then click **Save**.

In the sample text file of DTMF codes, the first column lists the function to be performed (the DTMF name), the second column lists the DTMF string to be used, and the third column lists the required permission.

```

IVR70 IVR.txt - Notepad
File Edit Format View Help
Operator:
-----
IVR Service: IVR70
-----

DTMF Name                                DTMF String    Permission
-----
Request Private Assistance                *0             Everyone
Request Assistance for Conference         00             Chairperson
Mute My Line                              *6             Everyone
Unmute My Line                           *6             Chairperson
Lock Conference                           *70            Chairperson
Unlock Conference                         *70            Chairperson
Secure Conference                         *71            Chairperson
Unsecure Conference                       *71            Chairperson
Increase My Broadcasting volume           *9             Everyone
Decrease My Broadcasting volume           *9             Everyone
Mute All but Me                           *5             Chairperson
Cancel Mute All but Me                    *5             Chairperson
Change Password                           *77            Chairperson
Place Conference On-Hold                   *1             Chairperson
Reinstate On-Hold Conference               *1             Chairperson
Mute Dial-In Participants                  *86            Chairperson
Cancel Mute Dial-In Participants           *86            Chairperson
Start Voting Session                       *81            Chairperson
Stop Voting Session                        *81            Chairperson
New Voting Session                         *82            Chairperson
Cancel Voting Session                      *82            Chairperson
Ask a Question                             *22            Everyone
Cancel My Question                         *22            Everyone
Next in Line Question                      *23            Chairperson
End Current Question                       *23            Chairperson
Cancel All Questions                       *24            Chairperson
Dial-out to Invitee                       *4             Chairperson
Admit Invitee & Continue Dial-out          *1             Chairperson
Disconnect Invitee & Continue Dial-out     *2             Chairperson
Admit Invitee & Return to Conference       *3             Chairperson
Disconnect Invitee & Return to Conference  *4             Chairperson
Play Menu                                  *83            Everyone
Enable Roll Call                           *32            Chairperson
Disable Roll Call                          *32            Chairperson
Roll Call Review Names                     *33            Chairperson
Roll Call Stop Review Names                *33            Chairperson
Start Dial Out                             *25            Chairperson
Conference Termination                     *87            Chairperson
Start Click & View                         **             Everyone
    
```

For a full list of IVR messages and their DTMF codes, see MGC Manager User's Guide Vol. I, Chapter 6, "Using DTMF Codes during a Conference".

Default IVR Prompts and Messages

The system is shipped with the following audio prompts and messages:

Table 6-16: Default IVR Messages

Message Type	Message Text	File Name
Welcome (unified)	"Welcome to Polycom Conferencing."	WELCMPNS.ACA
Connecting to conference	"You are now being connected to your conference."	CONFCONN.ACA
Conference password request	"Please enter the conference password. Press the pound key when complete."	CONFPASS.ACA
Conference password failure	"Invalid conference password. Please try again."	CONFRTY.ACA
Disconnection Msg	"You are now being disconnected from the conference. Goodbye."	GOODBYE.ACA
Operator Assistance	"Please wait. The conference operator will assist you momentarily."	OPERHELP.ACA
NID: Conference ID Request	"Please enter your conference ID. Press the pound key when complete."	CNFIDRQS.ACA
NID: Conference ID failure indication	"Invalid conference ID. Please try again."	CNFIDFL.ACA
Leader: Chairperson identifier request	"For conference chairperson services, press the pound key. All other participants please wait..."	ENTRYOPT.ACA
Leader: Chairperson password request	"Please enter the conference chairperson password. Press the pound key when complete."	LEDRPASS.ACA
Leader: Chairperson password failure	"Invalid chairperson password. Please try again."	LEDRRTY.ACA

Table 6-16: Default IVR Messages (Continued)

Message Type	Message Text	File Name
Personal code request	"Please enter your personal code. Press the pound key (#) when complete."	PINRQST.ACA
Personal code failure	"Invalid personal code."	PINFAIL.ACA
Press any key	"Press any key to enter the conference."	ANYKEY.ACA
General: Conference Secured	"The conference is now secured."	SECURED.ACA
General: Conference Unsecured	"The conference is now in an unsecured mode."	UNSECURE.ACA
General: Wait for chairperson	"Please wait for the chairperson to join or start the conference."	LDRWAIT.ACA
General: First to join	"You are the first person to join the conference."	FIRST.ACA
General: Indication of a "Mute all but me" operation	"All conference participants are now muted."	ALLMUTE.ACA
General: Indication of a "Un Mute all but me" operation	"All conference participants are now unmuted."	ALLUNMTE.ACA
General Chairperson dropped	"The chairperson has left the conference."	CHAIRDRP.ACA
General: End time alert	"The conference is about to end."	ENDALERT.ACA

Table 6-16: Default IVR Messages (Continued)

Message Type	Message Text	File Name
General: Change password menu	"Press 1 to change conference password. Press 2 to change chairperson password. Press 9 to exit the menu."	PINCHANG.ACA
General: Enter new conference password	"Please enter the new conference password. Press the pound key (#) when complete."	NEWPIN.ACA
General: Enter new chairperson password	"Please enter the new chairperson password. Press the pound key (#) when complete."	NEWCHAIR.ACA
General: Re-enter new chairperson password	"Please re-enter the new password. Press the pound key (#) when complete."	NEWCNFRM.ACA
General: New password invalid	"The new password is invalid."	NEWINVLD.ACA
General: Successful password change confirmation	"The password has been successfully changed."	NEWOK.ACA
General: Conference locked	"The conference is now locked."	LOCKED.ACA
General: Conference unlocked	"The conference is now unlocked."	UNLOCKED.ACA
General: Destination conference is locked	"The conference you are trying to join is locked."	CUFLOCKD.ACA
General: Billing code request (during on going conference)	"Please enter the Billing code. Press the pound key (#) when complete."	BILLING.ACA

Table 6-16: Default IVR Messages (Continued)

Message Type	Message Text	File Name
General: Self mute indication	"You are now muted."	SELFMUTE.ACA
General: Self unmute indication	"You are no longer muted."	MUTEEND.ACA
General: Max. number of Conf. participants exceeded	"The conference is full. You cannot join at this time."	CNFFULL.ACA
General: "Add me to Q&A queue" confirmation	"Please wait and you will be prompted to ask your question."	QAADD.ACA
General: "Remove me from Q&A queue" confirmation	"You have been removed from the Question and Answer queue."	QAREM.ACA
General: "Next participant in Q&A queue" announcement (Grant permission to ask)	"It is now your turn to speak - please ask your question."	QAASK.ACA
General: Recording indication	"The conference is being recorded."	RCRDCONF.ACA
General: Recording failure indication	"The conference recording has failed."	RCRDFAIL.ACA

Table 6-16: Default IVR Messages (Continued)

Message Type	Message Text	File Name
General: Chairperson Help menu1	<p>"The available touch-tone keypad actions are as follows:</p> <ul style="list-style-type: none"> • To exit this menu press any key. • To request private assistance, press Star (*), 0. • To request operator's assistance for the conference, press 0, 0. • To mute your line, press star (*), 6. • To unmute your line, press pound (#), 6. 	LDRHP1A.ACA
General: Chairperson Help menu2 (continuation)	<ul style="list-style-type: none"> • To lock the conference to dial-in participants, press star (*), 7. • To unlock the conference, press pound (#), 7. • To increase your volume, press star (*), 9. • To decrease your volume, press pound (#), 9. • To mute all participants except yourself, press star (*), 5." 	LDRHP2.ACA

Table 6-16: Default IVR Messages (Continued)

Message Type	Message Text	File Name
General: Participant Help menu	“The available touch-tone keypad actions are as follows: <ul style="list-style-type: none"> • To exit this menu press any key. • To request private assistance, press star (*), 0. • To mute your line, press star (*), 6. • To unmute your line, press pound (#), 6. • To increase your volume, press star (*), 9. • To decrease your volume, press pound (#), 9. • To ask a question, press star (*), 2, 2. • To cancel your question, press pound (#), 2, 2.” 	PRTCHP.ACA

Table 6-16: Default IVR Messages (Continued)

Message Type	Message Text	File Name
General: Invite Help menu	<p>"The available touch-tone keypad actions are as follows:</p> <ul style="list-style-type: none"> • To exit this menu press any key. • To obtain an outside line and dial out to an invitee, press star(*), 4. • To admit an invitee to the conference and invite another participant, press star(*), 1. • To disconnect the invitee and invite another participant, press star(*), 2. • To admit an invitee to the conference and return to the conference, press star(*), 3. • To disconnect the invitee and return to the conference, press star(*), 4." 	INVITHP.ACA
General: Voting Help menu	<p>"The available touch-tone keypad actions are as follows:</p> <ul style="list-style-type: none"> • To exit this menu press any key. • To vote, press star(*)r, 8, 1. • To end the voting session and get the results, press pound (#), 8, 1. • To start a new voting session, press star(*)r, 8, 2. • To cancel the voting session, press pound (#), 8, 2." 	VOTEHLP.ACA

Table 6-16: Default IVR Messages (Continued)

Message Type	Message Text	File Name
Roll Call: User name recording request	"After the tone, please state your name."	NAMERCRD.ACA
Roll Call: Playing the recorded name for the user to get confirmation	"The name you have recorded is...(here the system will play the name)"	NAMEIS.ACA
Roll Call: Name recording confirmation	"Press one to record your name again or remain on the line to enter the conference."	RERECRD.ACA
Roll Call: Participant's entry prompt	"...has joined the conference."	JOINED.ACA
Roll Call: Participant's exit prompt	"...has left the conference."	LEFT.ACA
Roll Call: Introduction to the participant's list prompt	"The conference participants are..."	ROLLCALL.ACA
Roll Call: End of Roll Call list.	"This is the end of the participants list"	LISTEND.ACA
SilenceIT: Adjust SilenceIT sensitivity and unmute	"To reduce the noise detection level and return to the conference, press 3."	SLNRDRT.ACA
SilenceIT: Disable SilenceIT and unmute	"To disable noise detection and return to the conference, press 4."	SLNDNDRT.ACA
SilenceIT: SilenceIT menu	"Your line is muted due to a noisy line. For available options, press 9."	SLNMUTE.ACA

Table 6-16: Default IVR Messages (Continued)

Message Type	Message Text	File Name
SilenceIT: Return to the conference muted	"To return to the conference muted, press 2."	SLNRTMUT.ACA
SilenceIT: Unmute and return to the conference	"To unmute and return to the conference, press 1."	SLNUNMTR.ACA
SilenceIT: Unmute reminder	"To unmute your line at any time, press pound (#), 6."	SLNUNMUT.ACA
SilenceIT: Participant detected as noisy indication to the conference	"... line is muted due to a noisy line."	PARTDET.ACA

Attended Conferencing

An operator Attended conference is a service designed usually for large conferences and can contain both dial-in and dial-out participants. In many attended conferences, the name and the telephone number of each dial-out participant is given to the operator at the time the reservation is made. For dial-in participants, the Entry Queue used for conference access, or the IVR service assigned to the conference, are set to attended mode. Using the enhanced tools for attending participants, conferences, the operator or coordinator makes sure all invited participants are on hand, then sees to it that the conference proceeds according to plan. Usually, the operator initiates the call to connect participants and greets the participants when connected.

In Attended conferences, the operator can assist participants by greeting and guiding them to the appropriate conference, or by helping them join the conference if they have failed to enter the required information (password).

When dial-in participants connect to an Entry Queue or IVR-enabled conference they initially hear a welcome message. If the Entry Queue or IVR-enabled conference is set to attended mode (the Entry Queue Service or the IVR Service is configured to “Wait for Operator Assistance”), they are then moved to the Participants Queue where they must wait for an operator to attend to them.

The participants can be in one of the following stages: Greeting (Welcome), Attended, On Hold, and Conferencing. The operator controls the participants’ connections to the conference moving them from one stage to another. Special icons are used to indicate the participant status in an attended conference.

Greeting - In the *Greeting* stage, participants connect to the Entry Queue or directly to an IVR-enabled conference. They hear a *Welcome* message and are then moved to the Participants Queue where they wait for the operator to connect them to the conference.

Attended - In the *Attended* stage, participants are moved to the Operator conference, where after a short conversation with the participant, the operator moves each participant to the appropriate conference (Home conference) or places them on hold. An Operator conference is a conference, that allows the operator and one participant to talk without disturbing the On Going Conference. For more details see “Managing Attended Participants from the Browser, Status and Monitor Panes” on page 7-34.

On Hold - In the *On Hold* stage, participants wait in the Participant’s Queue where they hear background music, view the same *Welcome* video slide, and wait for the operator’s assistance. Participants are also placed on hold and moved to the Participant’s Queue when they enter the wrong conference Numeric ID (while in the Entry Queue) or the wrong password. This option must be enabled in the Entry Queue or the IVR Service and an Operator conference must be running on the MCU.

Conferencing - In the *Conferencing* stage, the participant is already connected to the On Going Conference. During the conference, operator assistance can be requested via DTMF codes, but only if it is already configured in the IVR Service assigned to the conference. For information about configuring IVR Services, refer to see Chapter 6, “Setting IVR Message Services” on page 6-16.

Requirements for an Attended Conference

A conference can be defined set as attended or unattended by setting the IVR Service to attended mode.

In such a conference, the connection to the conference is managed by the operator, as well as the operations performed during the conference such as managing the Question and Answer session, voting, muting and unmuting participants, and more.

An Operator conference is required to manage the connection to attended conferences.

An Operator conference can have up to two participants only: the operator and a participant. The operator can move a participant from the Entry Queue, conference IVR Queue, Participants Queue, or On Going Conference to a private, one-on-one conversation in the Operator conference by selecting or clearing the "On-hold for Operator Assistance" option in the Entry Queues Service assigned to the entry queue. If the conference is accessed from the Entry Queue, the connection to the conference is set to attended mode.

To run attended conferences the following entries must be set:

Table 7-1: Attended Conference Entities

Entity	Description
<i>An ongoing Operator conference</i>	<p>An Operator conference is a side conference that enables the operator to assist participants without disturbing the On Going Conferences and without being heard by other conference participants. It can have up to two participants only - the operator and the participant. It must be running before the attended conference is set up.</p> <p>The Operator Conference is required when:</p> <ul style="list-style-type: none"> • The operator needs to talk to the participant to obtain the participant's personal information, such as name, email address, etc. • To manage the participants waiting in the participants Queue. • When the participant has requested help and the operator wants to talk to him/her.

Table 7-1: Attended Conference Entities (Continued)

Entity	Description
<i>IVR Service set to Wait for operator assistance</i>	The IVR Service assigned to the conference must be set to <i>On Hold for Operator Assistance</i> in the <i>Welcome Message</i> dialog box. In this mode, when the participants connect to the conference, they are automatically moved to the Participants Queue.
<i>EQ service set for Wait for operator assistance</i>	The Entry Queue Service assigned to the attended Entry Queue must be set to <i>On Hold for Operator Assistance</i> option in the <i>Welcome Message</i> dialog box. In this mode, when the participants connect to the Entry Queue, they are automatically moved to the Participants Queue where they wait for the operator to connect them to the conference.

Defining an Operator Conference

You can define an Operator Conference directly or define an operator reservation. The Operator conference name is derived from the operator name currently connected to the MCU from the same workstation.

To define an On Going Operator conference:

1. Right-click the *On Going Conferences* icon, and then click **New Operator Conference**.

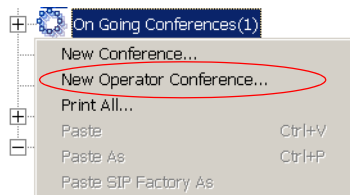

The *Conference Properties – General* dialog box opens.

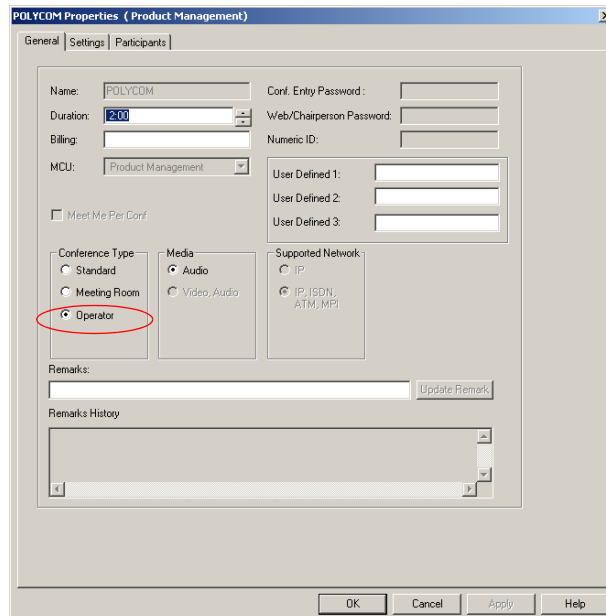

The conference type is set to **Operator**. The name of the On Going Operator Conference or Reservation is taken from the Operator's login name. This name cannot be modified. No password is required.



Only one Operator Conference can be run for each login operator at any time.

2. You can modify the conference duration.
3. In the *Media* box, select **Audio** to create an Audio Only Operator conference.
4. Click the **Settings** tab.
The *Conference Properties – Settings* dialog box opens.

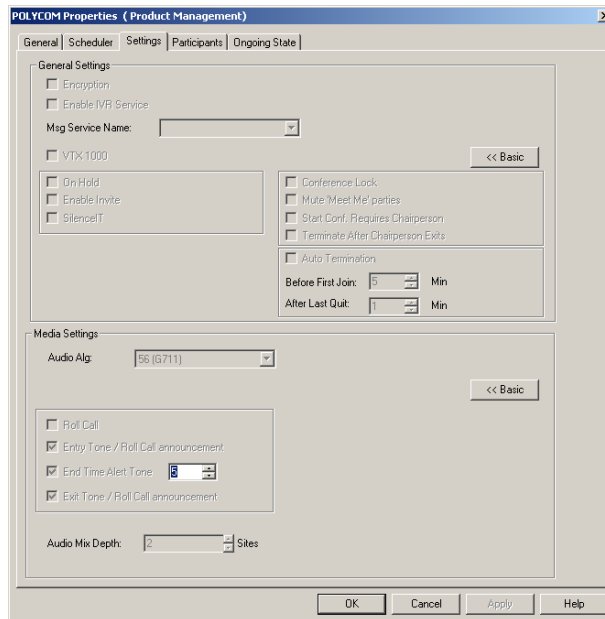

In an Operator conference, all fields not relevant to the Operator conference such as IVR Service are disabled.

- Click the **Participants** tab.
The *Conference Properties – Participants* dialog box opens.

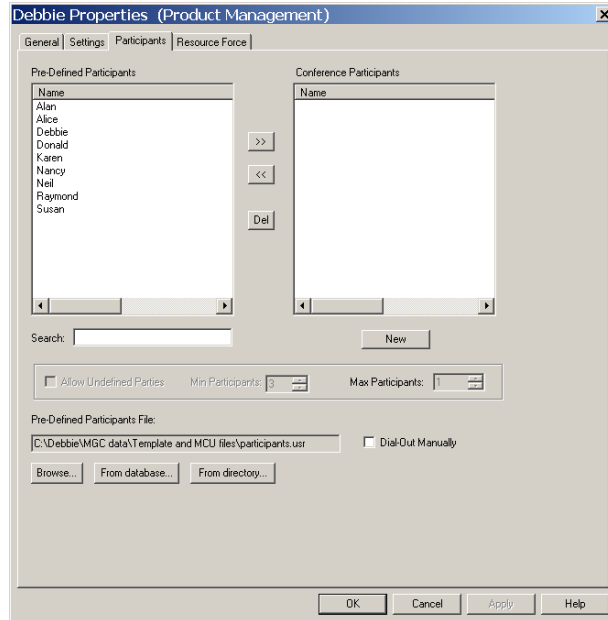

In an Operator Conference, one participant must be defined - the operator. The operator adds the second participant interactively during an On Going Conference.

- Define the operator as a new participant, or if the operator is already defined in a Participant Template file or in the Participant database, add the operator to the conference.

7. Click **OK**.

The Operator conference is added to the list of On Going Conferences.

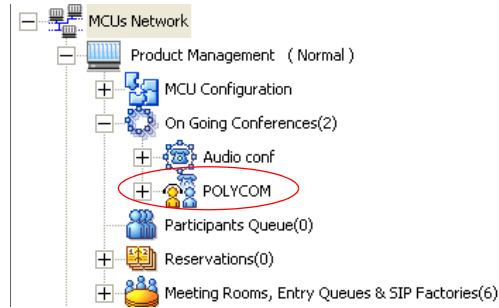

To save this conference for future use, copy the conference to a Group in the Reservations database by selecting the Copy Conf. option from the right-click pop-up menu. For more details, see the MGC Manager User's Guide, Volume II, Chapter 8, "Templates Handling".

The Audio Only Operator conference is identified by the icon:



- Audio Only Operator conference.

The *Operator* icon  is used to identify the operator participating in an Operator conference.

Setting the Participants Connection to the Conference to Attended Mode

The participant connection to the conference is set to Attended Mode either at the Entry Queue level (if the conference is accessed from the Entry Queue) or at the conference level (if the conference is accessed directly via an IVR Queue).



If a conference is accessed via an Entry Queue and an IVR Service is also assigned to the conference, the attended mode is set only for the entry queue. The Attended Mode is set for a conference only when dial-in participants connect to it directly.

Setting the Entry Queue to Attended Mode

To set the Entry Queue to Attended Mode you define an Entry Queue Service in which the “On-hold for Operator Assistance” option is selected in the Welcome dialog box.

For a detailed description of the Entry Queue Service definition see Chapter 6, “Defining a New Entry Queue Message Service”.

This Entry Queue Service must be assigned to the Entry Queue which will be used for attended dial-in connections to conferences.

Setting the Conference Connection to Attended Mode

The connection to the conference is set in the IVR Service assigned to the conference by selecting “On-hold for Operators Assistance” in the *IVR - Welcome Message* dialog box.

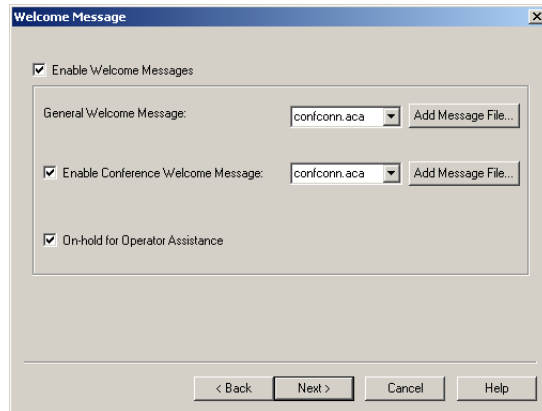

This IVR Service is then assigned to the conference to which dial-in participants connect and are assisted by the operator.

Participants Queue Management

The Participants Queue window lists all the participants waiting for the operator's assistance. Participants are automatically added to the Participants Queue in the following circumstances:

- The IVR/Entry Queue Service is set to attended mode (On-hold for Operator assistance) and the operator is required to connect the participant to the conference
- The participant fails to connect to the conference by entering the wrong conference Numeric ID or conference password and waits for the operator's assistance
- The participant requests Operator's Assistance during the On Going Conference
- The participant is placed on hold

The Participants Queue provides robust tools for the operator to manage participants waiting for assistance. The Participants Queue is organized in one list. Participants waiting in the Participants Queue can be listed in the *Status* pane, or in a separate window. This enables you to list the On Going Conferences in the *Status* pane while assisting the participants waiting in the Participants Queue.



The Participants Queue management options are available only if an Operator conference is active and running on the MCU.

The main working tool is the *Attended Participant* dialog box that opens when a participant is being attended by the operator. This dialog box enables the operator to enter the participant name, general information, indicate the participant status (VIP yes/no), change the listening or broadcasting volume and move the participant to the destination conference (Home conference). The Attended Participant dialog box also provides tools to easily search filter the list of On Going Conferences for the appropriate destination conference, create a new On Going Conference, start an existing Meeting Room, and place a participant on hold. When moving the participant to the destination conference, the next participant waiting in the Participants Queue can be automatically moved to the Operator conference (to the Attended stage) speeding up the operator's work.

Listing Participants in the Participants Queue Window

The Participants Queue list contains all the participants who are currently waiting for operator assistance and the participant who is currently being assisted by the operator in the Operator conference.



When starting the MGC Manager for the first time in a new installation or after upgrading to a higher version, the Participants Queue window is automatically displayed (empty). To bring the window on top, select the *Participants Queue window* in the window menu.

To display the Participants Queue window:

- On the *Main* toolbar, click the *Participants Queue Window* icon .
- In the *Browser* pane, double click the Participants Queue icon

The *Participants Queue* window opens.

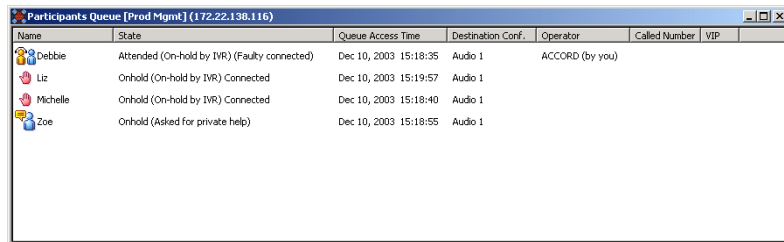

The following participant parameters are displayed in the *Participants Queue* window:

Table 7-2: Participants Window Columns

Column	Description
<i>Name</i>	The participant's name and an icon indicating the participant status. Possible statuses are <i>On Hold</i> , <i>Attended</i> , or <i>Wait</i> . For more information about participant statuses, see Chapter 3, "Additional Participant Statuses"
<i>State</i>	The reason the participant is moved to the Participants Queue, and the connection status.
<i>Queue Access Time</i>	The date and time the participant has entered the Participants Queue.

Table 7-2: Participants Window Columns (Continued)

Column	Description
<i>Destination Conference</i>	The name of the destination conference, when known, or the name of the Entry Queue to which the participant has connected. The conference name is known when the participant was connected to the conference and is moved from the conference to the Participants Queue or the Operator conference. For example, when the participant has requested assistance.
<i>Operator</i>	The login name of the operator who is assisting the participant. This information is useful when there are several operators logged into the same MCU from different computers.
<i>Called Number</i>	The number the participant has dialed. Usually identifies the dial-in number assigned to the Entry Queue or Meeting Room.
<i>VIP</i>	Indicates whether the participant status is defined as VIP.

The *Participants Queue* window can be moved to any position on screen and you can configure its size as you can do with the MGC Manager Main Window and the Templates window.





The new placement of the window at the time you close the MGC Manager application is saved for the next time you start MGC Manager - it is displayed in the same location.

Participants Queue Toolbar

The *Participants Queue* toolbar is enabled when an Operator Conference is running and a Participant icon or Operator icon is selected.

The *Participants Queue* toolbar contains the following buttons:

Table 7-3: Participants Queue Toolbar Buttons

Button	Function	Description
	<i>Attend Participant</i>	Moves the participant to the Operator conference for operator's assistance.
	<i>Place Participant on Hold</i>	Places the attended participant on Hold. The participant hears an IVR message while on hold.
	<i>Move to Home Conference</i>	Moves the participant to the Home (destination) conference.

Participant Queue Filter Toolbar

The *Participant Queue Filter* toolbar options enable displaying the list of participants who are waiting to be connected to the conference, according to selected criteria.

Table 7-4: Participant Queue Filter Toolbar Buttons

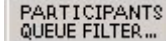
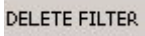
Button	Function	Description
	<i>Participant Queue Filter List</i>	Lists the Participant Queue filters currently defined in the system.
	<i>Participant Queue Filter</i>	Opens the <i>Participants Queue Filter</i> dialog box where you define a new Participants Queue Filter.
	<i>Delete Filter</i>	Deletes the selected Participant Queue Filters.

Using Participants Queue Filters

You can determine the types of participants to be displayed in the *Participants Queue* window by creating filters that set criteria according to which participants appear in the list.

Use the *Participants Queue* window to view participants connecting to a specific Entry Queue according to the Entry Queue's dial-in number, or according to a specific status.

Filters may be used in two modes: when you are connected to the database and locally without logging into the database.

When you are connected to the database, filters created and saved in the past may be used for the current session.

If you are not connected to the database, you can only create a filter to be used immediately and locally - without being able to save the filter for future use or add it to the list of filters.

Two types of filters may be defined: Personal Filters and Public Filters. Personal Filters are created by operators for their personal use.

Public Filters can only be defined by a database user with permission to create Public filters and who has logged into the database.



For more details about defining permissions to create public filters, see the MGC Manager User's Guide, Vol. II, Chapter 6, "Defining Permissions".

To define Participants Queue filters in the Database:

The default *Filter* is **All** - all participants waiting in the Participants Queue appear in the *Participants Queue* window. You can create a new filter and save it for future use.

1. If you are not already logged in, log into the database.
2. In the MGC Manager window, from the *Filter* toolbar, in the *Filter* list select **New Filter**.



3. Click the **Participants Queue Filter** button.



The *Participants Queue Filter* dialog box opens.

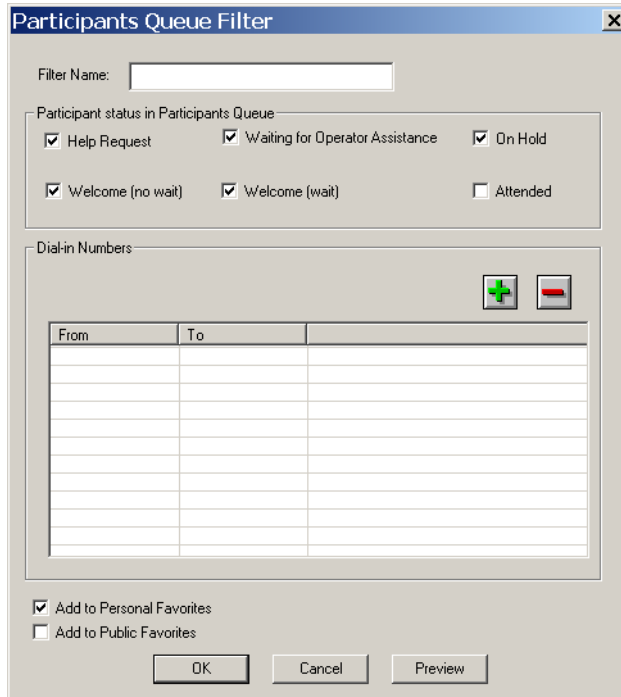

4. Enter the Filter name to save it in the database for future use.
Define the filtering options. You can select from the listed statuses of participants to be monitored or the participants who dialed the indicated dial-in numbers.

You can define the following filtering parameters.

Table 7-5: Participants Queue Filter Options

Field/Option	Description
<i>Filter Name</i>	Enter the name of the Filter. If you are modifying the parameters of an existing filter, enter a new name to modify the filter name.
Participant Status in Participants Queue	
<i>Help Request</i>	Select this check box to display participants who have requested help in the <i>Participants Queue</i> window.
<i>Waiting for Operator Assistance</i>	Select this check box to display participants who are waiting for the Operator Assistance because they failed to enter the correct conference numeric ID, Conference or Chairperson password, or because they need to be connected to the conference as the Entry Queue Service or IVR Service is set to attended mode.
<i>On Hold</i>	Select this check box to display participants who have been placed on hold.
<i>Welcome (no wait)</i>	Select this check box to display participants who are in Welcome (no wait) status. (for Greet and Guide conferences)
<i>Welcome (wait)</i>	Select this check box to display participants who are in Welcome (wait) status. (for Greet and Guide conferences)
<i>Attended</i>	Select this check box to display participants who are currently being attended.
Dial-In Numbers	
<i>Dial-In Numbers</i>	Define the dial-in numbers used by participants to access Entry Queues, Meeting Rooms, or conferences. Only participants dialing these numbers are displayed in the <i>Participants Queue</i> window.

Table 7-5: Participants Queue Filter Options (Continued)

Field/Option	Description
<p><i>Dial-In Numbers</i> (cont.)</p>	<p>To define the dial-in numbers:</p> <ol style="list-style-type: none"> Click the plus [+] icon to add a range of dial-in numbers. The <i>Add Dial-in Range</i> dialog box opens.  <ol style="list-style-type: none"> In the <i>First Phone Number</i> box enter the first dial-in number in the range of numbers to be used for filtering. In the <i>Last Phone Number</i> box enter the last dial-in number in the range of numbers to be used for filtering. To use one number, enter the same dial-in number in the <i>First</i> and <i>Last Phone Number</i> boxes. Click OK. The dial-in numbers range appears in the <i>Participants Queue Filter</i> dialog box. <p>Repeat steps 1-4 to define additional dial-in number ranges to be filtered.</p> <p>To remove a range of dial-in numbers, select the range to remove and click the minus [-] icon.</p> <p>When no dial-in number ranges are defined in the filter, dial-in number is not used as a criterion for displaying a participant in the <i>Participants Queue</i> window.</p>

Table 7-5: Participants Queue Filter Options (Continued)

Field/Option	Description
Actions	
<i>Add to Personal Favorites</i>	This check box is selected by default. Select this check box to save the filter for future use and add it to the list of filters that you can use. When viewing the list of Filters in the <i>Filter</i> list in the MGC Manager Toolbar, the Filters are labeled Personal: [Filter Name] . Note: This option appears only when creating the filter in the database.
<i>Add to Public Favorites</i>	This check box appears only if you have the permission to create/modify Public filters. Select this check box to save this Filter as a Public Filter for use by all users. When viewing the list of Filters in the <i>Filter</i> list in the MGC Manager Toolbar, Public Filters are labeled Public: [Filter Name] . Note: This option appears only when creating the filter in the database.

5. Once the filter is defined, you can preview its selection by clicking the **Preview** button.
6. If you want to further modify it, do so or save the filter for future use by selecting the *Add to Favorites* option.
7. Click the **Preview** button to apply the filter to the *Participants Queue* before saving it and adding it to the *Favorites* list.
8. If you are not satisfied with the filtering options, you can modify them and preview the results before saving the filter.
9. Click **OK** to save the filter in the *Favorites* list.

To use filters:

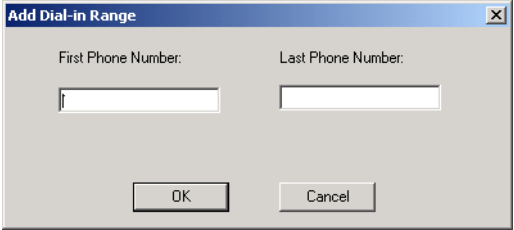
You can filter the list of participants displayed in the *Participants Queue* window at any time by selecting a different filter from the list of saved filters.



You must be logged into the appropriate databases to use existing, pre-defined filters. For more information on how to log into the database see MGC Manager User's Guide Vol. I, Chapter 3, "Templates Database".

- To filter the *Participants Queue* window, select a filter from the list.

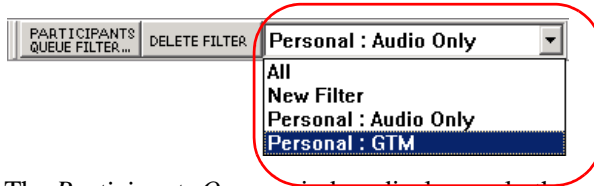

The *Participants Queue* window displays only the participants that match the selected filter.

To modify a filter:

You can modify your personal filters or public filters, if you have the appropriate permission and you are logged into the database.

1. In the *Filters* list, select the filter to modify and then click the **Participants Queue Filter** button. The *Participants Queue Filter* dialog box opens.
2. Select or deselect any of the filter criteria as needed.
3. Click the **OK** button.

To delete a filter:

You can delete a personal filter or a public filter (if you have the appropriate permission and you are logged into the database).

1. In the *Filters* list, select the filter to delete, and then click the **Delete Filter** button. A confirmation dialog box opens.

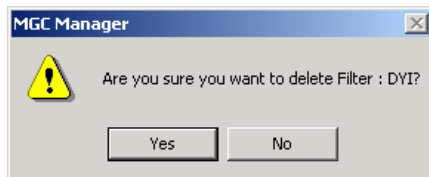

- Click **Yes** to confirm the deletion.
The filter is removed from the *Filters* list.

The Attended Participants Dialog Box

To connect participants waiting in the Participants Queue to the appropriate conference, the operator must move the participant to the Operator conference (Attend state) to talk to the participant and find out the name or details of the destination conference. In addition the operator usually needs to enter the participant's general parameters such as name, email, billing information, and more. Once the information is entered and the target conference is identified, the participant is moved to that conference, and the operator moves the next participant in line to the Operator conference.



An active Operator conference must run on the same MCU as the Participants Queue to be able to assist Participants waiting in the Participants Queue.

To move a participant to the Operator conference:

- In the *Participants Queue list* (in the *Browser* pane) or in the *Participants Queue* window, double-click the icon of the participant you want to move to the Operator conference.

The participant is automatically moved to the Operator conference and the *Attended Participant* window opens.

Attended Participant (Karen)

Attended Participant:
 Participant Name: VIP Chair Person
 User Defined 1: User Defined 3:
 User Defined 2: User Defined 4: Disconnect
 Broadcasting Volume(S) Listening Volume(S) Apply

Operator:
 Broadcasting Volume(S) Listening Volume(S)
 Join End Join Mute Audio

Conferences:
 Search Value: Search In:

Conference Name	Number	Id	User Defined 1	User Defined 2	User Defined 3	Start Time	Meeting Type
4CIF	2228					Sep 18, 2005 0...	Ongoing Meeting
Budget	2930		Polycorn	Finance		Sep 19, 2005 0...	Ongoing Meeting

 New Conference... Start Meeting Room

Action options:
 Auto Attend Next Participant Next By: Include On Hold Participants
 To Home Conf /F3 Hold /F4 Move /F5 Next /F6 Close

In the *Attended Participant* box, enter the participant name, and general information (*User Defined* fields), change the participant status to VIP and/or chairperson, and modify the listening and broadcasting volumes.

In the *Operator* box, you can modify your listening and broadcasting volumes.

In the *Conferences* box, you can list all the On Going Conferences, Meeting Rooms, and Reservations, depending on the selected listing criteria and search the list for the required destination conference.

Once the destination conference is located, you can move the participant to that conference or place the participant on hold.

If the *Auto Attend Next Participant* check box is selected, the next participant waiting in the Participants Queue is automatically moved to the Operator conference when the current attended participant is moved out of the Operator conference (either to the destination conference, placed on hold, or disconnected).

The following parameters and functions are displayed in the *Attended Participants* dialog box:

Table 7-6: Attended Participant Dialog Box Fields

Field/Option	Description
Attended Participant	
<i>Participant Name</i>	If the participant is undefined, the system-assigned participant name is displayed in this field. Type the name of the participant, using up to 80 characters.
<i>VIP</i>	Select this check box to change the participant status to VIP.
<i>Chairperson</i>	Select this check box to designate this participant as the conference Chairperson.

Table 7-6: Attended Participant Dialog Box Fields (Continued)

Field/Option	Description
<i>User Defined 1-4 (Title)</i>	<p>In any or all of the four <i>User Defined</i> fields, enter general information for the participant, such as the participant's email address, telephone number, company name, location, or any required information.</p> <p>The titles of the <i>User Defined</i> fields can be modified in the <i>Database Manager -> Defaults -> User Defined Defaults</i> and loaded to the MGC Manager application. For details of defining the titles see the MGC Manager User's Guide, Volume II, Chapter 6 "Defaults". For a description on how to load the user defined default titles, see MGC Manager User's Guide Vol. I, Chapter 3, "Loading the User Defined Default Set to the MGC Manager Application".</p>
<i>Broadcasting Volume</i>	<p>If necessary, adjust the level of sound transmitted by this participant, heard by the operator (and later by other participants).</p> <p>To adjust the volume, move the slider. The volume scale is from 1 to 10, where 1 is the weakest and 10 the strongest volume. The volume of each endpoint's audio at connection time is set to 5. One movement of the volume slider increases or decreases the volume by one unit, equivalent to 3db.</p>
<i>Listening Volume</i>	<p>If necessary, adjust the level of sound heard by this participant.</p> <p>To adjust the volume, move the slider. The volume scale is from 1 to 10, where 1 is the weakest and 10 the strongest volume. The volume of each endpoint's audio at connection time is set to 5. One movement of the volume slider increases or decreases the volume by one unit, equivalent to 3db.</p>
<i>Disconnect</i>	<p>Click this button to disconnect the participant from the MCU.</p>

Table 7-6: Attended Participant Dialog Box Fields (Continued)

Field/Option	Description
<i>Apply</i>	If you have modified any of the participant volume levels (Broadcasting or Listening), click this button to apply the changes and affect the participant volume. If any of the other participant properties were modified, click this button to update the <i>Participant Properties - Identification</i> parameters.
Operator	
<i>Broadcasting Volume</i>	If necessary, adjust the level of sound transmitted by the operator to this participant.
<i>Listening Volume</i>	If necessary, adjust the level of sound heard by the operator.
<i>Join</i>	This option enables the operator to join the conference for a short announcement. To join a conference, select the conference in the <i>Conferences list</i> and then click this button.
<i>End Join</i>	Click this button to end the Join operation.
<i>Mute/Unmute Audio</i>	Click this button to mute the operator's audio.
Conferences	
<i>Search Value</i>	Enter the first letters of a conference name or the information in one of the <i>User Defined</i> fields to determine the conferences to be listed according to the selected <i>Search In</i> criteria.

Table 7-6: Attended Participant Dialog Box Fields (Continued)

Field/Option	Description
<i>Search In</i>	<p>Select the list to be used to search for the destination conference according to the <i>Search Value</i>.</p> <ul style="list-style-type: none"> • Ongoing meetings - the system searches for the destination conference in the list of On Going Conferences running on the connected MCU. • Ongoing meetings + 12h reservations - the system searches for the destination conference in the list of On Going Conferences and Reservations scheduled to start in the next 12 hours on the connected MCU. • Ongoing + MRs - the system searches for the destination conference in the list of On Going Conferences and Meeting Rooms on the connected MCU. • All: Ongoing Meetings + 12h + MRs - the system searches for the destination conference in the list of On Going Conferences, Meeting Rooms and Reservations scheduled to start in the next 12 hours on the connected MCU.
<i>Conferences List</i>	<p>This table displays the search result according to the <i>Search Value</i> and <i>Search In</i> criteria.</p> <p>To move the participant to the destination conference, select the conference from the list and then click the Move button (or use the displayed shortcut key).</p> <p>Note: if the participant's destination conference is known, for example when the participant has requested help, the destination (Home) conference is automatically listed. Click the To Home Conf button to move the participant back to his/her original conference.</p>
<i>New Conference</i>	<p>Click this button to create a new On Going Conference and move this participant to it. The <i>Conference Properties - General</i> dialog box opens, letting you define the conference parameters.</p>

Table 7-6: Attended Participant Dialog Box Fields (Continued)

Field/Option	Description
<i>Start Meeting Room</i>	<p>You can move a participant to a Meeting Room only if the Meeting Room is active. However, the first participant connecting to the Meeting Room cannot be moved from the attended Participants Queue to the Meeting Room unless it is first manually activated.</p> <p>To manually activate a Meeting Room:</p> <ol style="list-style-type: none"> 1. In the <i>Search In</i> list, select an option to list Meeting Rooms. 2. In the <i>Conferences</i> list, select the Meeting Room to activate and then click the Start Meeting Room button.
Actions	
<i>Auto Attend Next Participant</i>	<p>Select this check box to automatically attend to the next participant in line. When the current attended participant is moved to his/her destination or Home conference, the system automatically moves the next participant in line to the Operator conference. The sequential order of participants in the queue is determined by the <i>Next By</i> selection.</p>

Table 7-6: Attended Participant Dialog Box Fields (Continued)

Field/Option	Description
<i>Next By</i>	<p>Determines the sort order of the Participants Queue. When the <i>Auto Attend Next Participant</i> is selected, this field determines who is the next participant in line that should be automatically moved to the Operator conference.</p> <p>The list may be sorted according to the following criteria:</p> <ul style="list-style-type: none"> • Time - The amount of time participants have been waiting in the <i>Participants Queue</i>. This is the default sorting criteria. When a participant is placed on hold, his/her time counter is reset. • Name - The <i>Participants Queue</i> list is sorted by the participant name. • VIP + Time - Participants identified as VIP are listed first (and the VIP list is sorted by time). The remaining (Standard) participants are sorted according to the amount of time they have been waiting in the queue. • Requested Help + Time - Participants that have requested the operator's assistance are listed first (and the list is sorted by time). The remaining (Standard) participants are sorted according to the amount of time they have been waiting in the queue. • VIP + Requested Help + Time - Participants identified as VIP are listed first (and the VIP list is sorted by time). Participants that have requested the operator's assistance are listed next. The remaining (Standard) participants are sorted according to the amount of time they have been waiting in the queue.

Table 7-6: Attended Participant Dialog Box Fields (Continued)

Field/Option	Description
<i>Include On Hold Participants</i>	Select this check box to include participants placed on hold in the list of participants to which the <i>Auto Attend Next Participant</i> option applies. When selected, the participants placed on hold will be attended according to the selected sort order (<i>Next By</i>), as all other participants waiting in the queue. When cleared, participants placed on hold will not be automatically moved to the Operator conference for assistance and you have to manually select them in the Participants Queue.
<i>To Home Conf. /F3</i>	Click this button to move the participant back to his/her Home conference when the participant was moved from the conference to the <i>Participants Queue</i> for assistance, or was placed on hold during the On Going conference. In this case the name of the Home conference is automatically displayed (and selected) in the conferences list.
<i>Hold /F4</i>	Click this button to place the participant on hold. When placed on hold, the participant hears background music and an icon indicating that the participant is on hold is displayed in the <i>Status</i> column of the <i>Monitor</i> and <i>Status</i> panes. In addition, the participant icon in the <i>Participants Queue</i> window changes to On Hold. Note: When placing a participant on hold, the waiting time in the queue is reset to zero.
<i>Move /F5</i>	Click this button to move the participant to the selected conference in the <i>Conferences</i> list.
<i>Next /F6</i>	This button is disabled when the <i>Auto Attend Next Participant</i> option is selected. Click this button to attend the next participant listed in the <i>Participants Queue</i> sorted according to the <i>Next By</i> criteria.
<i>Close</i>	Click this button to close the dialog box.



- Initially, the command buttons are displayed with the default shortcut keys. If you modify the shortcut key configuration, the command button shortcut key display is updated accordingly.
- You cannot close the *Attended Participant* dialog box when a participant is being attended (and is currently located in the Operator conference). To close this window you must first move the participant from the Operator conference to the destination conference (click the **Move** or **To Home Conf** button) while clearing the *Auto Attend Next Participant* check box.

Moving the Attended Participant to the Destination Conference

Two options are available to connect the participant to the destination conference:

- Move*
- To Home Conf*

To connect a participant to his/her destination conference:

- In the *Conferences* box of the *Attended Participant* window, select the destination conference of the attended participant, and then click the **Move** button.

Attended Participant (Karen)

Attended Participant

Participant Name: VIP Chair Person

User Defined 1: User Defined 3:

User Defined 2: User Defined 4:

Broadcasting Volume[5]: Listening Volume[5]:

Operator

Broadcasting Volume[5]: Listening Volume[5]:

Conferences

Search Value: Search In:

Conference Name	Numbrs Id	User Defined 1	User Defined 2	User Defined 3	Start Time	Meeting Type
ACF	2228				Sep 18, 2005 0	Ongoing Meeting
budget	2930	Polycor	Finance		Sep 19, 2005 0	Upcoming Meeting

Auto Attend Next Participant Next By: Include On Hold Participants

The participant moves to the selected conference.

Alternatively, press the selected shortcut key combination as it appears on the **Move** button (the default shortcut key is <F5>) or see Chapter 4,

“Moving a Participant from one Conference to Another” for additional options.

- If the participant’s conference is not running, you can click **New Conference** in the *Conferences* box to start a new conference for the participant, then select the conference and click **Move**.
- If the participant’s Meeting Room is not active, select the Meeting Room from the list and then click **Start Meeting Room**. Once the Meeting Room is active click **Move**.
- When you move the presently attended participant to his/her Home/destination conference and he/she is the last participant in the *Participants Queue*, the following message appears:

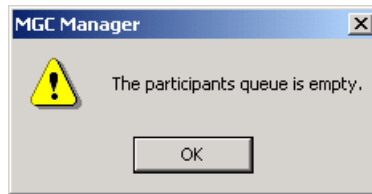

- If the *Participants Queue* includes only On Hold participants the following message is displayed:

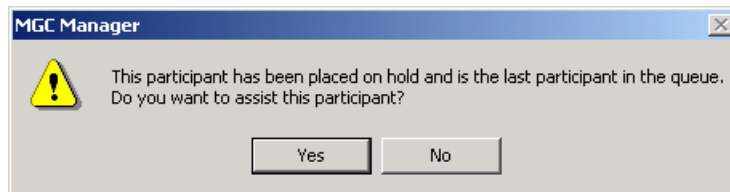

Click **Yes** to attend a participant that was placed on hold. Click **No** to leave the participant on hold in the *Participants Queue*.

To move a participant to the Home conference:

This option can be used only when the participant is moved from his/her original conference to the *Participants Queue* and you want to move him/her back to original conference.

In this case the name of the Home Conference is automatically displayed (and selected) in the *Conferences* list.

- In the *Attended Participant* window, click the **To Home Conf** button.

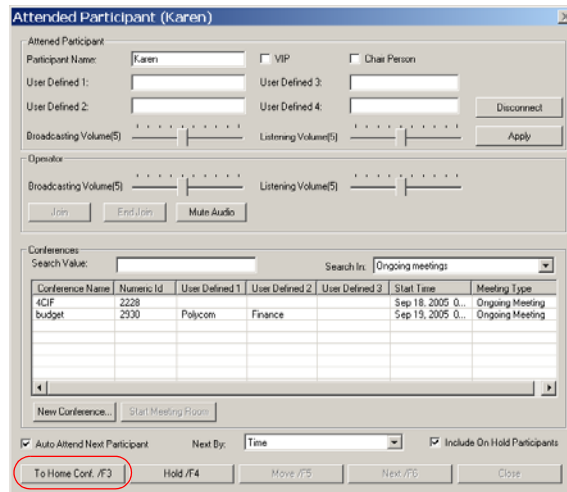

Alternatively, press the selected shortcut key combination as it appears on the **To Home Conf** button (the default shortcut key is <F3>) or see “Moving a Participant to the Home Conference” on page 7-37 for additional options.

- When you move the presently attended participant to his/her Home conference and he/she is the last participant in the *Participants Queue*, the following message appears:

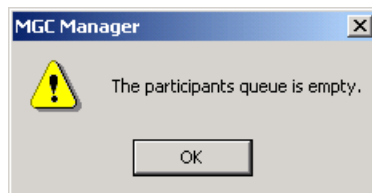

- If the *Participants Queue* includes only On Hold participants the following message is displayed:

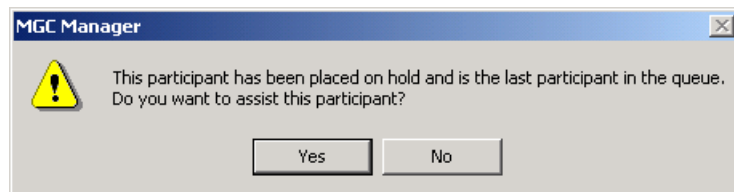

Click **Yes** to attend a participant that was placed on hold. Click **No** to leave the participant on hold in the *Participants Queue*.

To place a participant On Hold:

- In the *Attended Participant* window, click the **Hold** button.

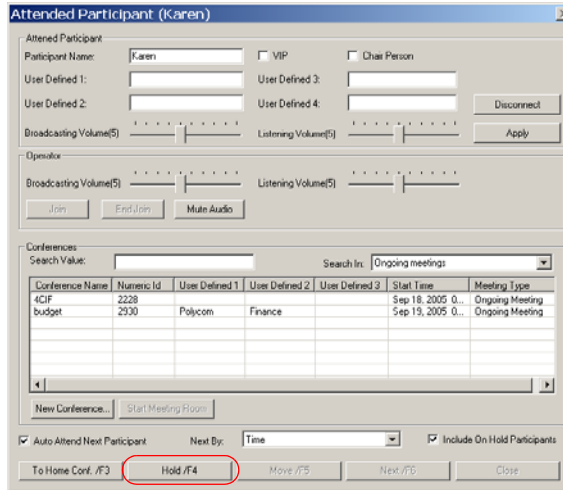

Alternatively, press the selected shortcut key combination as it appears on the **Hold** button (the default shortcut key is <F4>).

When you place a participant on hold who is the last participant in the *Participants Queue*, the following message appears:

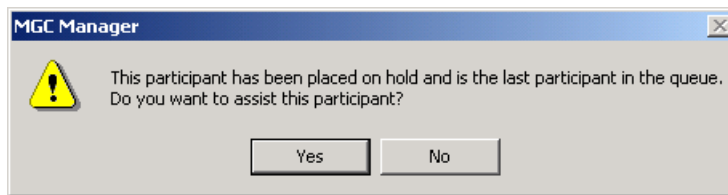

Click **Yes** to attend a participant that was placed on hold. Click **No** to leave the participant on hold in the *Participants Queue*.

Operator Joining a Conference

An operator can join a conference for a short announcement or to check the conference status.

To join a conference as operator:

- In the *Conferences* box of the *Attended Participant* window, select the conference you want to join, and then click the **Join** button in the *Operator* box.

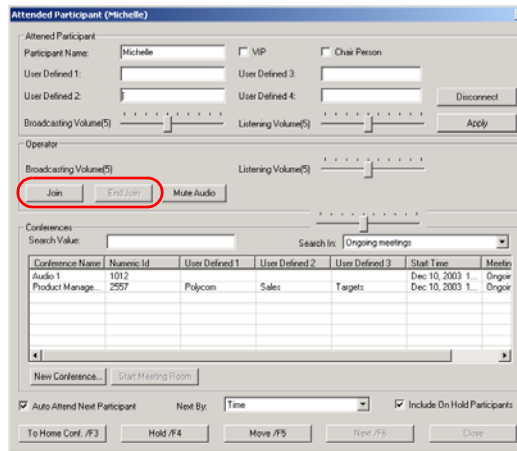

The operator joins the selected conference. Attended participants remain in the operator conference until the operator returns to the operator conference and moves them or places them on hold.

To end the Join state of the operator:

- In the *Operator* box of the *Attended Participant* window, click the **End Join** button.

The operator returns to the Operator conference.

Managing Attended Participants from the Browser, Status and Monitor Panes

The same operations that can be performed in the Participants Queue Window can also be performed when selecting participants in the *Browser, Status* and *Monitor* panes, using the following methods:

- Using the participant right-click menu
- Using the Attended Participant toolbar
- Using Shortcut keys
- Using drag and drop

Selecting the Participants to Manage

The participants can be selected from the following places:

- *Browser, Status, and Monitor* pane, *On Going Conference* list

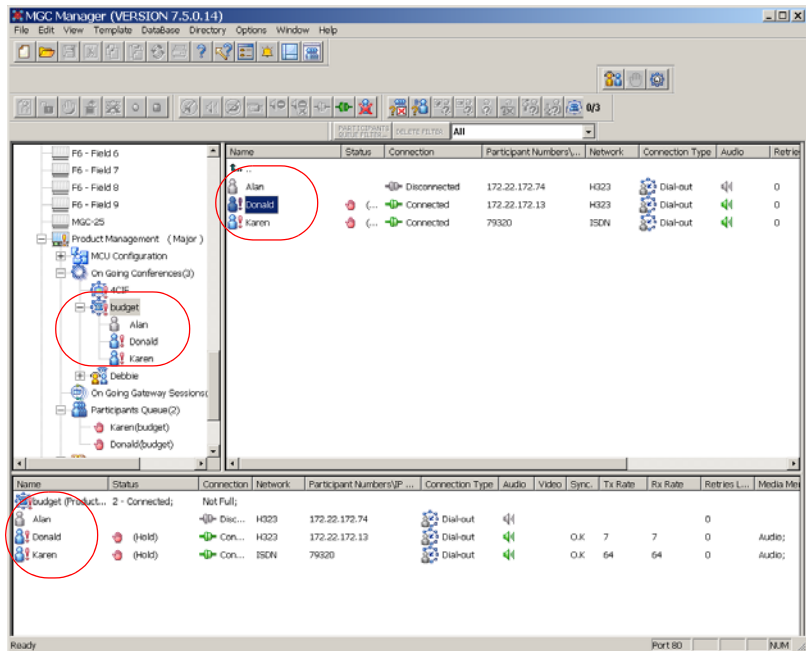

- *Browser and Status pane, Participants Queue list*

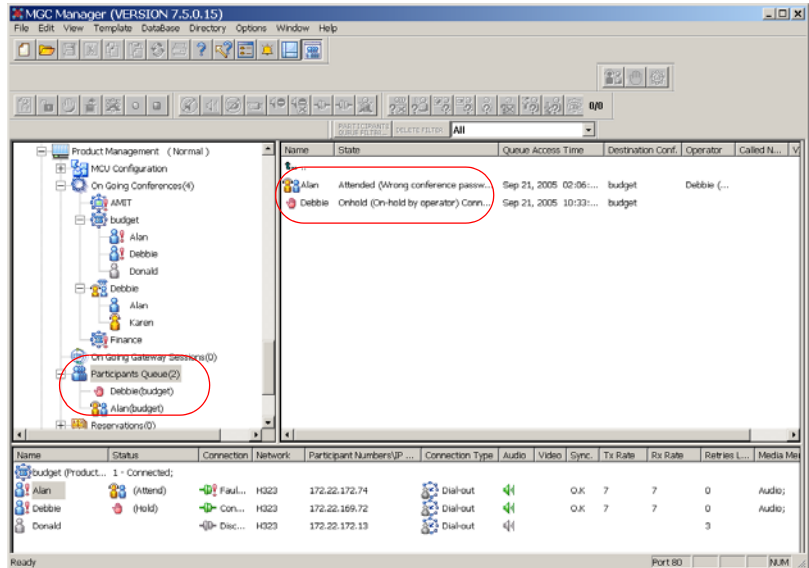

- *Participants Queue window*

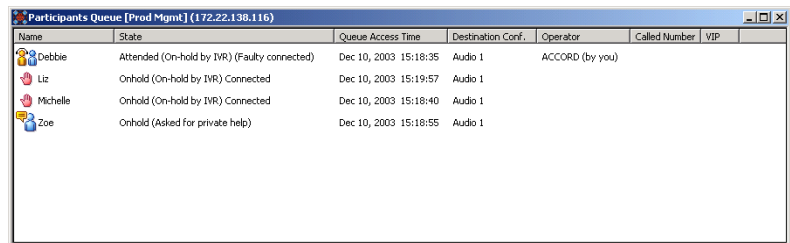

Performing Operations using the Right-Click Menu

Moving a Participant to the Operator Conference

To move a participant to the Operator conference from the On Going Conferences list:

1. In the *Browser*, *Status*, or *Monitor* panes, display the list of participants in the On Going Conference.
2. Right-click the icon of the participant to be moved to the Operator conference, and then click **Attend**.



The participant is moved to the Operator conference while his/her icon remains in the conference list and in the *Participants Queue* list. An exclamation point appears next to the *Participant* icon in the *Name* column of all panes and in the conference tree.

In addition, the *Attended* icon  is displayed in the *Status* column of the Participants List in the *Monitor* and *Status* panes.

To move a participant to the Operator conference from the Participants Queue tree or Participants Queue window:

1. Display the list of participants in the Participants Queue in the *Browser* or *Status* pane, or in the *Participants Queue* window.
2. Right-click the icon of the participant to be moved to the Operator conference, and then click **Attend** or **Attend with Details**.

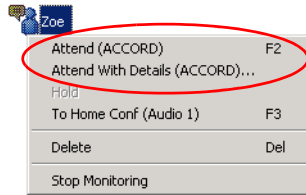

If you click **Attend**, the participant is moved to the Operator conference and still appears in the Participants Queue.

If you click **Attend with Details**, the participant is moved to the Operator conference and still appears in the Participants Queue. In addition, the *Attended Participant* window opens. For more details, see “**The Attended Participants Dialog Box**” on page 7-21.

The participant is moved to the Operator conference while his/her icon remains in the conference list and in the Participants Queue list. An Exclamation point appears next to the *Participant* icon in the *Name* column of all panes and in the conference tree.



In addition, the *Attended* icon is displayed in the *Status* column of the Participants Queue in the *Monitor* and *Status* panes.

Moving a Participant to the Home Conference

To move participants to their Home conferences from the Operator conference list:

1. In the *Browser*, *Status*, or *Monitor* panes, display the list of participants in the Operator conference.
2. Use one of the following options:
 - a. **Using the Move option in the right-click menu:**
 - Right-click the icon of the attended participant to be moved to the Home conference, and then click **Move**.

A list of conferences appears.

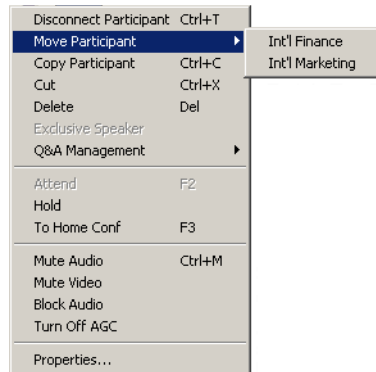

— Click the name of the Home Conference to which to move the participant.

b. Using the To Home Conference option in the right-click menu:

Right-click the icon of the attended participant and then click **To Home Conf.**



The participant connects to the Home conference and is removed from the Participants Queue and/or the Operator conference. The *Attended* or *Hold* icon in the *Status* column of the *Monitor* and *Status* panes disappears.

To move a participant to his/her Home conference from the Participants Queue tree or the Participants Queue window:



Standard MS-Windows multiple selection techniques can be used in the following procedure.

1. Display the list of participants in the Participants Queue in the *Browser* or *Status* pane, or in the *Participants Queue* window.
2. Move the participant to the Home conference using one of the following options:

a. Using the Move option in the right-click menu:

- Right-click the icon of the participant to be moved to the Home conference, and then click **Move**.

A list of conferences appears.

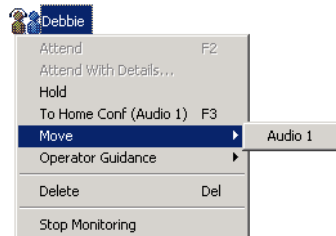

- Click the name of the Home Conference to which to move the participant.

b. Using the To Home Conference option in the right-click menu:

Right-click the icon of the participant to be moved to the Home conference, and then click **To Home Conf**.

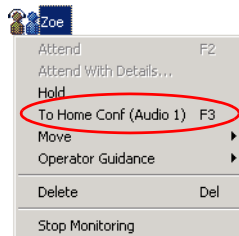

The participant connects to the Home conference and is removed from the Participants Queue and/or the Operator conference. The *Attended* or *Hold* icon in the *Status* column of the *Monitor* and *Status* panes disappears.

Placing a Participant On Hold

A participant can be placed on hold while in the Participants Queue or when participating in an Operator conference.

Usually, the participant waiting in the Entry Queue or Participants Queue is first assisted by the operator and is then placed on hold until all the participants pertaining to the same conference are assisted and placed on hold. Once all the participants are on hold, they can all be connected at the same time (in one operation) to the conference.

In addition, a participant in an On Going Conference can be placed on hold when he/she is to be excluded from the conference for a short period. To do so, you have to first move the participant from the conference to the Operator conference and then place him/her on hold.

To place a participant on Hold in the Operator conference:



Standard MS-Windows multiple selection techniques can be used in the following procedure.

1. In the *Browser*, *Status*, or *Monitor* pane, display the list of participants in the Operator conference.
2. Right-click the icon of the participant to be placed on hold, and then click **Hold**.

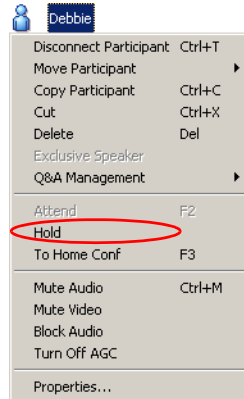

The *Participant* icon changes to *Hold* in the *Status* column of the Home conference participants list in the *Monitor* and *Status* panes, and in the Participants Queue.

To place a participant on hold in the Participants Queue tree or the Participants Queue window:

1. Display the list of participants in the Participants Queue in the *Browser* or *Status* pane, or in the *Participants Queue* window.
2. Right-click the icon of the participant to be placed on hold, and then click **Hold**.

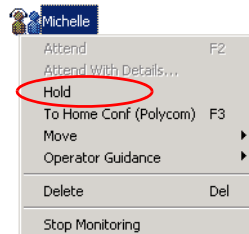

The *Participant* icon changes to *Hold* in the *Status* column of the Home conference participants list in the *Monitor* and *Status* panes, and in the Participants Queue.

Performing Operations Using the Participants Queue Toolbar

You can perform operations using the Participants Queue toolbar from the following panes and lists:

- *Browser, Status, and Monitor panes, On Going Conferences list*
- *Browser and Status panes, Participants Queue list*
- *Participants Queue window*

To move a participant or place him/her on hold using the Participants Queue toolbar:



Standard MS-Windows multiple selection techniques can be used in the following procedure.

1. Select the participant's icon.
2. Click the relevant button in the Participants Queue toolbar, as follows:

Table 7-7: Participants Queue Toolbar Buttons

Button	Operation
	To move the participant to the Operator conference.
	To place the attended participant on Hold.
	To move the participant to the Home (destination) conference.

For further details on the individual operations refer to the explanations in the section “Performing Operations using the Right-Click Menu” on page 7-36.

Performing Operations Using Shortcut Keys



Standard MS-Windows multiple selection techniques can be used in the following procedure.

You can perform operations using shortcut keys from the following panes and lists:

- *Browser, Status, and Monitor* panes, *On Going Conferences* list
- *Browser and Status* panes, *Participants Queue* list
- *Participants Queue* window

To move a participant or place him/her on hold using shortcut keys:

1. Select the icon of the participant to be operated on.
2. Use the appropriate shortcut key, as follows:

Table 7-8: Shortcut Keys

Default Shortcut Key	Operation
<F2>	To move the participant to the Operator conference.
<F3>	To place the attended participant on Hold.
<F4>	To move the participant to the Home (destination) conference.

For further details on the individual operations refer to the explanations in the section “Performing Operations using the Right-Click Menu” on page 7-36.

Moving a Participant Interactively



Standard MS-Windows multiple selection techniques can be used in the following procedure.

You can drag and drop a participant to the Operator or Home conference from the following panes and lists:

- *Browser*, *Status*, and *Monitor* pane, Operator conference list
- *Browser* and *Status* pane, *Participants Queue* list
- *Participants Queue* window

To drag and drop a participant to the Operator conference:

1. Expand the On Going Conferences list in the *Browser* pane, to display the *Operator Conference* icon.
2. Drag the icon of the participant to the *Browser* pane and drop it on the *Operator Conference* icon.

To drag and drop a participant to the Home conference:

1. Expand the On Going Conferences list in the *Browser* pane, to display the *Home Conference* icon.
2. Drag the icon of the participant to the *Browser* pane and drop it on the *Home Conference* icon.

Moving Multiple Participants to the Home Conference

When several participants are placed on hold, they can all be selected (using standard Windows multi-selection options), and then moved to the appropriate conference together.

To move several participants who are on hold to the Home Conference:

1. List the participants who are on hold in the appropriate conference or in the *Participants Queue* tree, or the *Participants Queue* window.
2. Select the participants that are on hold.

3. Move the selected participants to their destination conferences, using one of the following methods:
 - a. **Using the To Home Conference option in the right-click menu:**
 - Right-click the icon of one of the highlighted participants, and then click **To Home Conf.**
 - b. **Using the Move option in the right-click menu:**
 - Right-click the icon of one of the highlighted participants, and then click **Move**.
 - A list of conferences appears.
 - Click the name of the conference to which to move the participants.
 - c. **Using the Participants Queue toolbar:**
 - Click the icon of one of the highlighted participants.
 - Click the **To Home Conf.**  button on the Participants Queue toolbar.
 - d. **Dragging and Dropping the Participant icon:**
 - Expand the On Going Conferences list in the *Browser* pane, to display the *Home Conference* icon.
 - Drag the icons of the participants to the *Browser* pane and drop them on the *Home Conference* icon.

The selected participants are immediately connected to the conference.

Recording

The Polycom *ReadiRecorder* is fully integrated with Polycom's MGC Manager application and can be accessed by means of the Polycom web interfaces - the WebCommander application, and the product's own Web site.

As a flexible, multi-conference, multi-network solution, the Polycom *ReadiRecorder* system enables recording and playback of conferences over ISDN/PSTN or IP networks. With Polycom *ReadiRecorder* you can record audio-only conferences and the audio part of unified (audio and video) conferences, and monitor and manage on going recording sessions and playbacks using its management tools. You can store, play and download recordings, and manage the recordings database.

The MGC Manager application is used to configure and monitor the *ReadiRecorder*, to manage recording and playback services, configure recording options for conferences, and manage the recording process.

You can also enable the conference recordings using the Polycom WebCommander application, and manage the *ReadiRecorder* recordings through the *ReadiRecorder* Web site. In the WebCommander application, you can configure recording options for conferences and manage the recording process.

Using the *ReadiRecorder* Web site, you can manage the stored files, play the recordings or download them to your local computer. On an administrative level you can also register and manage *ReadiRecorder* users.

The recording system can be installed at the same site with the conferencing MCU or at a remote site. Several MCUs can share the same recording system.

Figure 8-1 shows the system components, connections and data flow of the system.

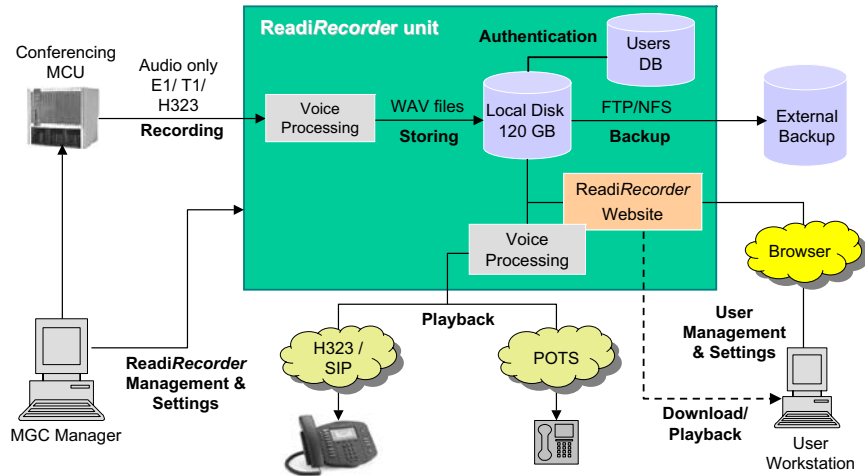

Figure 8-1: ReadRecorder System and Connectivity

System Setup

Recording of conferences is performed over a PSTN/ISDN or an IP (H.323) connection established between the conferencing MCU and the ReadRecorder. The Polycom ReadRecorder handles any combination of recordings or playbacks on up to 48 ports in a mixed IP or PSTN/ISDN network. Conferences are recorded by the ReadRecorder over a dial-out connection from the conference to the recording system. This connection is called Recording Link. Recording Links are defined on the conferencing MCU, in the MGC Manager application.

To connect conferences to the recording system, the Recording Link uses the dialing number which was defined in the ReadRecorder's Recording Service. To access the stored recordings of conferences, the end-user dials the number which was defined in the ReadRecorder's Playback Service. Recording and Playback Services are configured on the ReadRecorder in the MGC Manager application.

An additional component required for the Recording and Playback Services is the *IVR Message Service*. IVR must be configured before the *Recording and Playback Services* definition since it includes the DTMF codes and messages, such as *pause* or *resume recordings* which are required for controlling the

recording and playback processes by the conference participants. For the setup workflow, see “Recording System Setup Procedures” on page 8-4.

Recording

Once the Recording Links are defined on the conferencing MCU, recordings can be started and paused or terminated when needed, by the MGC Manager operator or by the conference chairperson by means of the WebCommander application or over the phone, using DTMF codes. A recording session can be started automatically or at the request of the conference chairperson or the system operator. The completed recordings are stored on the recording system's hard drive and can be accessed from the Polycom *ReadiRecorder* Web site for playbacks, downloads and management. System operators can selectively record specific conferences, or provide the conference chairperson with the ability to record on demand.

Processing

In the *ReadiRecorder* unit, the recording is processed according to standard voice processing methods and is then saved as a file and stored on the local disk. Optionally, recordings can also be backed up to an external disk. Backup as well as deletion policies can be defined for the system. Users can then identify and select the stored recordings for playback or download, according to the known session ID or according to the name of the user who initiated the recording and is its owner.

Monitoring and Management

Monitoring and management of the recording process is done in the MGC Manager application. The system administrator can monitor all on going recordings and playbacks on each *ReadiRecorder*, the status of used and available port resources and CDRs (Call Detail Records) that list information about events and conferences in which recording or playback services are involved.

In the Web site, the administrator can modify user permissions, add or delete users, download and delete recordings, and can configure the maximum allocated disk space for recordings. The administrator usually registers the Web site users, but, depending on the Web site settings, non-administrative users can also register themselves. Registered users with appropriate permissions can login to the Web site where they can view, play, download or delete their own recordings.

In WebCommander, users can observe the status of the recording link in a conference.

Download and Playback

Users can easily download recordings to a local PC or listen to them from a telephone or on the Web. To access the files stored on the *ReadiRecorder*, the user must submit the *Recording ID* (via DTMF) or login to the Web site and select the recording to listen to or download. To download a file without login, the user must open the Home Page and submit the *Recording ID*.

Recording System Setup Procedures

For the recording system to function, you must configure both the recorder and the conferencing MCU with the required components.

ReadiRecorder Setup

Installing and configuring the *ReadiRecorder* is performed in the MGC Manager application, using similar procedures as for installing and configuring an MCU.

Assuming that the MGC Manager is already installed on your workstation, you must perform the following tasks to set up the *ReadiRecorder* side:

1. Install the unit, power it up and perform the required IP configuration.
2. Start the MGC Manager application and connect to the conferencing MCUs.
3. Add the *ReadiRecorder* to the MCU network using its configured IP and connect it to the MCU network.
4. (Optional) Obtain an SSL certificate for the *ReadiRecorder*.
5. Configure the required PSTN/ISDN or IP Network Services for the unit.
6. Configure the IVR (Interactive Voice Response) Services and messages for managing recordings and playbacks.
7. Set up Recording and Playback Services for recording related prompts and assign the dialing numbers.
8. (Optional) Configure the recording system settings: allocate disk space for each user's recordings, define database use and backup and delete policies.
9. (Optional) Set up system.cfg flags related to recording.
10. Register users in the *ReadiRecorder* Web site or link to an external users database to enable them to play and download the conference recordings.

Conferencing MCU Setup

Assuming that the MGC Manager is already installed on your workstation, perform the following tasks to set up the MCU for recording:

1. Configure the Recording Link between the conference and the recorder.
2. Configure the recording-related IVR Message Services to be used during recording.
3. Enable and specify the recording functions for conferences.

To enable the Polycom *ReadiRecorder* to perform, you must configure the following components:

- *First entry IP configuration* – (IP Address, Net Mask and Gatekeeper) adjusts the default IP of the *ReadiRecorder* unit.
- *ReadiRecorder definition in the network* – adds the unit to MCUs network (in the MGC Manager application).
- *SSL certificate* – (Optional) secures the connection between the *ReadiRecorder* and the MGC Manager and the Web site.
- *Network Services* – (PSTN/ISDN or IP) define the parameters of the networks connected to the *ReadiRecorder*.
- *IVR Message Services* – sets of voice prompts or messages that allow support of multiple languages and user-specific voice prompts.

The message service is activated when recording is initiated, stopped or paused, or when listening to a playback.

- *Recording and Playback Services* – define the dial-in numbers and IVR Message Services used for recording and playback connections.
- *Recording System Settings* – (Optional, if modifications of the default settings are required for certain functions) global settings for the recording system, such as disk space allocation for users and recordings, backup and deletion policies, and database usage.
- *Recording-related system.cfg flags* – (Optional) recording related system flags.

When these components are configured, you will be able to record the recording-enabled conferences running on your MCU and to monitor the recordings and playbacks on the *ReadiRecorder*.



ReadiRecorder software includes a default IVR Service.

The following illustration describes the *ReadiRecorder* configuration:

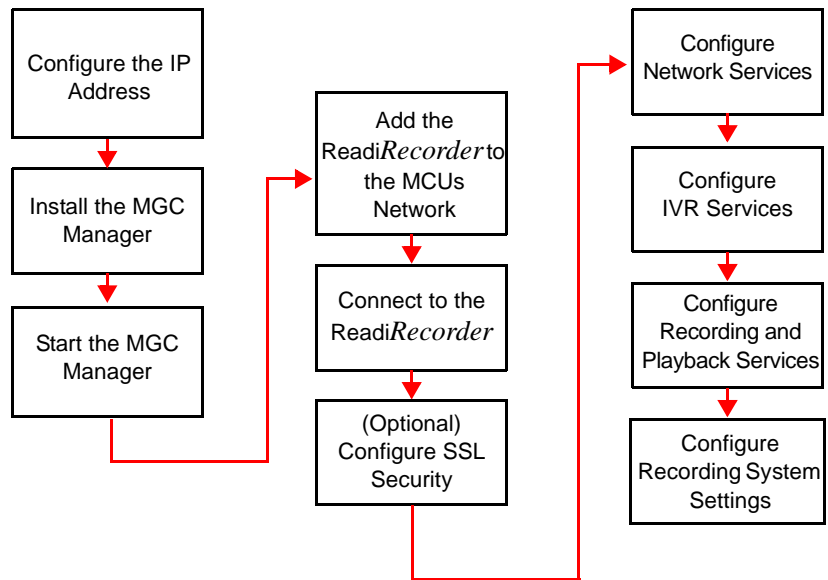

- Installing the MGC Manager application is mandatory in the workflow only in cases when you are:
 - installing the application for the first time
 - updating the software version

For detailed information about installing MGC Manager, connecting to the MGC unit, and using the application’s main window, menus and toolbar buttons, refer to the MGC Manager User’s Guide, Volume I, Chapter 3, “MGC Manager Basics.” For information about how to configure the *ReadiRecorder* components, see the *ReadiRecorder* Getting Started Guide.

Setting up Recording for Conferences

This description of how to set up the recording functions for conferences explains only the procedures relevant to the *ReadiRecorder*. For the in-depth description of the entire conference setup procedure, refer to MGC Manager User's Guide Volume I, Chapter 4.

Conference definition is performed in the conferencing MCU, using the MGC Manager. Recording definition is identical for all types of conferences. It is also the same for unified (audio and video) and for audio-only conferences.

To make recording possible, you must set up the following components on the conferencing MCU:

- *Recording Link* – define the connection between the conference and the *ReadiRecorder*. For details, see “Defining a Recording Link” on page 8-7.
- *Recording-enabled IVR Service* – the recording DTMF codes and messages must be set in the IVR Service to enable recording by the conference chairperson and to play the voice messages indicating the recording status. For details, see “Defining Recording Functions in IVR Service” on page 8-11.
- Configure the relevant *system.cfg* flags. For more information about configuring the *system.cfg* files, see “Modifying System.cfg” on page 8-22.



Since only IVR-enabled conferences can be recorded, when defining a new On Going Conference or Reservation, you must include a recording-enabled IVR Service.

Defining a Recording Link

A Recording Link is the connection between the conferencing MCU and the *ReadiRecorder*. You can configure different Recording Links for specific connection types (ISDN or IP) and then use them repeatedly to record conferences.

You need the following information to complete the link definition:

- *Network Service* – the Prefix of the IP Network Service defined for the *ReadiRecorder*, see the *ReadiRecorder* Getting Started Guide, “Configuring Network Services”, page 3-18.

- *Recording Service* – the name of the *Recording Service* you defined for the *ReadiRecorder* (for IP Recording Links), and the dial-in number assigned to the Recording Service (for ISDN Recording Links), see the *ReadiRecorder Getting Started Guide*, “Defining a New Recording & Playback Service”, page 3-38.

To define a new recording link:

1. Expand the *MCU Configuration*. Right-click the *Recording Links* icon and then click **New Recording Link**.



The *Recording Link* dialog box opens.

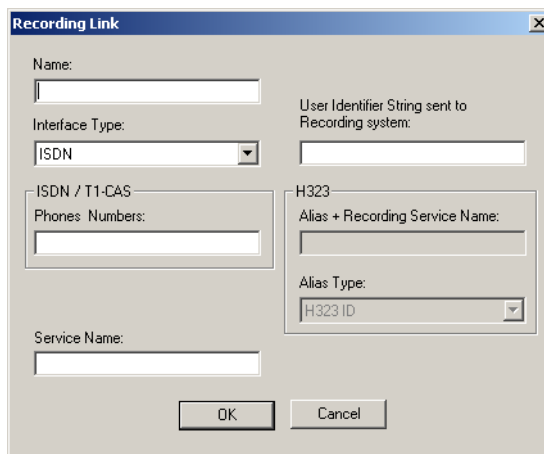

2. Configure the following parameters:

Table 8-1: Recording Link Properties

Field/Option	Description
<i>Name</i>	Enter the name for the Recording Link.
<i>Interface Type</i>	Select the type of connection between the REDIRecorder and the conferencing unit: <ul style="list-style-type: none"> • ISDN • T1-CAS • H.323
<i>User Identifier String sent to the Recording System</i>	The identifier that identifies the user. This number is checked against the numbers registered in REDIRecorder database. Only registered identifier strings are allowed to initiate recording. This string will be used as the user identification number in the REDIRecorder Web site. Enter digits (in this case all the recordings using this link will be assigned this number), or enter one of the following codes: n – The recording will be assigned the recorded conference Numeric ID c – The recording will be assigned the chairperson password of the recorded conference e – The recording will be assigned the password of the recorded conference b – The recording will be assigned the conference billing code Note: The string must be followed by a <i>Pound</i> key (#), to signal the end of transmission.
<i>ISDN-T1CAS Phone Numbers</i>	If you have selected an ISDN or T1-CAS connection, enter the phone number to be dialed to connect to the REDIRecorder. This should be one of the dial-in numbers assigned to the Recording Service in the REDIRecorder.

Table 8-1: Recording Link Properties (Continued)

Field/Option	Description
H.323	<p>If you selected an H.323 link to the REDIRecorder, enter the required parameters:</p> <ul style="list-style-type: none"> • Alias and Recording Service Name - The H.323 Network Service Prefix defined in the REDIRecorder and the Recording Service Name. • Alias Type - Select the type of alias from list: <ul style="list-style-type: none"> — H323 ID — E164 — URL ID — Email ID — Transport ID — Party Number <p>It is recommended to use H323 ID or E164 as the alias type.</p>
Service Name	<p>Enter the name of the Network Service to be used by the conferencing MCU when dialing to the REDIRecorder. If left blank, the default Network Service (according to the selected network connection) will be used.</p>

3. Click **OK**.
The link you defined is listed in the *MCU Configuration* under the *Recording Links* icon. You can now assign the link to the conferences that you want to record.



- You can modify the parameters of a link, but not its name. To modify a link, right-click its icon or name and click **Properties**.
- If you defined several links, you can select one of them as the default. Right-click the recording link's icon and click **Set As Default**. The name of default link is bolded.

Defining Recording Functions in IVR Service

For the conferencing MCU, you need to define an IVR Message Service with activated recording messages and DTMF codes.



This step is required only if you are not using the default IVR Service or if your current IVR Service does not include the recording messages.

For a full description of the definition of new IVR Services in MGC Manager, refer to the MGC Manager User's Guide Volume II, Chapter 2. In this context only the procedures relevant to the *ReadiRecorder* are described.

To define recording functions for an IVR Service:

1. When defining a new IVR Service in the *IVR Service Properties* wizard, open the **General** dialog box and scroll down the list of messages to the recording messages.
2. Select the *Recording In Progress* message and from the list select the appropriate message file: **rcrdconf.aca**.
3. Select the *Recording Failed* message and from the list select the appropriate message file: **rcrdfail.aca**.

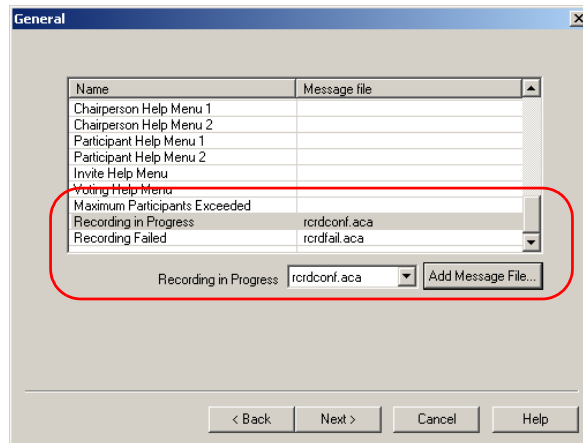

4. In the *DTMF Codes* dialog box, scroll down the list of messages to the the three recording messages:
 - Start Recording
 - Stop Recording
 - Pause Recording
5. Optional. To change the default settings for a recording DTMF, select the message from the *Name* column and modify its **DTMF Code** or **Permission** in the boxes below the table.

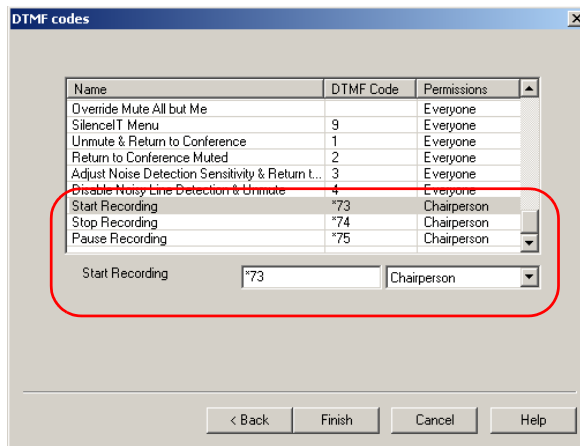

6. Click **Finish**.
The IVR Service you defined is listed in the *MCU Configuration* under the *IVR Msg Services* icon. You can now apply the service to the conferences you want to record.



- You can modify the parameters of a service, but not its name. To modify a message service, right-click its icon or name and click **Properties**.
- If you defined several services, you can select one of them as the default. Right-click the service icon and click **Set As Default**. The name of default service is bolded.

Enabling Recording for a Conference

This procedure is identical for all types of conferences.

To enable recording for a conference:

1. In the *Conference Properties - Settings* dialog box, in the *Message Service Type* box, select **IVR**.
2. In the *Message Service Name* list, select a recording-enabled IVR Service.

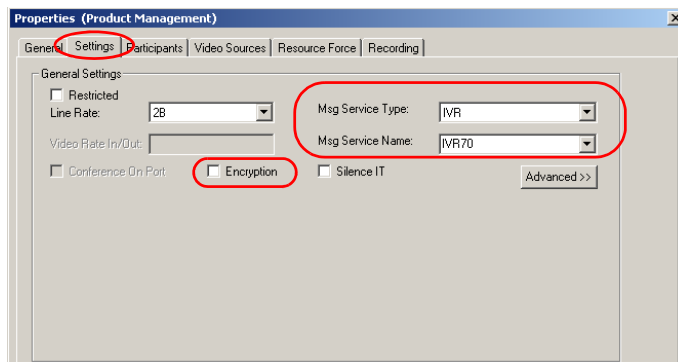

3. Leave the *Encryption* option disabled (clear check box) at the conference level.



Recording cannot be done on an encrypted connection. Therefore, to record encrypted conferences, encryption must be set at the participant level, and all participants except the Recording Link can be encrypted.

4. Click the **Recording** tab.

The *Conference Properties - Recording* dialog box opens.

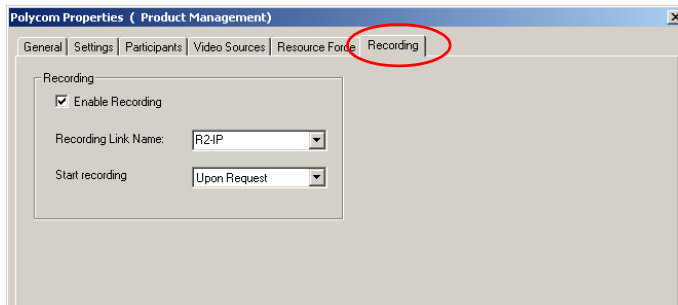

5. In the *Recording* pane:
 - a. Select the **Enable Recording** option to enable recording.
 - b. In the *Recording Link Name* list, select the required link according to the conference Network connections. For an IP-only conference, use an IP Recording Link. For ISDN or a mixed network conference, select either an ISDN or an IP Recording Link.
 - c. In the *Start Recording* list, specify when to start recording:
 - **Immediately** - when the first participant connects to the conference (automatic)
 - **Upon Request** - when the operator or chairperson initiates recording (manual)

If you select the manual option, the operator will initiate recording in the MGC Manager (or in the WebCommander) application using the *Start Recording*  button on the toolbar, while the conference chairperson will initiate recording by entering the appropriate DTMF key on the phone.

6. Complete the conference definition and click **OK**.

Recording with MCU Version 7.05

In a configuration involving MCU v.6.11 or later and MGC Manager v.6 or later, you can record conferences with *ReadiRecorder*, using the following procedure.

Even without the special Recording port or Link available in MGC version 7.0 and 7.1, you can set up recording in MGC version 6 or later for a conference by means of a special participant that acts as the recording port. This participant is then included in a conference to be recorded, and once it connects to the *ReadiRecorder*, the recording starts.

This type of definition is set in the *Participant Properties* dialog box where the link is defined as a dial-up participant for an IP or an ISDN connection.

To enable recording:

1. When defining a new On Going conference or reservation, click the *Participants* tab.
The *Conference Properties- Participants* dialog box opens.
2. Click the **New** button to define a new participant.
The *Participants Properties- Identification* dialog box opens.
In the *Participant Properties - Identification* dialog box, these settings are required for a recording link:
 - *ISDN* – For a participant with ISDN (PSTN or T1-CAS) connection, the definition will include the dial-in *Participant Number* to access *ReadiRecorder*.
 - *IP* – For a participant with IP connection, the definition will include the IP Network Service Prefix and name of the IP *Recording Service* to be used, that was set up in *ReadiRecorder*.
 - *Extension Identifier String* – For both types of participant, the definition will include the participant's name with the specific extension, in the format: **party name[ext:(user identifier string)#]**.
The User identifier string can be a string of numbers (user ID) or one of the following codes:
 - n** – The recording will be assigned the recorded conference Numeric ID
 - c** – The recording will be assigned the chairperson password of the recorded conference

- e - The recording will be assigned the chairperson password of the recorded conference
 - b – The recording will be assigned the conference billing code
3. Click the **Advanced** tab.
In the *Participant Properties - Advanced* dialog box, these settings are required:
 - *Recording* – For both types of participant, recording will be enabled as **Dial-up**.
 4. Complete the participant definition and click **OK**.
The defined participant is now saved in the User Template database and listed as the conference participant.
 5. In the *Conference Properties – Participants* dialog box, select the recording port/link participant in the Pre-defined Participants list and click the >> button to move the participant to the *Conference Participants* list.
The participant is now included in the conference.
 6. Complete the conference definition and click **OK**.
The appropriate icon is displayed in the list of conference participant.

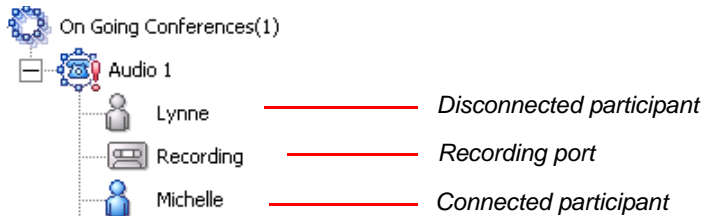

When the recording port is connected to the conference, the *Recording*

icon  changes (from gray to blue) to indicate the active state.



When working with conferencing MCU Version 6.11 or higher, the flag “preferred secured port” should be erased from the system.cfg to prevent an SSL error.

Recording and Playback Using Prairie Systems

Prairie Systems provide audio recording and playback services for conferencing, that you can use with the MGC. To connect to the Prairie Systems recording facility and make recordings, a special *Recording Port* participant must be defined. The Recording Port is then added to the conference during the conference definition when making a list of participants - in the *Conference Properties - Participants* dialog box. In addition, the recording function must be enabled in the *Conference Properties - Recording* dialog box.

Conference recording using the Prairie system can be activated using:

- MGC Manager application
- DTMF-enabled phone

Conferences can be recorded by an operator using the *Blast Dial-out* feature in MGC Manager, or by a chairperson - from a DTMF-enabled phone. To record a conference, a chairperson must have access to a DTMF-enabled phone and to use the appropriate DTMF code (the default code to start recording is *25). The chairperson can start, stop and record sections of the conference as needed, and, in addition, has the ability to record and play back conversations.



To implement recording, customers must obtain an account with Prairie Systems. For details, see <http://www.prairiesys.com/PSI/01-0300.html>. In the U.S., call 1-800-888-3151.

Polycom customers who require recording services need to obtain the following information:

- **From Prairie Systems:**
 - Account prefix number
 - Dial-in numbers of the Prairie recording system and playback system
- **From the Conferencing Service:**
 - A unique account number for each conference

A participant functioning as a recording port activates the Prairie recording system. The following information is required to define a recording port:

- The name of the Network Service defined as a Recording Link
- IVR Message Service DTMF “Dial-out” code to be used by the chairperson who initiates the dial-out call to activate the Prairie system
- Telephone (dial-out) number - to access the Prairie Systems account
- Conference account prefix issued by Prairie Systems
- Conference account number issued by the conferencing service provider

Defining a Recording Port Participant

To define a dial-out recording port:

1. Define a new ISDN Participant.
2. In the *Name* field, enter a string in the following format: (Optional digit field; 0...9), (Free text; Rec), ([Extension; EXT), (p), (Account Prefix; 2234), (p), (Account ID; 9876543), (p), (Pound keys; ##]). For example, **9Rec[EXT:p2234p9876543p##]**.

Each section of the string is explained below:

- *0...9* - Optional digit field. Any digit between 0 and 9. That identifies the participant. This digit is used as part of the DTMF code to initiate the blast dial-out sequence. For example, when a chairperson enters ***259**, where ***25** is the DTMF code for blast dial out, and **9** is the number that identifies a recording port participant. This digit must be unique, and no other participant can have an identical number.
- *Free text* – Optional text field, may be omitted
- *Brackets []* – Brackets indicating a dial string. Brackets are context sensitive, and only this type [] of format is to be used

- *Extension text prefix* (Ext;, ext;, EXT; are permitted) - Code indicating that a string consisting of a series of digits are to be used during dial-up and connection to the Prairie system.

The participant's name, Prairie's account prefix and conference recording ID

Prairie's recording phone number

- *p* - Induces a pause of 1 second before transmitting the next digit or DTMF code. There is no limit to the number of p's in a dial string and can be located anywhere in the dial-up string.
- *Account prefix* - Account prefix consisting of a series of digits that are provided by Prairie.
- *Conference account ID* - unique account ID for each conference. The conference account ID can consist of one of these options:
 - *a* – series of numbers
 - *n* – indicating the Numeric conference ID
 - *l* – indicating the conference Chairperson password
 - *b* – indicating the conference billing code
- *##* – Pound keys, a suffix added to the string, required by the Prairie system, signaling end of transmission

3. In the *Connection Type* field, select **Dial-out**.
4. In the *Participant Phone Numbers* field enter Prairie's phone number.
5. In the *Interface Type* field, make sure that **ISDN** is selected.
6. Select the *Audio Only* check box.
7. Click the **Advanced** tab.
The *Participant Properties - Advanced* dialog box opens.
8. In the *Recording* field, select **Dial-up**.

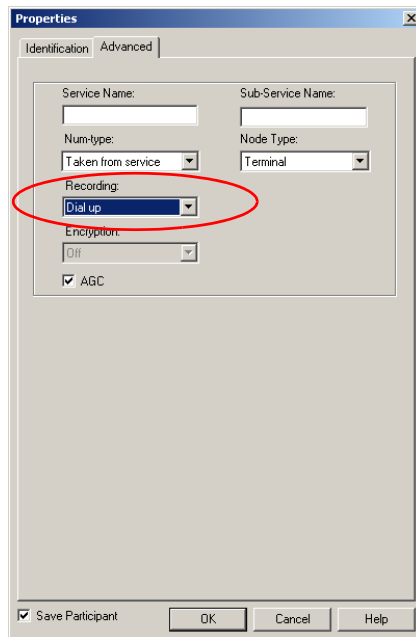

9. Click OK to complete the participant definition.
The participant (Recording Port) is added to the list of participants for the conference, with an icon indicating that it is a recording port.

Recording and Playback

To record a conference:

- When the conference starts, activate the recording function by pressing the DTMF code representing blast dial-out and the participant (recording port) ID at any time during the conference. For example, ***259** where ***25**

is the DTMF code for a dial-out, and **9** represents the first digit assigned to the participant in the *Name field* in the *Properties - Identification* dialog box.

When recording is initiated for a recording-enabled conference, the MCU calls *Prairie Systems* using the parameters defined for the participant (port), thus enabling the service.

When *Prairie Systems* begins recording the conference, it first plays a voice message announcing that the conference is being recorded.

To stop recording:

- To stop recording, use one of the following methods:
 - enter the DTMF code ***25#**
 - terminate the conference from the conference.
 - disconnect the recording port.

When recording is terminated, the chairperson can re-activate a *Prairie* recording session using the procedure described above. However:

- Re-activating the recording results in a new recording ID issued by *Prairie*.
- It is not possible to play back several recordings of a conference at the same time.

To initiate a playback of a *Prairie* recording:

1. The conference chairperson accesses the *Prairie Systems* website and enters the conference account number and the conference access password /chairperson password (depending on the current configuration of access requirements).
2. The *Prairie Systems* web site displays confirmation data consisting of the unique Conference Recording ID, recording date and time, and a conference description. The confirmation ID consists of the conference's account number, for example 9876543, and an additional 3 digit sequence, for example 9876543**001**.
The Conference Recording ID number is required to play a conference recording.
3. The chairperson must retrieve the Conference Recording ID, for example 9876543001, and dial the *Prairie's* playback dial-in number using the appropriate DTMF code. The playback of the recorded session occurs directly between the endpoint and *Prairie's* system.

Modifying System.cfg

This following system.cfg flags are relevant to the *ReadiRecorder* and should be modified when required.



Modifying the system.cfg requires that system reset is performed. Do not reset the system unless absolutely necessary.

To modify the *ReadiRecorder* system.cfg:

- To access the system.cfg window, right-click the *ReadiRecorder* icon, click *Recording System Utils* and from the submenu, select **Edit “system.cfg”**.

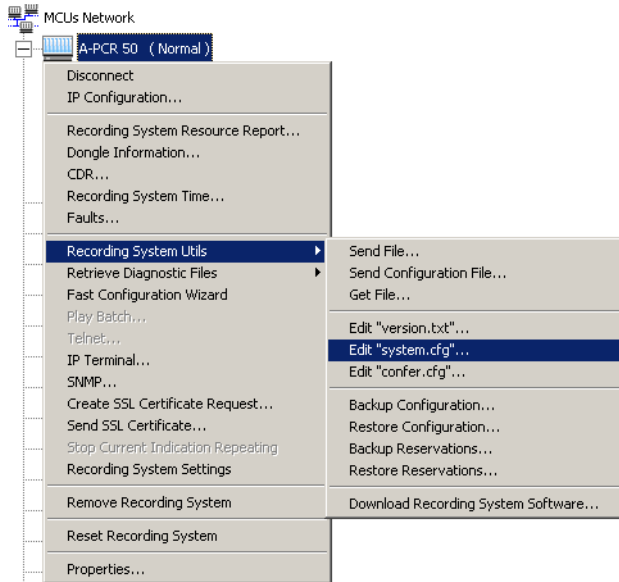

The *SysConfig [system.cfg]* dialog box opens.

The following table lists the system.cfg flags you can check and modify.

Table 8-2: *ReadiRecorder* system.cfg Flags

Section / Default Flags and Values	Required Value	Description
Audio Plus		
SINGLE_PARTY_HEARS_MUSIC = NO	NO	No need for background music.
AUDIO_PLUS_CM_MSG_32 = 64	64	Affects the <i>ReadiRecorder's</i> <i>IVR Messages Status</i> report. The default is the maximum number of IVR messages that can be downloaded for a given group (in this case 64 messages of 32-second duration).
CDR		
CDR = YES	YES	Enables viewing the CDRs list for the <i>ReadiRecorder</i> . When disabled, the CDRs do not include records that were written to the <i>ReadiRecorder</i> disk.
External DB		
ENABLE_EXTERNAL_DB_ACCESS = NO	YES	Allows the definition of an external database for the Web site user authentication. Note: If you enable this function, set the other flags in this section. For more information, see the External DB Tools documentation.

Table 8-2: ReadiRecorder system.cfg Flags (Continued)

Section / Default Flags and Values	Required Value	Description
General		
PREFERRED_PORT = 80	80	Default unsecured port.
PREFERRED_SECURED_PORT = 443	443	The default secured port required for SSL certified connections. This flag is added manually, when obtaining the SSL certificate.
SECURED_PORT_MANDATORY_FOR_API = NO	NO	Enables choosing a secured or an unsecured port for the recorder.
	YES	Required if the recorder is to use <i>only</i> the secured port and Secured mode.
SECURED_PORT_MANDATORY_FOR_FILE = NO	YES	Required for securing the recorder's Web site.
Recording		
RECORDING_SYSTEM = YES	YES	Activates the recording functions. Required for recording-enabled conferences.
RECORDING_SKIP_TIME=180	-	May be user defined. Measured in seconds.
RECORDING_SKIP_TO_END_TIME = 30	-	May be user defined. Measured in seconds.

For more information on system configuration, refer to the MGC Manager Administrator's Guide.

Conferencing MCU system.cfg flags

The following table lists the system.cfg flags you can check and modify:

Section / Default Flags and Values	Required Value	Description
Audio Plus		
SINGLE_PARTY_HEARS_MUSIC = NO	YES	If recording is configured to start <i>Immediately</i> , that is when the first party joins the conference, this party will not hear the IVR message "The recording has started". Enabling this flag allows the first party in an audio only conference to hear music while waiting for the next parties to join.
General		
ENABLE_DTMF_VIA_GW = YES	YES	Required in a special playback service configuration which allows POTS playback via the conferencing MCU.

Appendix A: Glossary

This appendix lists the terms and abbreviations that relate to the MGC functionalities and technologies, and are commonly used in the MGC Manager documentation.

Abbreviation/ Term	Explanation
<i>AMI</i>	Alternate Mark Inversion. A T1 line coding format, inverting alternate ones.
<i>Asynchronous</i>	A transmission method used by dial up modems. Data is transmitted using a start bit at the beginning of a character and a stop bit at the end. The time interval between characters may be of varying lengths.
<i>ATM</i>	Asynchronous Transfer Mode. High speed (up to 155 Mbps) high bandwidth network that integrates voice, video and data. ATM provides connectivity to LANs, WANs, private networks and sub-networks. ATM supports applications requiring high transmission speeds, large transmission capacities, and bandwidth on demand.
<i>Audio Bridge</i>	Used to mix multiple audio inputs and to output composite audio to each of the endpoints connected to a conference.
<i>B8ZS</i>	Bipolar 8-Zero Substitution. A T1 line coding format substituting each group of eight consecutive zeros with an established pattern. See also T1 line.

Abbreviation/ Term	Explanation
<i>Bandwidth</i>	Defines the information carrying capacity of a channel. In analog systems, it is the difference between the highest frequency that a channel can carry and the lowest, measured in hertz. In digital systems, bandwidth is measured in bits per second. The larger a connection's bandwidth, the more data can be transmitted in a given amount of time, allowing for greater video resolution and more sites in a conference. See Line Rate.
BAS	Bitrate Allocation Signal. BAS codes are used to exchange information about capabilities and commands between devices at opposite ends of a digital video connection.
<i>B-Channel</i>	Bearer Channel. A channel in a span or in a group of spans, that carries audio-visual data. The ISDN circuit-switched bearer channel is capable of transmitting 64 Kbps of digitized information.
<i>Bonding</i>	Bandwidth ON Demand INterpolarity Group. A transmission protocol that aggregates two 64 Kbps B channels to function as one 128 Kbps channel. When using several BRI channels, Bonding means that only one D-channel serves all BRI channels, while the remaining D-channels are used for data transfer. See also: BRI.
<i>Bps, Kbps</i>	Bits and kilobytes per second; a unit of bandwidth, that is the amount of data that can flow during one second over a communications line (using a transmission medium). 1 Kbps=1000 Bps
<i>BRI</i>	Basic Rate Interface. A type of ISDN connection for transmitting data, consisting of 3 channels: two B-channels (each of 64 Kbps) and one D-channel (16 Kbps).
<i>Carrier</i>	A telephone or other company that provides telecommunication transmission services.
<i>Cascading Conference</i>	The use of two MCUs in a multipoint video conference, allowing for multipoint conferences with more than 12 video participants.

Abbreviation/ Term	Explanation
CAS	Channel Associated Signalling. An interface for Audio Only conference participants. See also T1-CAS.
<i>CIF, 4CIF, QCIF</i>	Common Intermediate Format, an optional part of the ITU-T H.261 and H.263 standards. CIF specifies 288 non-interlaced luminance lines, that contain 176 pixels. CIF can be sent at frame rates of 7.5, 10, 15, or 30 per second. When operating with CIF, the amount of data to transmit cannot exceed 256 K bits (where K equals 1024). The CIF video format has the capacity to transmit video images of 352x288 pixels at 36.45 Mbps and 30 frames per second. A 4CIF format has four times the capacity of CIF; QCIF has quarter the capacity of CIF.
<i>Circuit</i>	Another term for span; a T1 or E1 line.
<i>Codec</i>	<u>Coder-decoder</u> . A device that converts voice and video into digital code, and vice versa. Refers to the endpoint video camera and video board that are used for video conferencing.
<i>Conference</i>	Connection between two or more endpoints exchanging video and audio information. If only two endpoints are involved, a conference is called <i>point-to-point</i> and no MCU is required. If more than two endpoints are involved, it is called a <i>multipoint</i> conference, and an MCU (Multipoint Control Unit) is required as the management system. See also MCU.
<i>CSU</i>	Channel Service Unit. Customer-provided equipment that is used as an interface between a communication network and the data terminal.
<i>D-Channel</i>	The channel in a span or in a group of spans, which is used to transmit signaling information between the (public or private) switch and the MGC-100.
<i>DTMF</i>	Dual Tone Multi Frequency. A system of coded signals used by touch-tone telephones in which a specific sound, frequency or tone is assigned to each key so that the signal can be easily recognized by a computer. The codes enable data input and control of voice-processing systems. DTMF signals can pass through the entire connection to the destination device and therefore are used for remote control after the connection with the MCU is established.

Abbreviation/ Term	Explanation
<i>E1 line</i>	An 2 Mb digital switched line used in Europe.
<i>Endpoint</i>	An endpoint is any conferencing unit or participating/ connected party.
<i>G.711</i>	ITU-T audio algorithm, 64Kbps, 3.4 kHz.
<i>G.722</i>	ITU-T audio algorithm, 64Kbps, 7 kHz.
<i>G.728</i>	ITU-T audio algorithm, 16Kbps, 3.4 kHz.
<i>Gatekeeper</i>	A type of server that performs two main functions: translates LAN alias addresses of terminals and gateways to IP addresses and provides bandwidth management.
<i>H.221</i>	ITU-T standard that defines how to multiplex video, audio, control, and user data into one serial bit stream.
<i>H.230</i>	ITU-T standard that defines simple multipoint control systems procedures and describes network maintenance functions.
<i>H.231</i>	ITU-T standard that defines a set of MCU functions and operational requirements.
<i>H.242</i>	ITU-T standard that defines initiation of communications between systems and capabilities negotiation procedures.
<i>H.243</i>	ITU-T standard that defines initiation of communications between systems and capabilities negotiation procedures in multipoint conferences.
<i>H.261</i>	ITU-T standard that defines the Px64 video coding algorithm.
<i>H.263</i>	ITU-T standard that provides improved compression and quality of video images at a line rate lower than 384 Kbps. This standard is not supported by all codecs.
<i>H.264*</i>	A proprietary Polycom Video compression standard.
<i>H.264</i>	ITU-T standard that provides improved compression and quality of video images in lower line rate connections and is part of the Highest Common mechanism in Video Switching conferences.

Abbreviation/ Term	Explanation
<i>H.320</i>	ITU-T standard that defines how the H-series video conferencing recommendations work together.
<i>H.323</i>	ITU-T standard for audio, video and data communications across IP-based (LAN) networks, including the Internet.
<i>IMUX or Inverse Multiplexing</i>	A feature that allows high speed serial data streams to be divided into multiple of 56 or 64 Kbps for transmission over public digital switched networks (PSTN). At the remote end, all the channels are phase-aligned and synchronized to recreate the original data stream.
<i>IP</i>	Internet Protocol. The working protocol that forms the basis of the internet.
<i>ISDN</i>	Integrated Services Digital Network. A set of protocol and interface standards (voice, video and data) that comprise a telephone network. There are two types of ISDN lines: BRI and PRI.
<i>ITU-T Standard</i>	International Telecommunications Union, Telecommunication Standardization Sector (formerly CCITT). The international organization that produces official standards for telecommunications.
<i>LAN</i>	Local Area Network. A group of computers and other devices linked via a network's operating system.
<i>LDAP</i>	Lightweight Directory Access Protocol.
<i>Leased Line</i>	A dedicated PRI line supplied by the telephone company. See also PRI line.
<i>Line Rate</i>	The amount of bandwidth used by a communication device, measured in Kbps (kilobytes per second).
<i>MCU</i>	Multipoint Control Unit. Device which allows more than two sites to be connected in a video or audio conference.
<i>MPI</i>	Multi Protocol Interface. Supports connection to endpoints using communication protocols such as V.35 RS-449 and RS-530 over a serial connection.

Abbreviation/ Term	Explanation
<i>Network Service</i>	<p>A collection of spans from a fixed service provider. Network services can be any of the following types:</p> <ul style="list-style-type: none"> • Private Network • Public Utility, including: <ul style="list-style-type: none"> • Long distance service • Local service • PTT • PBX; local switchboard leased line
<i>Null modem cable</i>	<p>A serial cable designed to eliminate the need for communication equipment when two digital devices are directly connected to each other.</p>
<i>Port</i>	<p>One of 23 channels in a T1 PRI; one of 24 channels in a T1 leased line; or one of 30 channels in an E1 PRI.</p>
<i>POTS</i>	<p>Plain Old Telephone System. The conventional analog telephone line.</p>
<i>PRI</i>	<p>Priority Rate Interface. An ISDN interface designed for high volume data communication. Consists of 23 B channels of 64 Kbps each and one D channel of 64 Kbps. In Europe, the PRI line provides 30 B channels + one D channel.</p>
<i>QCIF</i>	<p>Quarter CIF. A video format with image size of 176x144 pixels that transmits 9.115 Mbps at 30 frames per second (a quarter of the capacity of CIF). See also CIF.</p>
<i>RS-232</i>	<p>A standard for serial interface connection.</p>
<i>SIP</i>	<p>Session Initiation Protocol. An application-layer protocol designed to work over IP networks. A SIP service defines the properties and the IP addresses of the SIP network components.</p>
<i>Span</i>	<p>An ISDN line or leased line. A span may be of either T1 (United States) or E1 (Europe) type. Also called a circuit.</p>
<i>Switched 56 line</i>	<p>A line using protocols pre-dating the ISDN protocols; also called a robbed bit signaling line or a pre-ISDN line.</p>

Abbreviation/ Term	Explanation
<i>T.120</i>	A standard for data and application sharing. Users can share and manipulate data as if they were in the same room.
<i>T1-CAS, T1 Line</i>	An 1.5 Mb digital switched line used in the United States.
<i>WAN</i>	Wide Area Network. A communications network that services a geographical area larger than the LAN.
<i>Whiteboard</i>	An on-screen shared notebook for placement of shared documents.

Free Manuals Download Website

<http://myh66.com>

<http://usermanuals.us>

<http://www.somanuals.com>

<http://www.4manuals.cc>

<http://www.manual-lib.com>

<http://www.404manual.com>

<http://www.luxmanual.com>

<http://aubethermostatmanual.com>

Golf course search by state

<http://golfingnear.com>

Email search by domain

<http://emailbydomain.com>

Auto manuals search

<http://auto.somanuals.com>

TV manuals search

<http://tv.somanuals.com>