

Tanaka

Parts Catalog

Trimmer/Brushcutter

Model: TBC-202

Units Prior To Serial No. F005800

TBC-205

OPTIONS AND ACCESSORIES

NYLON LINE



- 746156 .095, Box, 50 ft.
- 746157 .105, Box, 50 ft.
- 746160 .095, 1/2 lb. Box, 143 ft.
- 746161 .105, 1/2 lb. Box, 110 ft.
- 746165 .095, 1 lb. Box, 285 ft.
- 746166 .105, 1 lb. Box, 235 ft.
- 746169 .095, 3 lb. spool, 855 ft.
- 746170 .105, 3 lb. spool, 705 ft.
- 746173 .095, 5 lb. spool, 1425 ft.
- 746174 .105, 5 lb. spool, 1175 ft.

SEMI-AUTO HEAD



746153 PNH-180

Parts List

ET-1201	Body
ET-1206	Cap
ET-1225	Adapter
ET-1205	Spool
ET-1207	Eyelet
ET-1208	Spring
ET-1209	Bump Disk

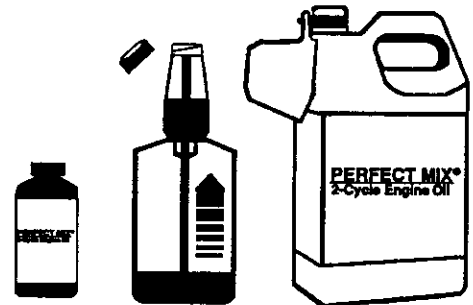
ALUMINUM MANUAL HEAD



PCH-100
(746180)

PCH-300
(746190)

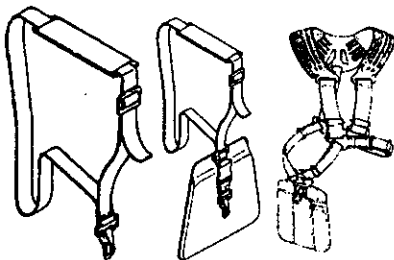
PERFECT MIX® 2-Cycle Engine Oil



- 700109 2.8 oz. Bottle, 1 Gallon Size (24*)
- 700108 16 oz. Self-measuring Bottle (24*)
- 700110 1 Gallon Jug Commercial Size (6*)
- * Case Quantity

TH-96 "Brain Head" can
be used on this unit

SHOULDER STRAPS



PSS-175 SS-250* SS-400*

* Requires 355-37302-900

BLADES



- 746101 Weed Blade, 9"X4T
- 746103 Weed Blade, 9"X48T
- 746104 Saw Blade, 9"X80T
- 746192 Carbide Blade, 9"X36T

MANUALS / CATALOGS

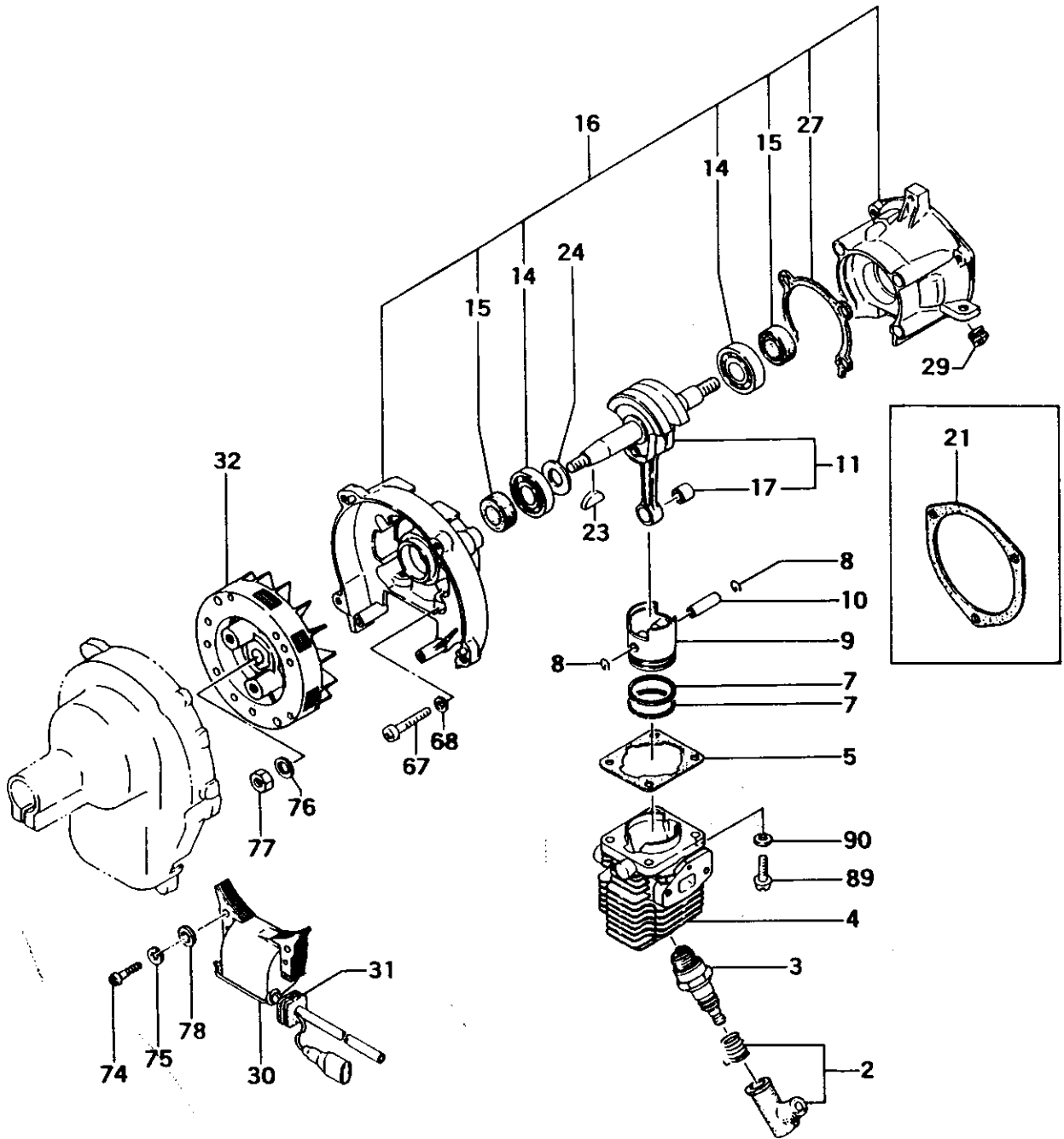
- | | |
|---------------|----------------|
| 970-33901-201 | Owner's Manual |
| DPL-BC205-HST | Parts Catalog |
| WSM-TBC | Service Manual |

SPECIAL TOOLS

- | | | | |
|---------------|--------------------|---------------|-----------------|
| 006-29326-000 | Flywheel Remover | 037-29376-000 | Clutch Remover |
| 009-29323-500 | Piston Pin Remover | 001-29000-000 | Tachometer |
| 015-29338-000 | Gear Shaft Remover | 070-2000W-500 | Pressure Tester |
| 016-29338-000 | Pinion Remover | 070-2000W-501 | Carb. Tool Kit |

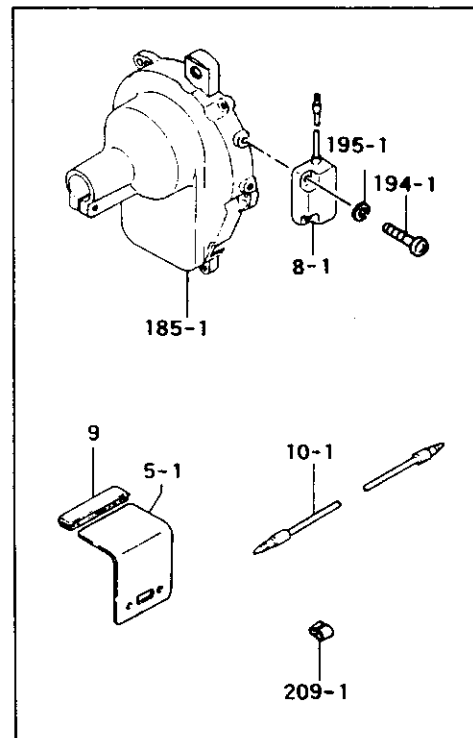
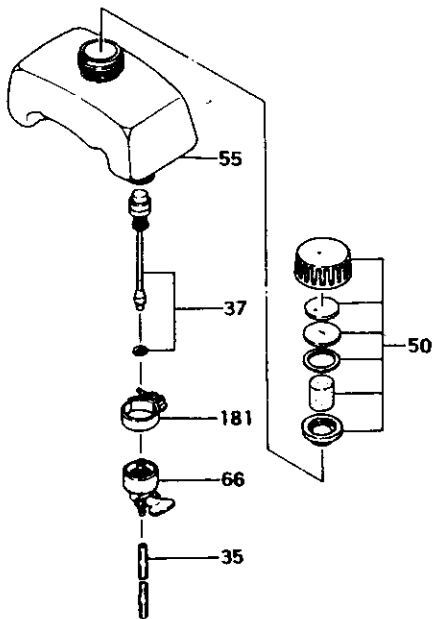
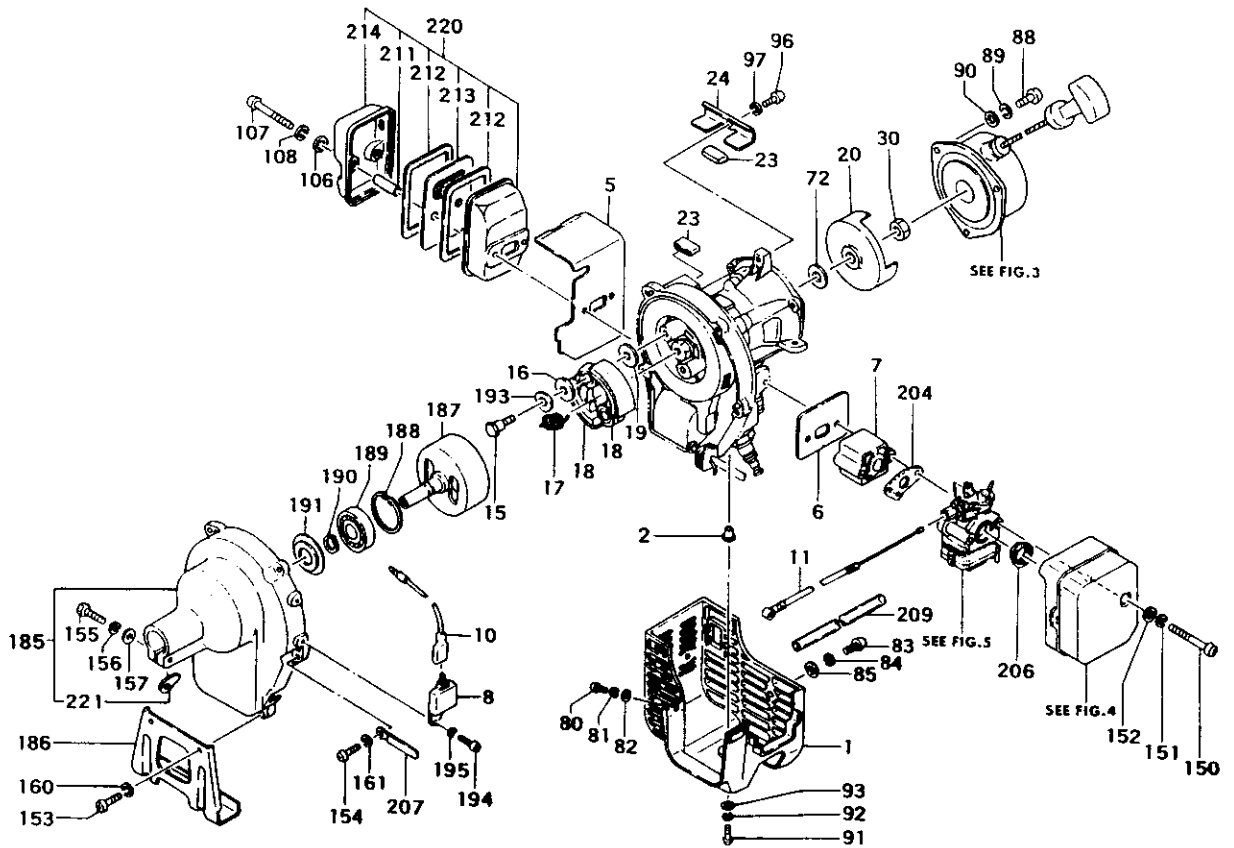


FIG.1 ENGINE



REF. NBR	PART NBR	PART NAME	QTY	SERIAL NBR	REMARKS
1-002	157-04000-900	SPARK PLUG CAP ASS'Y	1		
1-003	018-00502-200	SPARK PLUG BM6A	1		
1-004	002-0632R-800	CYLINDER COMP.	1	R -C219219	
1-004	002-0632R-801	CYLINDER COMP.	1	R -D131490	
1-004	002-06092-803	CYLINDER COMP.	1	D131491-	
1-005	017-06091-200	CYLINDER GASKET	1	I -E235500	
1-005	017-06091-201	CYLINDER GASKET	1	E235501-	
1-007	041-00000-200	PISTON RING	2		
1-008	039-06100-200	CIR CLIP	2		
1-009	031-06097-200	PISTON	1	I -D178755	
1-009	031-06097-201	PISTON	1	D178756-	
1-010	037-06097-200	PISTON PIN	1		
1-011	046-06091-800	CRANK SHAFT COMP.	1		
1-014	999-61600-100	BALL BEARING #6001, 28MM/OD	2		
1-015	999-66122-266	OIL SEAL 12227	2		
1-016	072-0632R-900	CRANK CASE ASS'Y	1		
1-017	999-62071-127	NEEDLE BEARING F-79	1		
1-021	810-06000-201	RECOIL STARTER GASKET	1	D E235501-	
1-023	068-10100-200	WOOD-RUFF KEY 3X13X4.5	1		
1-024	330-00200-210	GEAR SHAFT SHIM 0.10	V		
1-024	330-00200-220	GEAR SHAFT SHIM 0.15	V		
1-024	330-00200-230	GEAR SHAFT SHIM 0.20	V		
1-024	330-00200-240	GEAR SHAFT SHIM 0.30	V		
1-027	090-06000-201	CRANK CASE GASKET	1	R -C219219	
1-027	090-06000-202	CRANK CASE GASKET	1	C219220-	
1-029	203-06000-200	PRIMARY CORD GROMMET	1		
1-030	167-20745-801	IGNITION COIL COMP.	1		
1-031	203-10000-200	PRIMARY CORD GROMMET	1		
1-032	155-21702-800	MAGNETO ROTOR COMP.	1		
1-067	990-11050-301	SCREW 5X30	4		
1-068	992-10050-012	S. WASHER 5	4		
1-074	990-11040-181	SCREW 4X18	2	M	
1-074	990-11040-221	SCREW 4X22	2		
1-075	992-10040-012	S. WASHER 4	2		
1-076	065-00000-200	FLYWHEEL WASHER	1		
1-077	327-00201-200	NUT 7 (L. H. THREAD)	1		
1-078	992-00040-011	SMALL WASHER 4	2		
1-089	990-11050-161	SCREW 5X16	4		
1-090	992-10050-012	S. WASHER 5	4		

FIG.2 ENGINE COMPONENTS

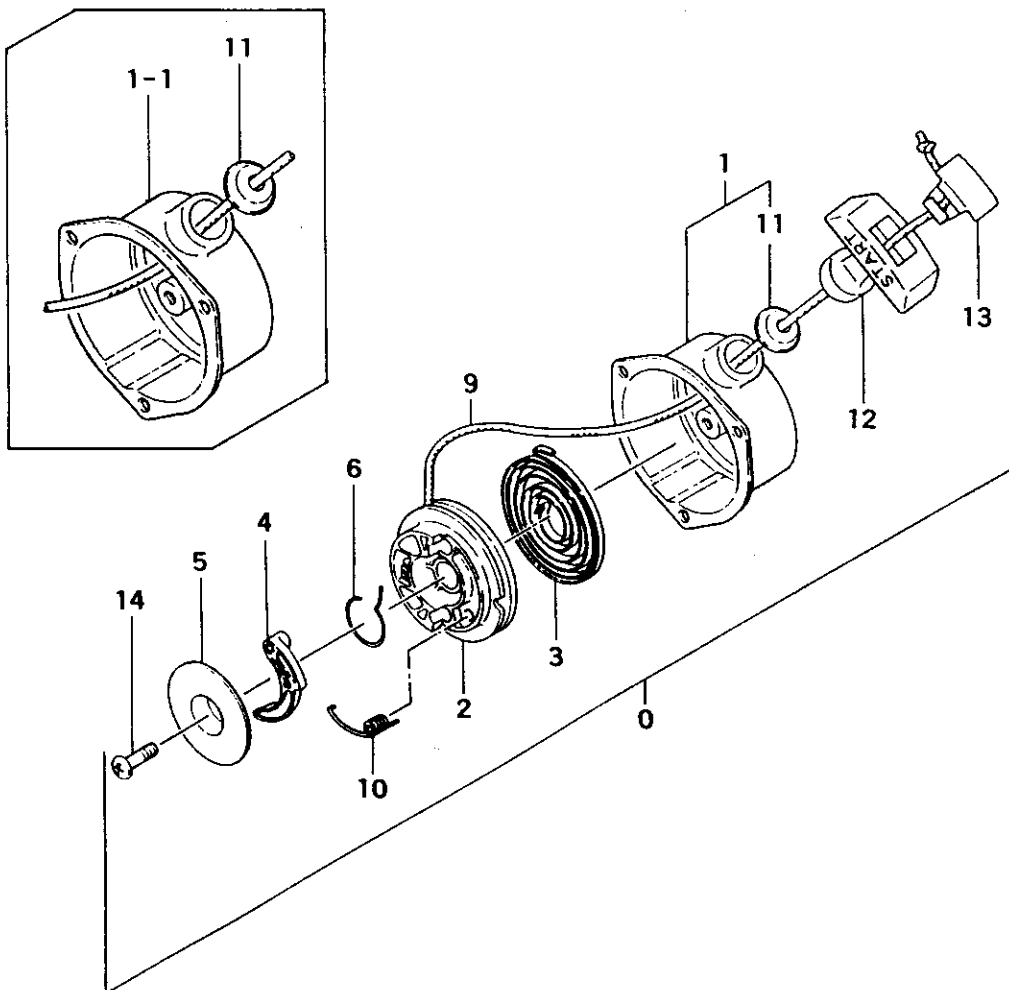


REF. NBR	PART NBR	PART NAME	QTY	SERIAL NBR	REMARKS
2-001	738-0632R-200	MUFFLER PROTECTOR	1	R -C171272	
2-001	738-0632R-201	MUFFLER PROTECTOR	1	C171273-	
2-002	011-0630B-200	CYLINDER COVER COLLAR	1		
2-005,1	133-0602K-200	HEAT SHIELD	1	R -C171272	
2-005,1	133-0602K-201	HEAT SHIELD	1	-D044240	
2-005,1	133-0602K-202	HEAT SHIELD	1	P -E068190	
2-005,1	133-0602K-202	HEAT SHIELD	1	R -E068190	
2-005	133-0602K-203	HEAT SHIELD	1	R -E235500	
2-005	133-0602K-204	HEAT SHIELD	1	E235501-	
2-006	403-0602K-201	INLET MANIFOLD GASKET	1		
2-007	404-0602K-200	CARBURETOR INSULATOR	1		
2-008,1	159-21401-871	IGNITOR COMP. TTI-1E	1	-D151567	
2-008	159-21401-872	IGNITOR COMP. TTI-1F	1	N D151568-	
2-009	599-0602K-200	CUSHION RUBBER	1	N C219220-	
2-009	599-0602K-200	CUSHION RUBBER	1	D E235501-	
2-010,1	178-0602K-800	STOP CORD COMP.	1	-D151567	
2-010	173-01620-800	IGNITOR LEAD WIRE COMP., R110M	1	N D151568-	
2-011	885-0602K-801	THROTTLE WIRE COMP.	1		
2-015	357-00601-200	STEP BOLT	2		
2-016	348-0602R-200	CLUTCH PLATE A	2		
2-017	342-00501-204	CLUTCH SPRING	1		
2-018	290-00501-802	CLUTCH SHOE COMP.	2		
2-019	359-02103-200	CLUTCH WASHER B	2		
2-020	798-06094-200	STARTER PULLEY	1		
2-023	655-06100-200	FUEL TANK CUSHION RUBBER	4		
2-024	653-06000-200	FUEL TANK BRACKET	1		
2-030	991-16080-003	NUT 8 (L.H. THREAD)	1		
2-035	700-03005-150	FUEL PIPE 3X5X150	1		
2-037	598-06020-900	PUMP FILTER ASS'Y	1		
2-050	595-0062A-910	TANK CAP ASS'Y, ORANGE	1	M	
2-050	595-0062A-901	TANK CAP ASS'Y	1		
2-055	591-0602K-200	FUEL TANK	1		
2-066	592-06666-901	PET-COCK ASS'Y	1		
2-072	359-10112-203	CLUTCH WASHER B	1		
2-080	990-11040-121	SCREW 4X12	1		
2-081	992-10040-012	S. WASHER 4	1		
2-082	992-01040-011	WASHER 4	1		
2-083	990-11050-121	SCREW 5X12	1		
2-084	992-10050-012	S. WASHER 5	1		
2-085	992-01050-011	WASHER 5	1		
2-088	990-11050-141	SCREW 5X14	3		
2-089	992-10050-012	S. WASHER 5	3		
2-090	992-01050-011	WASHER 5	3	M	
2-090	992-00050-011	SMALL WASHER 5	3		
2-091	990-11050-181	SCREW 5X18	1		
2-092	992-10050-012	S. WASHER 5	1		
2-093	992-01050-011	WASHER 5	1		
2-096	990-11050-141	SCREW 5X14	1		
2-097	992-10050-012	S. WASHER 5	1		
2-106	992-00050-011	SMALL WASHER 5	2		
2-107	990-11050-421	SCREW 5X42	2		
2-108	992-10050-012	S. WASHER 5	2		
2-150	990-11050-751	SCREW 5X75	2		
2-151	992-10050-012	S. WASHER 5	2		
2-152	992-00050-011	SMALL WASHER 5	2		
2-153	990-11050-121	SCREW 5X12	2		
2-154	990-11050-161	SCREW 5X16	4		
2-155	990-23050-206	H.T. BOLT 5X20	1		
2-156	992-10050-012	S. WASHER 5	1		
2-157	992-00050-011	SMALL WASHER 5	1		
2-160	992-10050-012	S. WASHER 5	2		
2-161	992-10050-012	S. WASHER 5	4		
2-181	680-06020-900	CLIP ASS'Y	1		

- To be cont'd -

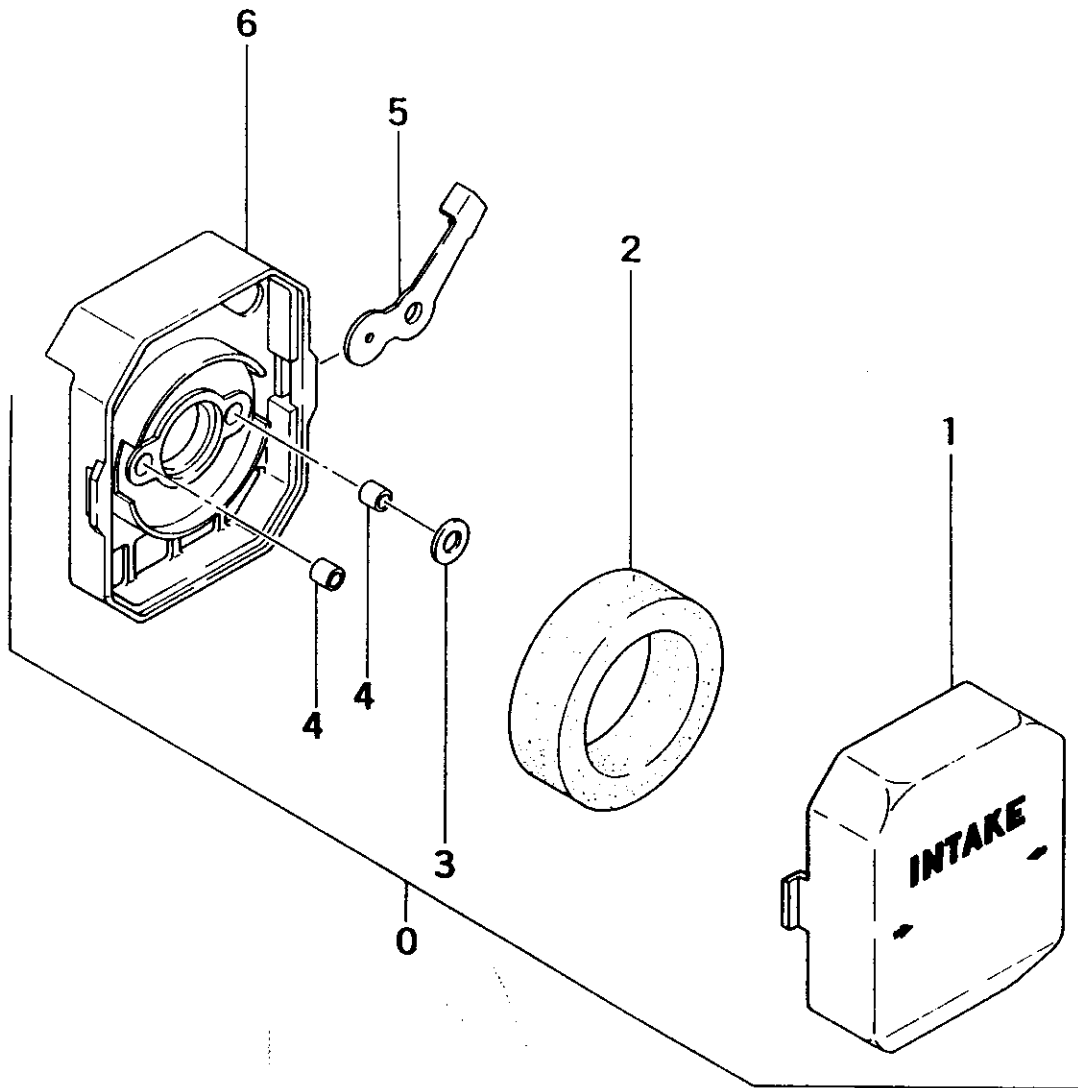
REF. NBR	PART NBR	PART NAME	QTY	SERIAL NBR	REMARKS
2-185,1	112-0602K-200	FAN CASE	1	-D151567	
2-185,1	112-0602K-201	FAN CASE	1	P -D151863	
2-185,1	112-0602K-201	FAN CASE	1	M	
2-185	112-0602K-210	FAN CASE	1	R -D217600	
2-185	112-0602K-220	FAN CASE	1	M	
2-185	112-0602K-800	FAN CASE SET	1	D217601-	
2-186	941-0602K-200	STAND	1		
2-187	289-06020-801	CLUTCH SHAFT COMP.	1		
2-188	993-51032-002	STOP RING C-32 1N	1		
2-189	999-61620-101	BALL BEARING #6201ZZ, 32MM/OD	1		
2-190	993-50012-002	STOP RING C-12 EX	1		
2-191	801-06020-200	STEP WASHER	1		
2-193	992-05080-030	BENT WASHER 8	2		
2-194,1	990-11040-161	SCREW 4X16	2	-D151567	
2-194	990-11040-081	SCREW 4X8	1	M D151568-	
2-195,1	992-10040-012	S. WASHER 4	2	-D151567	
2-195	992-10040-012	S. WASHER 4	1	D151568-	
2-204	402-0602K-200	CARBURETOR GASKET	1		
2-206	431-0602K-200	AIR CLEANER GASKET	1		
2-207	198-01046-900	CORD CLAMP ASS'Y	1		
2-209,1	778-36100-200	CORD CLAMP	1	-C191805	
2-209	264-0602K-200	CORD PROTECTION VINYL	1	N C191806-	
2-211	740-0602B-201	MUFFLER COLLAR	2		
2-212	739-0602B-200	MUFFLER COUPLING GASKET	2		
2-213	722-0602B-800	MUFFLER PARTITION PLATE COMP.	1		
2-214	717-0602B-200	MUFFLER BODY B	1		
2-220	706-0602B-900	MUFFLER ASS'Y W/ARRESTER	1		
2-221	324-33900-200	GEAR CASE WASHER	1	N D217601-	

FIG.3 RECOIL STARTER



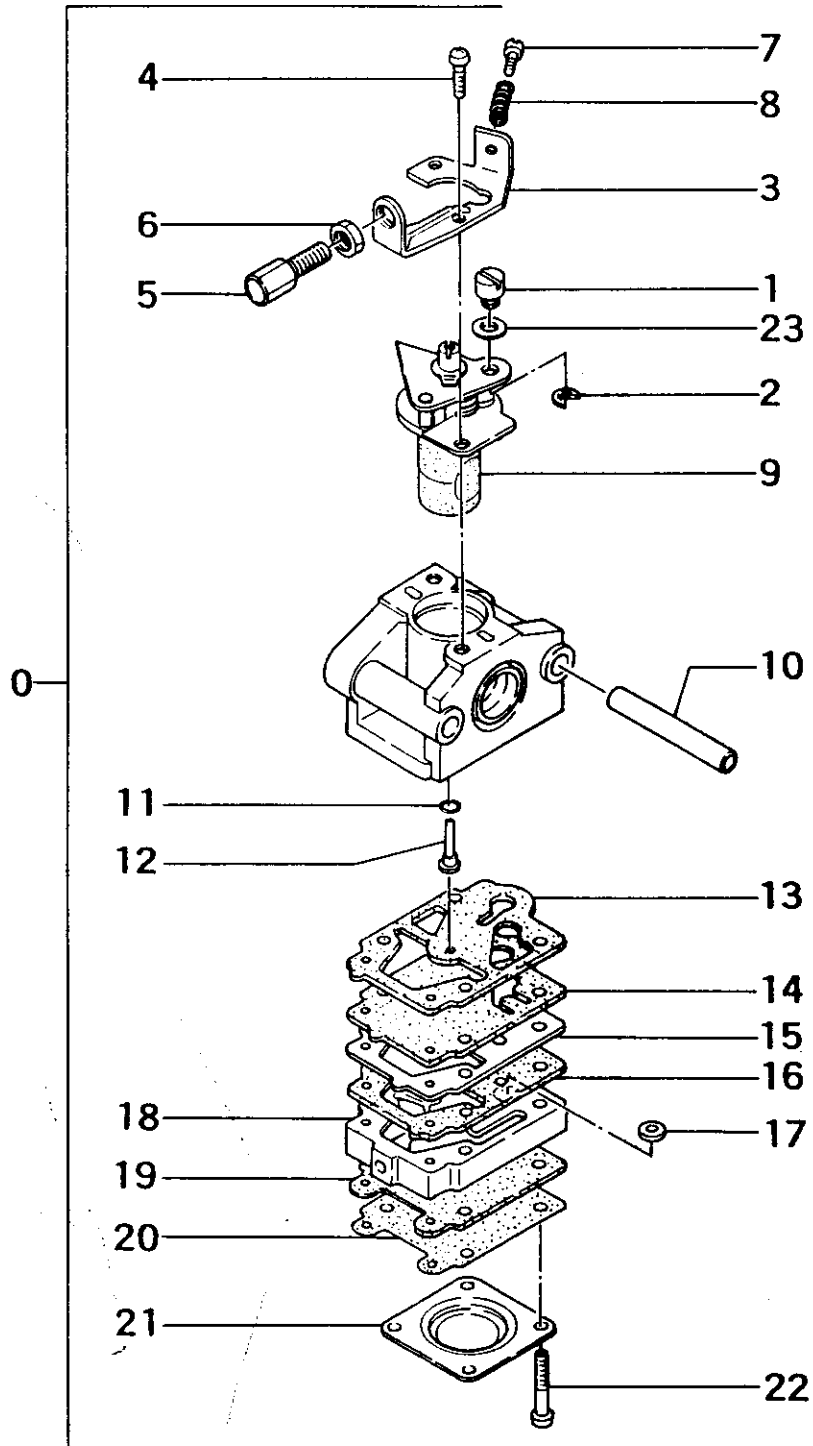
REF. NBR	PART NBR	PART NAME	QTY	SERIAL NBR	REMARKS
3-000	762-0602K-900	RECOIL STARTER BODY ASS'Y	1	I -E235500	
3-000	762-0602K-901	RECOIL STARTER BODY ASS'Y	1	E235501-	
3-001.1	772-0601R-200	RECOIL STARTER BODY	1	-E235500	
3-001.1	772-0601R-210	RECOIL STARTER BODY	1	N -E278205	
3-001.1	772-0601R-210	RECOIL STARTER BODY	1	R -E278205	
3-001	772-0601R-800	RECOIL STARTER BODY COMP.	1	E278206-	
3-002	769-06092-200	STARTER ROPE REEL	1		
3-003	779-06092-200	RECOIL SPRING	1	M	
3-003	779-01250-200	RECOIL SPRING	1		
3-004	788-06092-200	STARTER PAWL	1		
3-005	837-06092-200	FRICTION PLATE	1		
3-006	836-01250-200	FRICTION SPRING	1	M	
3-008	836-06092-200	FRICTION SPRING	1		
3-009	783-06092-200	ROPE 3.5X890L	1		
3-010	832-06092-200	RETURN SPRING	1		
3-011	782-06097-200	ROPE GUIDE	1	-E235500	
3-011	782-0602K-200	ROPE GUIDE	1	N E235501-	
3-012	785-06097-200	STARTER HANDLE	1		
3-013	795-0602K-200	STARTER HANDLE CAP	1		
3-014	990-15050-121	SCREW 5X12	1	-E235500	
3-014	990-15050-126	SCREW 5X12	1	N E235501-	

FIG.4 AIR CLEANER



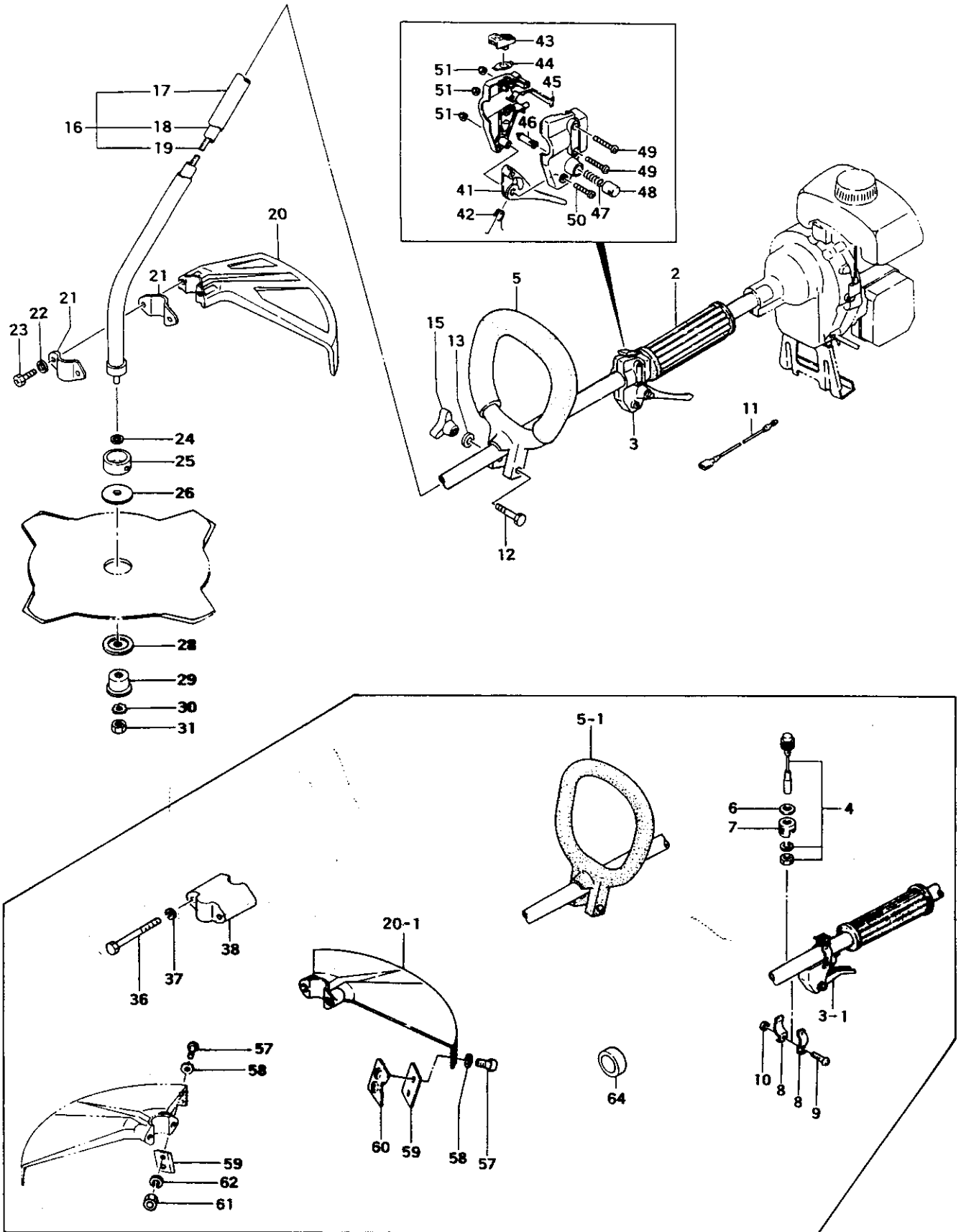
REF. NBR	PART NBR	PART NAME	QTY	SERIAL NBR	REMARKS
4-000	410-0602D-901	AIR CLEANER ASS'Y	1		
4-001	424-0602K-200	AIR CLEANER CAP	1	R -E235500	
4-001	424-0602K-201	AIR CLEANER CAP	1	E235501-	
4-002	446-0602K-200	CLEANER ELEMENT	1		
4-003	453-0602K-200	SPACER	1		
4-004	470-0602K-200	COLLAR	2		
4-005	528-0602D-200	CHOKE PLATE,V/2MM HOLE	1		
4-006	423-0602K-200	CLEANER BODY	1	-E235500	
4-006	423-0602K-210	CLEANER BODY	1	N E235501-	

FIG.5 CARBURETOR



REF. NBR	PART NBR	PART NAME	QTY		SERIAL NBR	REMARKS
5-000	455-25101-900	CARBURETOR ASS'Y	1	R	-D204250	
5-000	455-25101-910	CARBURETOR ASS'Y, WY-68	1		D204251-	
5-001	539-25006-200	SWIVEL	1	R	-D151567	
5-001	539-25100-200	SWIVEL	1	H		
5-001	539-25101-200	SWIVEL	1		D151568-	
5-002	489-25100-200	STOP RING	1			
5-003	544-25100-200	ADJUSTER STAY	1			
5-004	514-25100-200	THROTTLE SET SCREW	2			
5-005	614-25100-200	CABLE ADJUSTER	1			
5-006	613-25100-200	CABLE ADJUST NUT	1			
5-007	462-25100-200	IDLE ADJUST SCREW	1		-D151567	
5-007	462-25100-201	IDLE ADJUST SCREW	1	P	D151568-	
5-008	463-25100-200	IDLE ADJUST SPRING	1			
5-009	488-25100-800	THROTTLE VALVE COMP.	1		-D204250	
5-009	488-25100-810	THROTTLE VALVE COMP.	1	N	D204251-	
5-010	437-25100-200	SLEEVE	2			
5-011	550-25100-200	O-RING	1			
5-012	599-25100-200	MAIN JET	1	M		
5-012	599-25100-440	MAIN JET #44	1		-D204250	
5-012	599-25100-244	MAIN JET #44	1	H		
5-012	599-2000W-440	MAIN JET #44	1	N	D204251-	
5-013	577-25100-200	PUMP GASKET	1			
5-014	576-25100-200	PUMP DIAPHRAGM	1			
5-015	523-25100-200	PUMP PLATE	1	R	-D151567	
5-015	523-25100-201	PUMP PLATE	1		D151568-	
5-016	522-25100-200	CIRCUIT PLATE	1			
5-017	578-25001-200	INLET SCREEN	1			
5-018	575-25100-800	PUMP BODY COMP.	1		-D204250	
5-018	575-25100-810	PUMP BODY COMP.	1	N	D204251-	
5-019	475-25001-200	DIAPHRAGM GASKET	1			
5-020	474-25001-800	METERING DIAPHRAGM COMP.	1			
5-021	476-25006-200	DIAPHRAGM COVER	1	M		
5-021	476-25004-200	DIAPHRAGM COVER	1			
5-022	548-25101-200	SET SCREW	4			
5-023	594-25100-200	THRUST WASHER	1	M		
5-023	549-25100-200	THRUST WASHER	1	N	D151568-	

FIG.6 DRIVE SHAFT & HANDLE

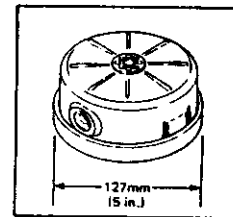
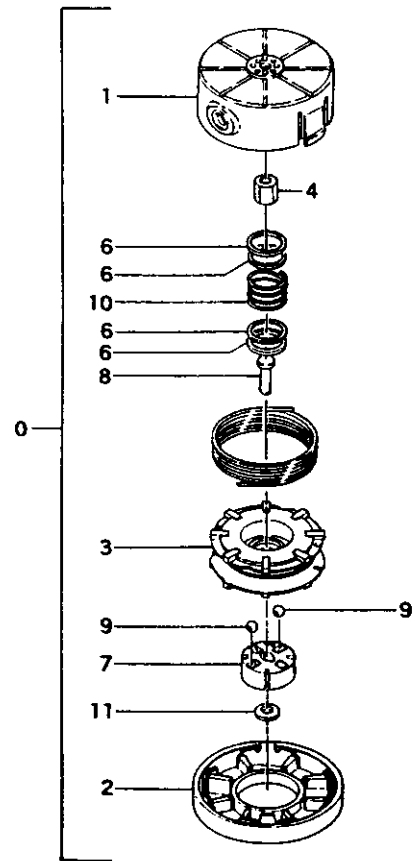
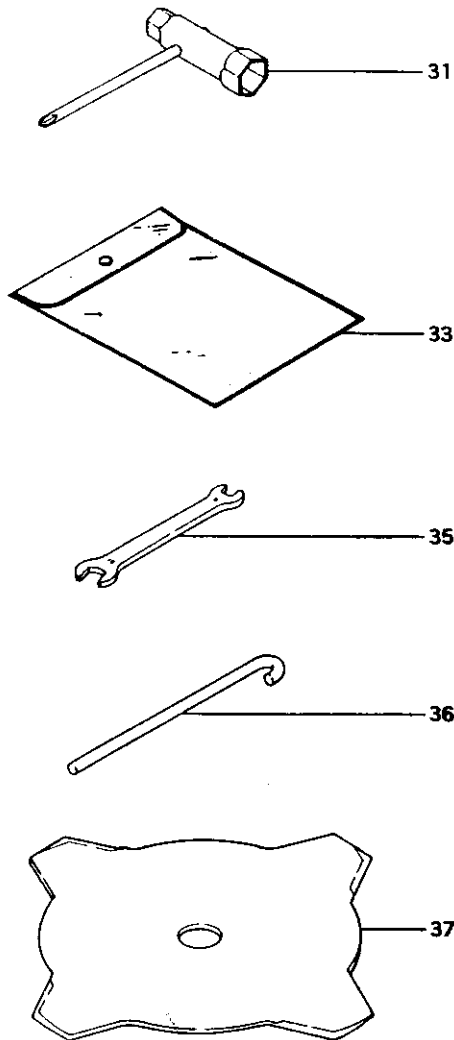


REF. NBR	PART NBR	PART NAME	QTY	SERIAL NBR	REMARKS
6-002	504-33700-201	SHAFT GRIP	1		
6-003, 1	870-33703-900	THROTTLE LEVER ASS'Y	1	-D151567	
6-003	870-33005-900	THROTTLE LEVER ASS'Y	1	N -E235500	
6-003	870-33005-901	THROTTLE LEVER ASS'Y	1	P E235501-	
6-004	170-00741-800	STOP BUTTON COMP.	1	D D151568-	
6-005, 1	500-33700-202	HANDLE	1	R -C171272	
6-005, 1	500-33700-203	HANDLE	1	R -E235500	
6-005	500-33006-800	HANDLE COMP.	1	E235501-	
6-006	992-01080-011	WASHER 8	1	D D151568-	
6-007	640-33005-200	STOP BUTTON BRACKET	1	D D151568-	
6-008	115-33210-200	BRACKET	2	M	
6-008	115-33210-202	BRACKET	2	D D151568-	
6-009	990-11040-161	SCREW 4X16	1	D D151568-	
6-010	991-01040-011	HEX. NUT 4	1	D D151568-	
6-011	178-33005-800	STOP CORD COMP.	1	N D151568-	
6-012	990-21060-501	BOLT 6X50	1		
6-013	359-02103-200	CLUTCH WASHER B	1		
6-015	512-33700-800	HANDLE KNOB COMP.	1		
6-016	341-33006-910	DRIVE SHAFT PIPE ASS'Y	1		
6-017	341-33005-810	DRIVE SHAFT PIPE COMP.	1	M	
6-017	341-33006-810	DRIVE SHAFT PIPE COMP.	1		
6-018	350-33006-800	FLEXIBLE LINER COMP.	1		
6-019	344-33005-210	FLEXIBLE SHAFT	1	I -D224950	
6-019	344-33006-211	FLEXIBLE SHAFT	1	D224951-	
6-020, 1	441-33005-200	SAFETY GUARD	1	R -C219219	
6-020, 1	441-33005-201	SAFETY GUARD	1	-D151567	
6-020	441-33006-800	SAFETY GUARD COMP.	1	N D151568-	
6-021	442-33006-200	GUARD BRACKET	1	-D151567	
6-021	442-33005-200	SAFETY GUARD BRACKET	2	M	
6-021	442-33006-200	GUARD BRACKET	2	D151568-	
6-022	992-10060-012	S. WASHER 6	2		
6-023	990-21060-151	BOLT 6X15	2	R -D151567	
6-023	990-23060-151	BOLT 6X15 W/PLUS	2	D151568-	
6-024	760-33005-200	SPECIAL WASHER	1		
6-025	370-33005-210	CUTTER CASE COVER	1		
6-026	310-33005-200	CUTTER HOLDER	1	N E235501-	
6-028	311-33005-200	CUTTER HOLDER CAP	1	N E235501-	
6-029	316-33005-200	BOLT PROTECTION COVER	1	N E235501-	
6-030	992-29080-000	TOOTHED LOCK WASHER 8 L/H	1	N E235501-	
6-031	991-06080-001	NUT 8/L.H. THREAD	1	N E235501-	
6-036	990-21060-701	BOLT 6X70	2	D D151568-	
6-037	992-10060-012	S. WASHER 6	2	D D151568-	
6-038	444-33006-200	BRACKET SPACER	1	M	
6-038	444-33005-200	BRACKET SPACER	1	D D151568-	
6-041	880-33564-200	THROTTLE ARM	1	N D151568-	
6-042	832-33564-200	RETURN SPRING	1	N D151568-	
6-043	162-33564-200	STOP SWITCH	1	N D151568-	
6-043	162-33564-200	STOP SWITCH	1	-E235500	
6-043	162-33564-210	STOP SWITCH	1	N E235501-	
6-044	262-33564-200	STOP SWITCH SPRING	1	N D151568-	
6-045	176-33564-200	EARTH TERMINAL	1	N D151568-	
6-046	956-33564-200	LOCK BUTTON A	1	N D151568-	
6-047	958-33564-200	LOCK BUTTON SPRING	1	N D151568-	
6-048	957-33564-200	LOCK BUTTON B	1	N D151568-	
6-049	994-31050-301	SCREW 5X30	2	N D151568-	
6-050	994-31050-251	SCREW 5X25	1	N D151568-	
6-051	991-86050-000	SELF-LOCK NUT 5	3	N D151568-	
6-057	990-11040-161	SCREW 4X16	2	R -C219219	
6-057	990-11040-121	SCREW 4X12	2	C219220-	
6-057	990-11040-121	SCREW 4X12	2	D D151568-	
6-058	992-01040-011	WASHER 4	2	D D151568-	
6-059	800-33005-200	CORD CUTTER BLADE	1	I -C219219	
6-059	800-33005-201	CORD CUTTER BLADE	1	C219220-	

- To be cont'd -

REF. NBR	PART NBR	PART NAME	QTY	SERIAL NBR	REMARKS
6-059	800-33005-201	CORD CUTTER BLADE	1 D	D151568-	
6-060	799-33005-200	BLADE GUIDE	1 N	C219220-	
6-060	799-33005-200	BLADE GUIDE	1 D	D151568-	
6-061	991-01040-011	HEX. NUT 4	2 D	C219220-	
6-062	992-10040-012	S. WASHER 4	2 D	C219220-	
6-064	371-33005-200	CUTTER SHAFT SPACER	1 D	E235501-	

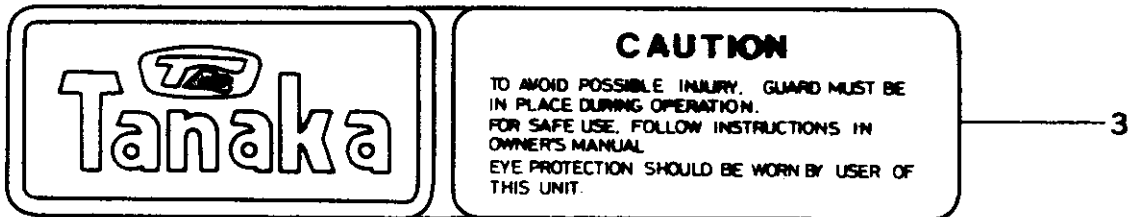
FIG.7 TOOLS & NYLON HEAD



TH-95S

REF. NBR	PART NBR	PART NAME	QTY	SERIAL NBR	REMARKS
7-000	783-33004-900	NYLON HEAD ASS'Y (TH-95S)	1	R -E068190	
7-000	783-33004-901	NYLON HEAD ASS'Y (TH-95S)	1	E068191-	
7-001	786-33004-800	CUTTING BODY COMP.	1	R -E068190	
7-001	786-33004-801	CUTTING BODY COMP.	1	E068191-	
7-002	789-33004-201	BODY CAP	1		
7-003	787-33004-201	CORD REEL	1	R -E068190	
7-003	787-33004-202	CORD REEL	1	E068191-	
7-004	315-33004-200	DRIVE NUT L/H GOLD	1		
7-006	792-33004-200	REEL WASHER	4		
7-007	790-33004-200	REEL SLIDER	1		
7-008	791-33004-200	REEL SLIDER HOOK	1		
7-009	673-35600-200	STEEL BALL 5/16"	2		
7-010	793-33004-201	REEL SPRING (BLACK)	1		
7-011	358-02103-200	WASHER	1		
7-031	829-20000-800	COMBI. BOX SPANNER 13X19 ,PLUS	1		
7-033	948-32352-200	TOOL BAG	1		
7-035	801-20000-200	SPANNER 8X10	1		
7-036	752-33005-200	LOCK HANDLE	1		
7-037	802-33701-200	BLADE 4 TEETH 200	1	D D178756-	
7-037	802-33410-200	4 TOOTHED BLADE, 230	1	N E235501-	

FIG.8 MARKS



REF. NBR	PART NBR	PART NAME	QTY	SERIAL NBR	REMARKS
8-001	906-43005-200	NAME PLATE	1		
8-002	923-33700-200	LEVEL MARK	1		
8-003	929-33006-200	SYMBOL MARK	1		

Free Manuals Download Website

<http://myh66.com>

<http://usermanuals.us>

<http://www.somanuals.com>

<http://www.4manuals.cc>

<http://www.manual-lib.com>

<http://www.404manual.com>

<http://www.luxmanual.com>

<http://aubethermostatmanual.com>

Golf course search by state

<http://golfingnear.com>

Email search by domain

<http://emailbydomain.com>

Auto manuals search

<http://auto.somanuals.com>

TV manuals search

<http://tv.somanuals.com>