

**FAILURE TO READ AND FOLLOW ALL INSTRUCTIONS CAREFULLY BEFORE
INSTALLING OR OPERATING THIS CONTROL COULD CAUSE PERSONAL
INJURY AND/OR PROPERTY DAMAGE.**

DESCRIPTION

Kit includes:

- 1 – 50A66-843 ignition control board
- 1 – Wiring harness (9-pin to 12-pin)
- 1 – Wiring harness (4-pin to 6-pin)
- 1 – Mounting panel
- 4 – Stand-off fasteners
- 1 – Circuit breaker
- 1 – 4" blue wire
- 2 – Wiring diagrams

The kit includes the 50A66-843 which is an automatic gas interrupted ignition control that employs a microprocessor to continually monitor, analyze, and control the proper operation of the gas burner, inducer, and fan.

These controls incorporate system fault analysis for quick gas flow shut-off, coupled with automatic ignition retry upon sensing a fault correction.

The 21D83M-843 kit will replace the following Controls:

Lennox	White-Rodgers	Page	Reference
10M9301 32M8801 12L6901 56L8401	50A65-120 50A65-121	3	PROCEDURE 1 Figure 1, Picture 1, Table 1, Wiring Diagram 5001-6973
24L8501 63K8901 97L4801	50A62-120 50A62-121 50A62-820	4	PROCEDURE 2 Figure 1, Picture 2, Table 2, Wiring Diagram 5001-6972
100925-01 30W2501 100925-03 69M0801 17W9201 69M1501 23W5101 83M00	21D83M-843 50A66-122 50A66-123	5	PROCEDURE 3

Follow instructions for replacement of your model number under the heading **INSTALLATION**.

PRECAUTIONS

Installation should be done by a qualified heating and air conditioning contractor or licensed electrician.

If in doubt about whether your wiring is millivolt, line, or low voltage, have it inspected by a qualified heating and air conditioning contractor or licensed electrician.

Do not exceed the specification ratings.

All wiring must conform to local and national electrical codes and ordinances.

This control is a precision instrument, and should be handled carefully. Rough handling or distorting components could cause the control to malfunction.

Following installation or replacement, follow manufacturer's recommended installation/service instructions to ensure proper operation.

CAUTION

Do not short out terminals on gas valve or primary control. Short or incorrect wiring may damage the thermostat.

WARNING

Failure to comply with the following warnings could result in personal injury or property damage.

FIRE HAZARD

- Do not exceed the specified voltage.
- Replace existing control with exact model and dash number.
- Protect the control from direct contact with water (dripping, spraying, rain, etc.).
- If the control has been in direct contact with water, replace the control.
- Label all wires before disconnection when servicing controls. Wiring errors can cause improper and dangerous operation.
- Route and secure wiring away from flame.

SHOCK HAZARD

- Disconnect electric power before servicing.
- Ensure proper earth grounding of appliance.
- Ensure proper connection of line neutral and line hot wires.

EXPLOSION HAZARD

- Shut off main gas to appliance until installation is complete.

SPECIFICATIONS

ELECTRICAL RATINGS [@ 77°F (25°C)]:

Input Voltage: 25 VAC 50/60 Hz

Max. Input Current @ 25 VAC: 0.45 amp

Relay Load Ratings:

Valve Relay: 1.5 amp @ 25 VAC 50/60 Hz 0.6 pf

Ignitor Relay: 2.0 amp @ 120 VAC 50/60 Hz
(resistive)

Inducer Relay: 2.2 FLA–3.5 LRA @ 120 VAC

Circulator Relay: 14.5 FLA–25.0 LRA @ 120 VAC

Flame Current Requirements:

Minimum current to insure flame detection: 0.25 µA DC*

Maximum current for non-detection: 0.1 µA DC*

Maximum allowable leakage resistance: 100 M ohms

*Measured with a DC microammeter in the flame probe lead

OPERATING TEMPERATURE RANGE:

-40° to 175°F (-40° to 80°C)

HUMIDITY RANGE:

5% to 93% relative humidity (non-condensing)

MOUNTING:

Surface mount multipoise

Timing Specs: (@ 60 Hz**)

	maximum
Flame Establishing Time:	0.8 sec
Flame Failure Response Time:	2.0 sec

**At 50 Hz, all timing specifications should be increased by 20%

Gases Approved: Natural, Manufactured, Mixed, Liquefied Petroleum, and LP Gas Air Mixtures are all approved for use.

TIMING SPECIFICATIONS (All times are in seconds, unless noted otherwise)

Event	Definition	50A66-843
Pre-Purge	The period of time intended to allow for the dissipation of any unburned gas or residual products of combustion at the beginning of a furnace operating cycle prior to initiating ignition	15
Trial for Ignition Period (TFI)	The period of time between initiation of gas flow and the action to shut off the gas flow in the event of failure to establish proof of the supervised ignition source or the supervised main burner flame.	4
Ignition Activation Period (IAP)	The period of time between energizing the main gas valve and deactivation of the ignition means prior to the end of TFI	4
Retries	The additional attempts within the same thermostat cycle for ignition when the supervised main burner flame is not proven within the first trial for ignition period.	4 times
Valve Sequence Period	Valve sequence period equals 4 seconds trial for ignition period x (1 initial try + 2 retries) + 12 seconds.	20
Interpurge	The period of time intended to allow for the dissipation of any unburned gas or residual products of combustion between the failed trial for ignition and the retry period.	15
Post-Purge	The period of time intended to allow for the dissipation of any unburned gas or residual products of combustion at the end of a furnace burner operating cycle. Post-purge begins at the loss of flame sense.	5
Lockout Time	ANSI standard rated module timing.	250
Heat Delay-To-Fan-On	The period of time between proof of the supervised main burner flame and the activation of the blower motor at Heat speed.	45
Heat Delay-To-Fan-Off*	The period of time between the loss of a call for heat and the deactivation of the blower motor at Heat speed.	60/90/120/180
Cool Delay-To-Fan-On	The period of time after a thermostat demand for cool before energizing the circulator blower motor at Cool speed.	2
Cool Delay-To-Fan-Off*	The period of time between the loss of a call for cool and the deactivation of the blower motor at Cool speed.	2/45
Ignitor Warm-up	The length of time allowed for the igniter to heat up prior to the initiation of gas flow.	20
Auto Reset	After one (1) hour of internal or external lockout, the control will automatically reset itself and go into an auto restart purge for 60 seconds.	60 minutes
Humidifier		Yes
Electronic Air Cleaner		Yes

*This time will vary depending on option switch position. The control is factory set at 90 seconds HEAT delay-to-fan-off and 45 seconds COOL delay-to-fan-off. See OPERATION section for further information

⚠ WARNING

FIRE HAZARD

- Do not exceed the specified voltage.
- Replace existing control with exact model and dash number.
- Protect the control from direct contact with water (dripping, spraying, rain, etc.).
- If the control has been in direct contact with water, replace the control.
- Label all wires before disconnection when servicing controls. Wiring errors can cause improper and dangerous operation.
- Route and secure wiring away from flame.

SHOCK HAZARD

- Disconnect electric power before servicing.
- Ensure proper earth grounding of appliance.
- Ensure proper connection of line neutral and line hot wires.

EXPLOSION HAZARD

- Shut off main gas to appliance until installation is complete.

⚠ CAUTION

Do not short out terminals on gas valve or primary control. Short or incorrect wiring may damage the thermostat.

MOUNTING PANEL

The Mounting Panel is required in Procedure 1 and Procedure 2. It will become part of the installation for Procedure 1. It will be used as a template for locations to drill holes in Procedure 2, Step 4A and 4B. It will become part of the installation in Procedure 2, Step 4C.

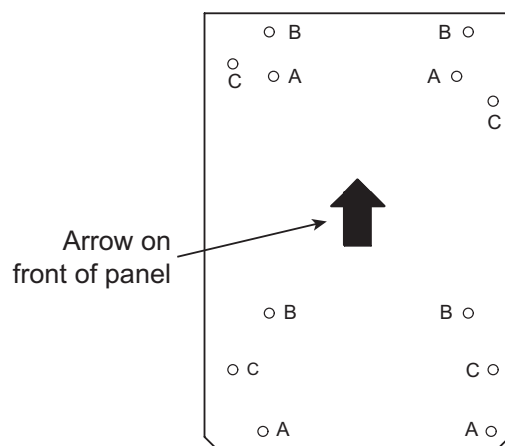

Figure 1 – Mounting Panel

PROCEDURE 1

REPLACING 10M9301, 12L6901, 32M8801, 50A65-120, 50A65-121 or 56L8401

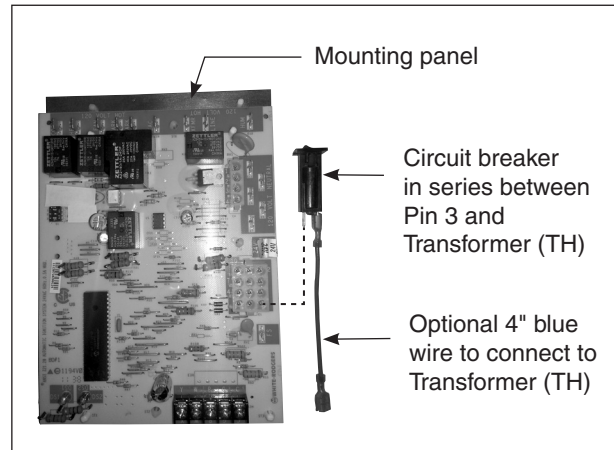

Photo 1

1. Disconnect all electrical power and shut off the gas supply to the furnace.
2. Remove the access panel.
3. Disconnect wiring and remove existing ignition control board from the control box.
4. Install provided circuit breaker in unit control box or secure circuit breaker to a wire harness using wire ties.
5. Position the provided mounting panel with the arrow on the front of the panel pointing up. Position the replacement 50A66-843 ignition control board over the holes marked "A" in figure 1. Insert the replacement control stand-off fasteners into the holes in the mounting panel.
6. Insert the four provided stand-off fasteners into the back of the mounting panel in the holes marked "B" in figure 1. Insert the replacement control board assembly into the existing holes in the control box or blower panel.
7. Insert provided circuit breaker in series between the blue transformer wire connecting position 3 on the 12-pin connector to the transformer (TH), optional 4" blue wire provided for transformers that have a quick-connect terminal.
8. Connect the remaining 120 VAC hot and neutral wires and the flame sense wire to the replacement control per table 1, page 4.
9. Affix wiring diagram 5001-6973 adjacent to the existing unit wiring diagram.
10. Replace the access panel.
11. Restore the electrical power and gas supply. Refer to the furnace installation instructions for start-up and check-out procedures.

INSTALLATION

TABLE 1

Type	Existing Control Board	Replacement Control Board
L1 120 VAC	COOL-H	COOL
	HEAT-H	HEAT
	PARK (2)	PARK (2)
	EAC-H	EAC
	LINE-H	LINE
	XFMR-H	XFMR
	HUM-H	HUM
Neutral 120 VAC	NONE	FAN
	LINE-N	Neutral 120 VAC (5)
	HUM-N	
	EAC-N	
	XFMR-N	
CIR-N		
Flame Sense	E33	FS

PROCEDURE 2

REPLACING 24L8501, 50A62-120, 50A62-121, 50A62-820, 56L8301, 63K8901 or 97L4801

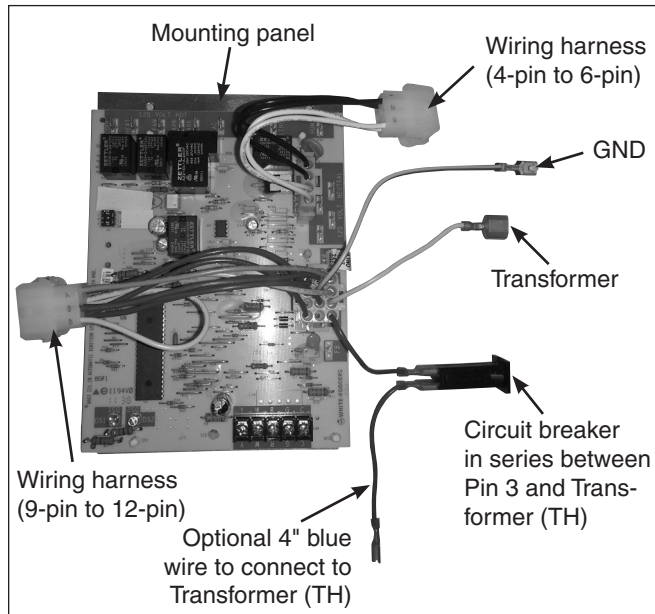

Photo 2

1. Disconnect all electrical power and shut off the gas supply to the furnace.
2. Remove the access panel.
3. Disconnect wiring and remove existing ignition control board from the control box.
4. A. **When replacing original 63K8901 board in upflow or horizontal applications or downflow applications** – Look at the existing control board holes as if the unit were installed in the upflow position. Make a mark 1" to the right of each of the existing mounting holes. Position the provided mounting panel so that the holes marked "C" in figure 1, page 3 are

over the marks. Use the mounting panel as a template to drill 3/16" holes through each of the holes marked "A". Install the replacement control in the freshly drilled holes in the blower access panel. Use aluminum tape to seal the unused holes.

- B. **When replacing original 63K8901 board in downflow applications** – Look at the existing control board holes as if the unit were installed in the upflow position. Make a mark 5/8" ABOVE each of the existing mounting holes. Position the provided mounting panel so that the holes marked "C" in figure 1, page 3 are over the marks. Use the mounting panel as a template to drill 3/16" holes through each of the holes marked "A". Install the replacement control in the freshly drilled holes in the blower access panel. Use aluminum tape to seal the unused holes.
- C. **All other units** – Position the provided mounting panel so that the arrow on the front of the panel is pointing up. Position the replacement 50A66-843 ignition control board over the holes marked "A" in figure 1, page 3. Insert the replacement control stand-off fasteners into the holes in the mounting panel. **80UHG, 90UGF, G23, G26, GHR26, G32, GHR32, G40, G41, G50, G51, G60 and G61 units** – Insert the four provided stand-off fasteners into the back of the mounting panel in the holes marked "B" in figure 1. **80MGF, G24M and G27M units** – Insert the four provided stand-off fasteners into the back of the mounting panel into the holes marked "C" in figure 1. Insert the replacement control board assembly into the existing holes in the control box or blower panel.
5. Insert provided circuit breaker in series between the blue wire on Pin 3 of the wiring harness (9-pin to 12-pin) and the blue transformer wire. Optional 4" blue wire provided for transformers that have a quick-connect terminal.
6. Connect the provided 9-pin to 12-pin wiring harness to the unit 9-pin connector.
7. Connect the provided 4-pin to 6-pin wiring harness to the unit 6-pin connector.
8. Connect the yellow wire from position 6 on the 12-pin connector to the yellow transformer wire.
9. Connect GND wire to equipment ground.
10. Connect the remaining 120 VAC hot and neutral wires and the flame sense wire to the replacement control per table 2, page 5 .
11. Affix wiring diagram 5001-6972 adjacent to the existing unit wiring diagram
12. Replace the access panel.
13. Restore the electrical power and gas supply. Refer to the furnace installation instructions for start-up and check-out procedures.

TABLE 2

Type	Existing Control Board	Replacement Control Board
L1 120 VAC	ACB COOL	COOL
	ACB HEAT	HEAT
	PARK M1	PARK
	PARK M2	PARK
	ACC	EAC
	120 VAC HOT	LINE
	120 VAC TX	XFMR
	HTG ACC	HUM
	ACB LOW	FAN
Neutral 120 VAC	Neutral 120 VAC Return (5)	Neutral 120 VAC (5)
Flame Sense	E33	FS

PROCEDURE 3

**REPLACING 100925-01, 100925-02,
100925-03, 17W9201, 23W5101,
30W2501, 50A66-122, 50A66-123,
69M0801 or 69M1501**

1. Disconnect all electric power and shut off gas supply to the furnace.
2. Remove the access panel
3. Disconnect wiring and remove existing ignition control board.
4. Insert the replacement board into existing holes.
5. Reconnect wiring.
6. Replace access panel.
7. Restore the electrical power and gas supply. Refer to the furnace installation instructions for start-up and check-out procedures.

OPERATION

OPTION SWITCHES

The option switches on the 50A66-843 control are used to determine the length of the heat delay-to-fan-off and cool-delay-to-fan-off periods. The following table shows the time periods that will result from the various switch positions.

OPTION SWITCH POSITIONS

HEAT delay-to-fan-off:	Set switch	
	#1	#2
60 sec.	Off	Off
90 sec.*	Off	On
120 sec.	On	Off
180 sec.	On	On

COOL delay-to-fan-off:	Set switch
	#3
2 sec.	Off
45 sec.*	On

*Factory Setting

HEAT MODE

In a typical system, a call for heat is initiated by closing the thermostat contacts. This starts the 50A66-843 control's heating sequence. The inducer blower and humidifier are energized. After a 15-second pre-purge period, the 768A Silicon Nitride ignitor is powered.

This controller has an adaptive algorithm that reduces ignitor temperature to slightly greater than the minimum temperature required to ignite gas in each particular application. The control measures the line voltage and determines an initial ignitor temperature setting based on the measurement. After each successful ignition, the control lowers the ignitor temperature slightly for the next ignition attempt. The control continues to lower the ignitor temperature until ignition does not occur, and the control

goes into retry mode. For the second attempt to ignite gas within the same call for heat, the control increases the ignitor temperature to the value it was on the third previous successful ignition. After ignition is successful, the control sets the ignition temperature at this value for the next 255 calls for heat, after which the control repeats the adaptive algorithm. The control is constantly making adjustments to the ignitor temperature to compensate for changes in the line voltage.

The 80 VAC Silicon Nitride ignitor manufactured by White-Rodgers must be used. These ignitors are specially designed to operate with the 50A66-843's adaptive ignition routine to ensure the most efficient ignitor temperature.

At the end of the ignitor warm-up time, both valves in the gas valve are opened. Flame must be detected within 4 seconds.

If flame is detected, the delay-to-fan-on period begins. After the delay-to-fan-on period ends, the circulator fan is energized at heat speed. If there is an optional electronic air cleaner on the system, the electronic air cleaner and the humidifier are energized. When the thermostat is satisfied, the gas valve is de-energized. After proof of flame loss, the inducer blower remains energized to purge the system for 5 seconds and the delay-to-fan-off period begins. When the purge is complete, the inducer blower and humidifier are de-energized. After the delay-to-fan-off period ends, the circulator fan and electronic air cleaner are de-energized.

If flame is not detected, both valves are de-energized, the ignitor is turned off, and the 50A66-843 control goes into the "retry" sequence. The "retry" sequence provides a 15-second wait following an unsuccessful ignition attempt (flame not detected). After this wait, the ignition sequence is restarted. If this ignition attempt is unsuccessful, three more retries will be made before the control goes into system lockout.

OPERATION

If flame is detected, then lost, the 50A66-843 control will repeat the initial ignition sequence for a total of three "recycles". After three unsuccessful "recycle" attempts, the control will go into system lockout.

If flame is established for more than 10 seconds after ignition, the 50A66-843 controller will clear the ignition attempt (or retry) counter. If flame is lost after 10 seconds, it will restart the ignition sequence. This can occur a maximum of four times before system lockout.

A momentary loss of gas supply, flame blowout, or a shorted or open condition in the flame probe circuit will be sensed within 2 seconds. The gas valve will de-energize and the control will restart the ignition sequence. Recycles will begin and the burner will operate normally if the gas supply returns, or the fault condition is corrected, before the last ignition attempt. Otherwise, the control will go into system lockout.

If the control has gone into system lockout, it may be possible to reset the control by a momentary power interruption of ten seconds or longer. Refer to **PRECAUTIONARY, SYSTEM LOCKOUT, AND DIAGNOSTIC FEATURES**.

COOL MODE

In a typical system, a call for cool is initiated by closing the thermostat contacts. This energizes the 50A66-843 control's cooling sequence. The compressor is energized and the delay-to-fan-on period begins. After the delay-to-fan-on period ends, the circulator fan is energized at cool speed. The electronic air cleaner (optional) is also energized. After the thermostat is satisfied, the compressor is de-energized and the delay-to-fan-off period begins. After the delay-to-fan-off period ends, the circulator fan and electronic air cleaner (optional) are de-energized.

MANUAL FAN ON MODE

If the thermostat fan switch is moved to the ON position, the circulator fan (heat speed) and optional electronic air cleaner are energized. When the fan switch is returned to the AUTO position, the circulator fan and electronic air cleaner (optional) are de-energized.

SYSTEM LOCKOUT AND DIAGNOSTIC FEATURES

SYSTEM LOCKOUT FEATURES

When system lockout occurs, the gas valve is de-energized. The circulator blower is energized at heat speed for some faults, and if flame is sensed, the inducer blower is energized. The diagnostic indicator light will flash or glow continuously to indicate system status. **(System lockout will never override the precautionary features.)**

To reset the control after system lockout, do one of the following:

1. Interrupt the call for heat at the thermostat for at least one second, but less than 20 seconds (if flame is sensed with the gas valve de-energized, interrupting the call for heat at the thermostat will **not** reset the control).

2. Interrupt the 24 VAC power at the control for at least ten seconds. You may also need to reset the flame rollout sensor switch.
3. After one hour in lockout, the control will automatically reset itself.

DIAGNOSTIC FEATURES

The 50A66-843 control continuously monitors its own operation and the operation of the system. If a failure occurs, the DS 1 (red) and DS 2 (green) LEDs will indicate a failure code as shown on next page.

DIAGNOSTIC TABLE

DS 1 (Red)	DS 2 (Green)	Error/Condition	Comments/Troubleshooting
Simultaneous slow flash	Simultaneous slow flash	Normal operation	No fault
Simultaneous fast flash	Simultaneous fast flash	Normal operation with call for heat	Normal operation
Slow flash	On	Open limit switch	Verify continuity through rollout switch circuit
Off	Slow flash	Pressure switch stuck closed/open	Pressure switch stuck closed. Check switch function, verify inducer is turning off. Pressure switch stuck open. Check pressure switch function and tubing. Verify inducer is turning on and pulling sufficient vacuum to engage switch.
Alternate slow flash	Alternate slow flash	External lockout (retries)	Failure to sense flame is often caused by carbon deposits on the flame sensor, a disconnected or shorted flame sensor lead or a poorly grounded furnace. Carbon deposits can be cleaned with emery cloth. Verify sensor is not contacting the burner and is located in a good position to sense flame. Check sensor lead for shorting and verify furnace is grounded properly.
Slow flash	Off	Flame sensed with gas valve de-energized	Verify the gas is operating and shutting down properly. Flame in burner assembly should extinguish promptly at the end of the cycle. Check orifices and gas pressure.
On	Slow flash	Open rollout switch	Verify continuity through rollout switch circuit.
On	On	Module – internal fault condition	Module contacts for gas valve not operating or processor fault. Reset control, if condition persists, replace module.
Slow flash	Fast flash	Low flame sense current	Low flame sense current is often caused by carbon deposits on the flame sensor, a poorly grounded furnace or a mis-aligned flame sense probe. Carbon deposits can be cleaned with emery cloth. Check or improve furnace and module ground. Verify sensor is located in or very near flame as specified by the appliance manufacturer.
Fast flash	Slow flash	Grounding or reversed polarity	Verify the control and furnace are properly grounded. Check and reverse polarity (primary) if incorrect.
Alternate fast flash	Alternate fast flash	Module ignitor contact failure	Fault code indicates the module ignitor contacts are not functioning properly. Replace module.

White-Rodgers is a business
of Emerson Electric Co.

The Emerson logo is a
trademark and service mark
of Emerson Electric Co.

White
Rodgers™

www.white-rodgers.com
www.emersonclimate.com



Free Manuals Download Website

<http://myh66.com>

<http://usermanuals.us>

<http://www.somanuals.com>

<http://www.4manuals.cc>

<http://www.manual-lib.com>

<http://www.404manual.com>

<http://www.luxmanual.com>

<http://aubethermostatmanual.com>

Golf course search by state

<http://golfingnear.com>

Email search by domain

<http://emailbydomain.com>

Auto manuals search

<http://auto.somanuals.com>

TV manuals search

<http://tv.somanuals.com>