

# SmartSwitch Router User Reference Manual

9032578-02

**CABLETRON**  
SYSTEMS



## Notice

Cabletron Systems reserves the right to make changes in specifications and other information contained in this document without prior notice. The reader should in all cases consult Cabletron Systems to determine whether any such changes have been made.

The hardware, firmware, or software described in this manual is subject to change without notice.

IN NO EVENT SHALL CABLETRON SYSTEMS BE LIABLE FOR ANY INCIDENTAL, INDIRECT, SPECIAL, OR CONSEQUENTIAL DAMAGES WHATSOEVER (INCLUDING BUT NOT LIMITED TO LOST PROFITS) ARISING OUT OF OR RELATED TO THIS MANUAL OR THE INFORMATION CONTAINED IN IT, EVEN IF CABLETRON SYSTEMS HAS BEEN ADVISED OF, KNOWN, OR SHOULD HAVE KNOWN, THE POSSIBILITY OF SUCH DAMAGES.

© Copyright November 1998 by:

Cabletron Systems, Inc.  
35 Industrial Way  
Rochester, NH 03867-5005

All Rights Reserved  
Printed in the United States of America

Order Number: 9032578-02

**LANVIEW** is a registered trademark, and **SmartSwitch** is a trademark of Cabletron Systems, Inc.

**CompuServe** is a registered trademark of CompuServe, Inc.

**i960 microprocessor** is a registered trademark of Intel Corp.

**Ethernet** is a trademark of Xerox Corporation.

## FCC Notice

This device complies with Part 15 of the FCC rules. Operation is subject to the following two conditions: (1) this device may not cause harmful interference, and (2) this device must accept any interference received, including interference that may cause undesired operation.

**NOTE:** This equipment has been tested and found to comply with the limits for a Class A digital device, pursuant to Part 15 of the FCC rules. These limits are designed to provide reasonable protection against harmful interference when the equipment is operated in a commercial environment. This equipment uses, generates, and can radiate radio frequency energy and if not installed in accordance with the operator's manual, may cause harmful interference to radio communications. Operation of this equipment in a residential area is likely to cause interference in which case the user will be required to correct the interference at his own expense.

**WARNING:** Changes or modifications made to this device which are not expressly approved by the party responsible for compliance could void the user's authority to operate the equipment.

## VCCI Notice

This is a Class A product based on the standard of the Voluntary Control Council for Interference by Information Technology Equipment (VCCI). If this equipment is used in a domestic environment, radio disturbance may arise. When such trouble occurs, the user may be required to take corrective actions.

この装置は、情報処理装置等電波障害自主規制協議会（VCCI）の基準に基づくクラスA情報技術装置です。この装置を家庭環境で使用すると電波妨害を引き起こすことがあります。この場合には使用者が適切な対策を講ずるよう要求されることがあります。

## DOC Notice

This digital apparatus does not exceed the Class A limits for radio noise emissions from digital apparatus set out in the Radio Interference Regulations of the Canadian Department of Communications.

Le présent appareil numérique n'émet pas de bruits radioélectriques dépassant les limites applicables aux appareils numériques de la class A prescrites dans le Règlement sur le brouillage radioélectrique édicté par le ministère des Communications du Canada.

## DECLARATION OF CONFORMITY ADDENDUM

Application of Council Directive(s):	<b>89/336/EEC 73/23/EEC</b>
Manufacturer's Name:	<b>Cabletron Systems, Inc.</b>
Manufacturer's Address:	<b>35 Industrial Way PO Box 5005 Rochester, NH 03867</b>
European Representative Name:	<b>Mr. J. Solari</b>
European Representative Address:	<b>Cabletron Systems Limited Nexus House, Newbury Business Park London Road, Newbury Berkshire RG13 2PZ, England</b>
Conformance to Directive(s)/Product Standards:	<b>EC Directive 89/336/EEC EC Directive 73/23/EEC EN 55022 EN 50082-1 EN 60950</b>
Equipment Type/Environment:	<b>Networking Equipment, for use in a Commercial or Light Industrial Environment.</b>

We the undersigned, hereby declare, under our sole responsibility, that the equipment packaged with this notice conforms to the above directives.

Manufacturer	Legal Representative in Europe
<u>Mr. Ronald Fotino</u>	<u>Mr. J. Solari</u>
Full Name	Full Name
<u>Principal Compliance Engineer</u>	<u>Managing Director - E.M.E.A.</u>
Title	Title
<u>Rochester, NH, USA</u>	<u>Newbury, Berkshire, England</u>
Location	Location



# Contents

<b>Preface</b> .....	<b>15</b>
About This Manual .....	15
Who Should Read This Manual? .....	15
How to Use This Manual .....	16
Related Documentation.....	16
<b>Chapter 1: SmartSwitch Router Product Overview</b> .....	<b>17</b>
Supported Media (Encapsulation Type).....	19
Supported Routing Protocols .....	19
Configuring the Cabletron SmartSwitch Router .....	20
Understanding the Command Line Interface.....	20
Basic Line Editing Commands .....	20
Access Modes .....	21
User Mode .....	22
Enable Mode .....	22
Configure Mode .....	24
Boot PROM Mode .....	25
Disabling a Function or Feature.....	25
Loading System Images and Configuration Files .....	25
Boot and System Image.....	26
Configuration Files .....	26
Loading System Image Software .....	26
Loading Boot PROM Software.....	27
Activate the Configuration Commands in the Scratchpad.....	28
Copy the Configuration to the Startup Configuration File.....	29
Managing the SSR .....	29
Set SSR Name .....	30
Set SSR Date and Time .....	30
Configure NTP .....	30
Configure the SSR CLI .....	30
Configure SNMP Services .....	31
Configure DNS.....	31
Monitoring Configuration .....	31
<b>Chapter 2: Bridging Configuration Guide</b> .....	<b>33</b>
Bridging Overview.....	33
Spanning Tree (IEEE 802.1d).....	33
Bridging Modes (Flow-Based and Address-Based).....	34
VLAN Overview .....	34

Port-based VLANs.....	35
MAC-address-based VLANs.....	35
Protocol-based VLANs.....	35
Subnet-based VLANs .....	35
Multicast-based VLANs.....	36
Policy-based VLANs .....	36
SSR VLAN Support.....	36
VLANs and the SSR.....	36
Ports, VLANs, and L3 Interfaces .....	37
Access Ports and Trunk Ports (802.1Q support).....	37
Explicit and Implicit VLANs .....	38
Configuring SSR Bridging Functions .....	38
Configure Address-based or Flow-based Bridging .....	38
Configuring Spanning Tree .....	39
Adjust Spanning-Tree Parameters.....	40
Set the Bridge Priority .....	40
Set a Port Priority .....	40
Assign Port Costs .....	41
Adjust Bridge Protocol Data Unit (BPDU) Intervals .....	41
Adjust the Interval between Hello Times .....	41
Define the Forward Delay Interval .....	41
Define the Maximum Age .....	42
Configuring a Port or Protocol based VLAN.....	42
Create a Port or Protocol Based VLAN.....	42
Adding Ports to a VLAN .....	42
Configuring VLAN Trunk Ports.....	42
Configure Bridging for Non-IP/IPX Protocols.....	43
Configure Layer-2 Filters .....	43
Monitor Bridging.....	43
Configuration Examples.....	44
Creating an IP or IPX VLAN .....	44
<b>Chapter 3: IP Routing Configuration Guide .....</b>	<b>45</b>
IP Routing Overview .....	45
IP Routing Protocols .....	46
Unicast Routing Protocols .....	46
Multicast Routing Protocols.....	46
Configuring IP Interfaces and Parameters .....	47
Configure IP Addresses to Ports.....	47
Configure IP Interfaces for a VLAN.....	47
Specify Ethernet Encapsulation Method .....	47
Configure Address Resolution Protocol .....	48
Configure ARP Cache Entries.....	48
Configure Proxy ARP .....	48
Configure DNS Parameters .....	49
Configure IP Services (ICMP) .....	49
Configure IP Helper.....	49
Configure Direct Broadcast .....	50
Monitor IP Parameters.....	50
Configuration Examples.....	51



Assigning IP/IPX Interfaces.....	51
<b>Chapter 4: RIP Configuration Guide .....</b>	<b>53</b>
RIP Overview.....	53
Configure RIP .....	53
Enabling and Disabling RIP .....	54
Configuring RIP Interfaces .....	54
Configure RIP Parameters .....	54
Configure RIP Route Preference.....	55
Configure RIP Route Default-Metric .....	56
Monitoring RIP.....	56
Configuration Example .....	57
<b>Chapter 5: OSPF Configuration Guide.....</b>	<b>59</b>
OSPF Overview .....	59
OSPF Multipath.....	60
Configure OSPF.....	60
Enable OSPF.....	60
Configure OSPF Interface Parameters .....	61
Configure an OSPF Area.....	62
Configure OSPF Area Parameters .....	63
Create Virtual Links.....	63
Configure Autonomous System External (ASE) Link Advertisements .....	64
Configure OSPF over Non-Broadcast Multiple Access.....	64
Monitoring OSPF.....	65
OSPF Configuration Examples.....	66
Exporting All Interface & Static Routes to OSPF .....	67
Export All RIP, Interface & Static Routes to OSPF .....	67
<b>Chapter 6: BGP Configuration Guide.....</b>	<b>71</b>
BGP Overview .....	71
The SSR BGP Implementation.....	72
Basic BGP Tasks.....	72
Setting the Autonomous System Number .....	73
Setting the Router ID .....	73
Configuring a BGP Peer Group .....	73
Adding a BGP Peer .....	75
Starting BGP.....	75
Using AS-Path Regular Expressions .....	75
AS-Path Regular Expression Examples .....	76
Using the AS Path Prepend Feature.....	77
Notes on Using the AS Path Prepend Feature.....	78
BGP Configuration Examples .....	78
BGP Peering Session Example .....	78
IBGP Configuration Example.....	81
IBGP Routing Group Example.....	81
IBGP Internal Group Example.....	84
EBGP Multihop Configuration Example.....	87
Community Attribute Example .....	90

Notes on Using Communities.....	97
Local_Pref Attribute Example.....	97
Notes on Using the Local_Pref Attribute.....	99
Multi-Exit Discriminator Attribute Example.....	99
EBGP Aggregation Example.....	101
Route Reflection Example.....	102
Notes on Using Route Reflection.....	105
<b>Chapter 7: Routing Policy Configuration Guide.....</b>	<b>107</b>
Route Import and Export Policy Overview.....	107
Preference.....	108
Import Policies.....	109
Import-Source.....	109
Route-Filter.....	110
Export Policies.....	110
Export-Destination.....	110
Export-Source.....	110
Route-Filter.....	111
Specifying a Route Filter.....	111
Aggregates and Generates.....	112
Aggregate-Destination.....	113
Aggregate-Source.....	113
Route-Filter.....	114
Authentication.....	114
Authentication Methods.....	114
Authentication Keys and Key Management.....	115
Configure Simple Routing Policies.....	115
Redistributing Static Routes.....	116
Redistributing Directly Attached Networks.....	116
Redistributing RIP into RIP.....	117
Redistributing RIP into OSPF.....	117
Redistributing OSPF to RIP.....	117
Redistributing Aggregate Routes.....	117
Simple Route Redistribution Examples.....	118
Example 1: Redistribution into RIP.....	118
Exporting a Given Static Route to All RIP Interfaces.....	119
Exporting All Static Routes to All RIP Interfaces.....	119
Exporting All Static Routes Except the Default Route to All RIP Interfaces.....	119
Example 2: Redistribution into OSPF.....	119
Exporting All Interface & Static Routes to OSPF.....	120
Export all RIP, Interface & Static Routes to OSPF.....	120
Configure Advanced Routing Policies.....	121
Export Policies.....	121
Creating an Export Destination.....	123
Creating an Export Source.....	123
Import Policies.....	123
Creating an Import Source.....	124
Creating a Route Filter.....	124
Creating an Aggregate Route.....	124

Creating an Aggregate Destination.....	126
Creating an Aggregate Source .....	126
Examples of Import Policies .....	126
Example 1: Importing from RIP.....	126
Importing a Selected Subset of Routes from One RIP Trusted Gateway.....	128
Importing a Selected Subset of Routes from All RIP Peers Accessible Over a Certain Interface .....	129
Example 2: Importing from OSPF .....	129
Importing a Selected Subset of OSPF-ASE Routes .....	132
Examples of Export Policies .....	133
Example 1: Exporting to RIP .....	133
Exporting a Given Static Route to All RIP Interfaces.....	134
Exporting a Given Static Route to a Specific RIP Interface .....	135
Exporting All Static Routes Reachable Over a Given Interface to a Specific RIP-Interface .....	136
Exporting Aggregate-Routes into RIP .....	136
Example 2: Exporting to OSPF.....	138
Exporting All Interface & Static Routes to OSPF .....	139
Exporting All RIP, Interface & Static Routes to OSPF.....	140
<b>Chapter 8: Multicast Routing Configuration Guide .....</b>	<b>143</b>
IP Multicast Overview.....	143
IGMP Overview .....	143
DVMRP Overview .....	144
Configure IGMP .....	145
Configuring IGMP on an IP Interface.....	145
Configure IGMP Query Interval.....	145
Configure IGMP Response Wait Time.....	145
Configure Per-Interface Control of IGMP Membership.....	146
Configure DVMRP .....	146
Starting and Stopping DVMRP.....	146
Configure DVMRP on an Interface .....	147
Configure DVMRP Parameters.....	147
Configure the DVMRP Routing Metric .....	147
Configure DVMRP TTL & Scope.....	148
Configure a DVMRP Tunnel .....	148
Monitor IGMP & DVMRP.....	149
Configuration Examples .....	150
<b>Chapter 9: IPX Routing Configuration Guide.....</b>	<b>151</b>
IPX Routing Overview .....	151
RIP (Routing Information Protocol).....	151
SAP (Service Advertising Protocol) .....	152
Configuring IPX RIP & SAP .....	153
IPX RIP.....	153
IPX SAP .....	153
Creating IPX Interfaces .....	153

IPX Addresses.....	153
Configuring IPX Interfaces and Parameters.....	154
Configure IPX Addresses to Ports.....	154
Configure IPX Interfaces for a VLAN.....	154
Specify IPX Encapsulation Method.....	154
Configure IPX Routing.....	155
Enable IPX RIP.....	155
Enable SAP.....	155
Configure Static Routes.....	155
Configure Static SAP Table Entries.....	156
Control Access to IPX Networks.....	156
Create an IPX Access Control List.....	156
Create an IPX Type 20 Access Control List.....	157
Create an IPX SAP Access Control List.....	157
Create an IPX GNS Access Control List.....	157
Create an IPX RIP Access Control List.....	158
Monitor an IPX Network.....	158
Configuration Examples.....	158

**Chapter 10: Security Configuration Guide ..... 161**

Security Overview.....	161
Configuring SSR Access Security.....	162
Configure RADIUS.....	162
Monitor RADIUS.....	162
Configure TACACS.....	162
Monitor TACACS.....	163
Configure TACACS Plus.....	163
Monitor TACACS Plus.....	163
Configure Passwords.....	164
Layer-2 Security Filters.....	164
Configuring Layer-2 Address Filters.....	165
Configuring Layer-2 Port-to-Address Lock Filters.....	165
Configuring Layer-2 Static Entry Filters.....	166
Configuring Layer-2 Secure Port Filters.....	166
Monitor Layer-2 Security Filters.....	167
Layer-2 Filter Examples.....	168
Example 1: Address Filters.....	168
Static Entries Example.....	168
Port-to-Address Lock Examples.....	169
Example 2 : Secure Ports.....	169
Layer-3 Access Control Lists (ACLs).....	170
Layer-3 & Layer-4 Traffic Filters (Access Control List).....	170
Anatomy of an ACL Rule.....	170
Ordering of ACL Rules.....	171
Implicit Deny Rule.....	172
Applying ACLs to Interfaces.....	173
Applying ACLs to Services.....	174
ACL Logging.....	174
Maintaining ACLs Offline Using TFTP or RCP.....	175
Maintaining ACLs Using the ACL Editor.....	176

Configure ACL .....	176
Defining an IP ACL .....	176
Defining an IPX ACL.....	177
Applying an ACL to an Interface .....	177
Applying an ACL to a Service .....	177
Edit an ACL with the ACL Editor .....	177
Monitoring Access Control Lists .....	177
<b>Chapter 11: QoS Configuration Guide .....</b>	<b>179</b>
QoS & Layer-2/Layer-3/Layer-4 Flow Overview .....	179
Layer-2, Layer-3 & Layer-4 Flow Specification .....	179
Precedence for Layer-3 Flows .....	180
SSR Queuing Policies.....	180
Configure Layer-2 QoS.....	181
Configuring Layer-3 & Layer-4 QoS .....	181
Configuring IP QoS Policies .....	182
Setting an IP QoS Policy .....	182
Specifying Precedence for an IP QoS Policy .....	182
Configuring IPX QoS Policies .....	182
Setting an IPX QoS Policy .....	183
Specifying Precedence for an IPX QoS Policy .....	183
Configuring SSR Queueing Policy.....	183
Allocating Bandwidth for a Weighted-Fair Queuing Policy .....	183
Monitoring QoS.....	184
<b>Chapter 12: Performance Monitoring Guide .....</b>	<b>185</b>
Performance Monitoring Overview .....	185
Configuring the SSR for Port Mirroring .....	187
<b>Chapter 13: Hot Swapping</b>	
<b>Line Cards and Control Modules.....</b>	<b>189</b>
Hot Swapping Overview .....	189
Hot Swapping Line Cards .....	189
Deactivating the Line Card.....	190
Removing the Line Card.....	190
Installing a New Line Card .....	191
Hot Swapping One Type of Line Card With Another.....	191
Hot Swapping a Secondary Control Module.....	191
Deactivating the Control Module.....	192
Removing the Control Module .....	192
Installing the Control Module.....	193
Hot Swapping a Switching Fabric Module (SSR 8600 only).....	193
<b>Chapter 14: VRRP Configuration Guide.....</b>	<b>195</b>
VRRP Overview .....	195
Configuring VRRP .....	195
Basic VRRP Configuration.....	196
Configuration of Router R1 .....	196

Configuration for Router R2.....	197
Symmetrical Configuration .....	197
Configuration of Router R1 .....	198
Configuration of Router R2 .....	199
Multi-Backup Configuration .....	199
Configuration of Router R1 .....	201
Configuration of Router R2 .....	202
Configuration of Router R3 .....	203
Additional Configuration .....	203
Setting the Backup Priority.....	204
Setting the Advertisement Interval .....	204
Setting Pre-empt Mode .....	204
Setting an Authentication Key .....	205
Monitoring VRRP .....	205
ip-redundancy trace.....	205
ip-redundancy show .....	206
VRRP Configuration Notes.....	206

# Preface

## About This Manual

This manual provides detailed information and procedures for configuring the SmartSwitch Router SSR software. If you have not yet installed the SSR, use the instructions in the *SmartSwitch Router Getting Started Guide* to install the chassis and perform basic setup tasks, then return to this manual for more detailed configuration information.

## Who Should Read This Manual?

Read this manual if you are a network administrator responsible for configuring and monitoring the SSR.

## How to Use This Manual

If You Want To	See
Read overview information	<a href="#">Chapter 1 on page 17</a>
Configure bridging	<a href="#">Chapter 2 on page 33</a>
Configure IP interfaces and global routing parameters	<a href="#">Chapter 3 on page 45</a>
Configure RIP routing	<a href="#">Chapter 4 on page 53</a>
Configure OSPF routing	<a href="#">Chapter 5 on page 59</a>
Configure BGP routing	<a href="#">Chapter 6 on page 71</a>
Configure routing policies	<a href="#">Chapter 7 on page 107</a>
Configure IP multicast routing	<a href="#">Chapter 8 on page 143</a>
Configure IPX routing	<a href="#">Chapter 9 on page 151</a>
Configure security	<a href="#">Chapter 10 on page 161</a>
Configure QoS (Quality of Service) parameters	<a href="#">Chapter 11 on page 179</a>
Monitor performance	<a href="#">Chapter 12 on page 185</a>
Hot swap line cards and Control Modules	<a href="#">Chapter 13 on page 189</a>
Configure VRRP	<a href="#">Chapter 14 on page 195</a>

## Related Documentation

The Cabletron Systems documentation set includes the following items. Refer to these other documents to learn more about your product.

For Information About	See the
Installing and setting up the SSR	<i>SmartSwitch Router Getting Started Guide</i>
Managing the SSR using Cabletron Systems' element management application	<i>CoreWatch User's Manual</i> and the CoreWatch online help
The complete syntax for all CLI commands	<i>SmartSwitch Router Command Line Interface Reference Manual</i>
System messages and SNMP traps	<i>SmartSwitch Router Error Message Reference Manual</i>



# Chapter 1

## SmartSwitch Router Product Overview

The SmartSwitch Router (SSR) provides non-blocking, wire-speed Layer-2 (switching), Layer-3 (routing) and Layer-4 (application) switching. The hardware provides wire-speed performance regardless of the performance monitoring, filtering, and Quality of Service (QoS) features enabled by the software. You do not need to accept performance compromises to run QoS or access control lists (ACLs).

The following table lists the basic hardware and software specifications for the SSR:

**Table 1. SSR Hardware and software specifications**

Feature	Specification
Throughput	<ul style="list-style-type: none"> <li>• 16-Gbps non-blocking switching fabric</li> <li>• 15 million packets-per-second routing throughput</li> </ul>
Capacity	<ul style="list-style-type: none"> <li>• Up to 250,000 routes</li> <li>• Up to 2,000,000 Layer-4 application flows</li> <li>• 400,000 Layer-2 MAC addresses</li> <li>• 4,096 Virtual LANs (VLANs)</li> <li>• 20,000 Layer-2 security and access-control filters</li> <li>• 3MB input/output buffering per Gigabit port</li> <li>• 1MB input/output buffering per 10/100 port</li> </ul>
Routing protocols	<ul style="list-style-type: none"> <li>• IP: RIPv1/v2, OSPF, BGP 2,3,4</li> <li>• IPX: RIP, SAP</li> <li>• Multicast: IGMP, DVMRP</li> </ul>
Bridging and VLAN protocols	<ul style="list-style-type: none"> <li>• 802.1d Spanning Tree</li> <li>• 802.1Q (VLAN trunking)</li> </ul>
Media Interface protocols	<ul style="list-style-type: none"> <li>• 802.3 (10Base-T)</li> <li>• 802.3u (100Base-TX, 100BASE-FX)</li> <li>• 802.3x (1000Base-SX, 1000Base-LX)</li> <li>• 802.3z (1000Base-SX, 1000Base-LX)</li> </ul>
Quality of Service (QoS)	<ul style="list-style-type: none"> <li>• Layer-2 prioritization (802.1p)</li> <li>• Layer-3 source-destination flows</li> <li>• Layer-4 source-destination flows</li> <li>• Layer-4 application flows</li> </ul>
RMON	<ul style="list-style-type: none"> <li>• RMONv1/v2 for each port</li> </ul>
Management	<ul style="list-style-type: none"> <li>• SNMP</li> <li>• CoreWatch Element Manager (GUI)</li> <li>• Emacs-like Command Line Interface (CLI)</li> </ul>

**Table 1. SSR Hardware and software specifications (continued)**

Feature	Specification
Port mirroring	<ul style="list-style-type: none"> <li>Traffic to Control Module</li> <li>Traffic from specific ports</li> <li>Traffic to specific chassis slots (line cards)</li> </ul>
Hot swapping	<ul style="list-style-type: none"> <li>Power supply (when redundant supply is installed and online)</li> </ul>
Load balancing/sharing	<ul style="list-style-type: none"> <li>Cabletron Systems SMARTtrunk support</li> </ul>
Redundancy	<ul style="list-style-type: none"> <li>Redundant and hot-swappable power supplies</li> <li>Virtual Router Redundancy Protocol (VRRP)</li> </ul>

## Supported Media (Encapsulation Type)

The SSR supports the following industry-standard networking media:

- IP: IEEE 802.3 SNAP and Ethernet Type II
- IPX: IEEE 802.3 SNAP, Ethernet Type II, IPX 802.3, 802.2
- 802.1Q VLAN Encapsulation

## Supported Routing Protocols

The SSR supports many routing protocols based on open standards. The SSR can receive and forward packets concurrently from any combination of the following:

- Interior gateway protocols:
  - Open Shortest Path First (OSPF) Version 2
  - Routing Information Protocol (RIP) Version 1, 2

[Chapter 3: “IP Routing Configuration Guide” on page 45](#) describes these protocols in detail.

- Exterior gateway protocol:
  - Border Gateway Protocol (BGP) Version 2,3,4

[Chapter 6: “BGP Configuration Guide” on page 71](#) describes this protocol in detail.

- Novell IPX routing protocols:
  - Routing Information Protocol (RIP)

- Service Advertising Protocol (SAP)

[Chapter 9: “IPX Routing Configuration Guide” on page 151](#) describes these protocols in detail.

## Configuring the Cabletron SmartSwitch Router

The SSR provides a command line interface (CLI) that allows you to configure and manage the SSR. The CLI has several command modes, each of which provides a group of related commands that you can use to configure the SSR and display its status. Some commands are available to all users; others can be executed only after the user enters an “Enable” password.

You use the CLI to configure ports, IP/IPX interfaces, routing, switching, security filters and Quality of Service (QoS) policies.

## Understanding the Command Line Interface

The SSR Command Line Interface (CLI) provides access to several different command modes. Each command mode provides a group of related commands. This chapter describes how to access and list the commands available in each command mode and explains the primary uses for each command mode. This chapter also describes the other features of the user interface.

SSR commands can be entered at a terminal connected to the access server or router using the command line interface (CLI). The SSR can also be configured using the CoreWatch Java-based management application. Using CoreWatch is described in the *CoreWatch User’s Guide*.

## Basic Line Editing Commands

The CLI supports EMACs-like line editing commands. The following table lists some commonly used commands.

**Table 2. Common CLI key commands**

Key Sequence	Command
Ctrl+A	Move cursor to beginning of line
Ctrl+B	Move cursor back one character
Ctrl+D	Delete character
Ctrl+E	Move cursor to end of line

**Table 2. Common CLI key commands (continued)**

Key Sequence	Command
Ctrl+F	Move cursor forward one character
Ctrl+N	Scroll to next command in command history (use the <b>cli show history</b> command to display the history)
Ctrl+P	Scroll to previous command in command history
Ctrl+U	Erase entire line
Ctrl+X	Erase from cursor to end of line
Ctrl+Z	Exit current access mode to previous access mode

## Access Modes

The SSR CLI has four access modes.

- **User** – Allows you to display basic information and use basic utilities such as ping but does not allow you to display SNMP, filter and access control list information or make other configuration changes. You are in User mode when the command prompt ends with the > character:
- **Enable** – Allows you to display SNMP, filter, and access control information as well as all the information you can display in User mode. To enter Enable mode, enter the **enable** command, then supply the password when prompted. When you are in Enable mode, the command prompt ends with the # character:
- **Configure** – Allows you to make configuration changes. To enter Configure mode, first enter Enable mode (**enable** command), then enter the **configure** command from the Enable command prompt. When you are in Configure mode, the command prompt ends with (conf ig).
- **Boot** – This mode appears when the SSR the external flash card or the system image is not found during bootup. You should enter the **reboot** command to reset the SSR. If the SSR still fails to bootup, please call Cabletron Technical Support.

**Note:** The command prompt will show the name of the SmartSwitch Router in front of the mode character(s). The default name is “ssr”.

When you are in Configure or Enable mode, enter the **exit** command or press Ctrl+Z to exit to the previous access mode.

**Note:** When you exit Configure mode, the CLI will ask you whether you want to activate the configuration commands you have issued. If you enter Y (Yes), the configuration commands you issued are placed into effect and the SmartSwitch Router’s configuration is changed accordingly. However, the changes are not written to the Startup configuration file in the Control Module’s boot flash and therefore are not reinstated after a reboot.

## User Mode

After you log in to the SSR, you are automatically in User mode. The User commands available are a subset of those available in Enable mode. In general, the User commands allow you to display basic information and use basic utilities such as ping information.

To list the User commands, enter:

List the User commands.	?
-------------------------	---

The User mode command prompt consists of the SSR name followed by the angle bracket (>):

ssr>
------

The default name is SSR unless it has been changed during initial configuration using the system set name command. Refer to the *SmartSwitch Router Command Line Interface Reference Manual* for information on the system facility.

To list the commands available in User mode, enter a question mark (?) as shown in the following example:

ssr> ?	
aging	- Show L2 and L3 Aging information
cli	- Modify the command line interface behavior
dvmrp	- Show DVMRP related parameters
enable	- Enable privileged user mode
exit	- Exit current mode
file	- File manipulation commands
igmp	- Show IGMP related parameters
ipx	- Show IPX related parameters
l2-tables	- Show L2 Tables information
logout	- Log off the system
multicast	- Configure Multicast related parameters
ping	- Ping utility
statistics	- Show or clear SSR statistics
stp	- Show STP status
tracert	- Traceroute utility
vlan	- Show VLAN-related parameters

## Enable Mode

Enable mode provides more facilities than User mode. You can display critical features within Enable mode including router configuration, access control lists and SNMP statistics. To enter Enable mode, enter the **enable** command, then supply the password when prompted.

To list the Enable commands, enter:

List the Enable commands.	?
---------------------------	---

The Enable mode command prompt consists of the SSR name followed by the pound sign(#):

ssr#
------

To list the commands available in Enable mode, enter a question mark (?) as shown in the following example:

ssr# ?	
acl	- Show L3 Access Control List
aging	- Show L2 and L3 Aging information
arp	- Show or modify ARP entries
cli	- Modify the command line interface behavior
configure	- Enter Configuration Mode
copy	- Copy configuration database
dvmrp	- Show DVMRP related parameters
enable	- Enable privileged user mode
exit	- Exit current mode
file	- File manipulation commands
filters	- Show L2 security filters
http	- Show http parameters
igmp	- Show IGMP related parameters
interface	- Show interface related parameters
ip	- Show IP related parameters
ip-router	- Show unicast IP Routing related parameters
ipx	- Show IPX related parameters
l2-tables	- Show L2 Tables information
logout	- Log off the system
mtrace	- Multicast Traceroute utility
multicast	- Configure Multicast related parameters
ospf	- Show/Monitor Open Shortest Path First Protocol (OSPF).
ping	- Ping utility
port	- Show or change Port parameters
qos	- Show Quality of Service parameters
reboot	- Reboot the system
rip	- Show/Query Routing Information Protocol(RIP) tables
snmp	- Show SNMP related parameters.
statistics	- Show or clear SSR statistics
stp	- Show STP status
system	- Show system-wide parameters
tacacs	- Show TACACS related parameters
traceroute	- Traceroute utility
vlan	- Show VLAN-related parameters

To exit Enable mode and return to User mode, use one of the following commands:

Exit Enable mode.	<b>exit</b>
	Ctrl+Z

## Configure Mode

Configure mode provides the capabilities to configure all features and functions on the SSR. You can configure features and functions within Configure mode including router configuration, access control lists and spanning tree.

To list the Configure commands, enter:

List the Configure commands.	<b>?</b>
------------------------------	----------

The Configure mode command prompt consists of the SSR name followed by the pound sign (#):

```
ssr(config)#
```

To list the commands available in Configure mode, enter a question mark (?) as shown in the following example:

```
ssr(config)# ?
acl                - Configure L3 Access Control List
acl-edit           - Edit an ACL in the ACL Editor
aging              - Configure L2 and L3 Aging
arp                - Configure ARP entries
bgp                - Configure Border Gateway Protocol (BGP)
cli                - Modify the command line interface behavior
dvmrp              - Configure DVMRP related parameters
exit               - Exit current mode
filters            - Configure L2 security filters
http               - Configure SNMP related parameters.
igmp               - Configure IGMP related parameters
interface          - Configure interface related parameters
ip                 - Configure IP related parameters
ip-router          - Configure Unicast Routing Protocol related
                    parameters
ipx                - Configure IPX related parameters
ospf               - Configure Open Shortest Path Protocol (OSPF)
port               - Configure Port parameters
qos                - Configure Quality of Service parameters
rip                - Configure Routing Information Protocol (RIP)
snmp               - Configure SNMP related parameters.
stp                - Configure STP parameters
system            - Configure system-wide parameters
```



tacacs	- Configure TACACS related parameters
vlan	- Configure VLAN-related parameters
Special configuration mode commands:	
erase	- Erase configuration information
negate	- Negate a command or a group of commands using line numbers
no	- Negate matching commands
save	- Save configuration information
search	- Look up a command in configuration
show	- Show configuration commands

To exit Configure mode and return to Enable mode, use one of the following commands:

Exit Configure mode.	<b>exit</b>
	Ctrl+Z

## Boot PROM Mode

If your SSR does not find a valid system image on the external PCMCIA flash, the system might enter programmable read-only memory (PROM) mode. You should then reboot the SSR at the boot PROM to restart the system. If the system fails to reboot successfully, please call Cabletron Systems Technical Support to resolve the problem.

To reboot the SSR from the ROM monitor mode, enter the following command.

Reboot in Boot PROM mode.	<b>reboot</b>
---------------------------	---------------

## Disabling a Function or Feature

The CLI provides for an implicit negate. This allows for the “disabling” of a feature or function which has been “enabled”. Use the **negate** command on a specific line of the active configuration to “disable” a feature or function which has been enabled. For example, Spanning Tree Protocol is disabled by default. If after enabling Spanning Tree Protocol on the SmartSwitch Router, you want to disable STP, you must specify the **negate** command on the line of the active configuration containing the **stp enable** command.

## Loading System Images and Configuration Files

The SSR contains an internal flash on the Control Module and an external PC flash. The internal flash contains the SSR boot image and user defined configuration files. An external PC flash contains the system image executed by the Control module. When an

SSR boots, the boot image is executed first, followed by the system image and finishing with a configuration file.

## Boot and System Image

Only one boot image exists on the internal flash of the SSR Control Module. Multiple system images can be stored on the external PC flash.

## Configuration Files

The SSR uses three special configuration files:

- **Active** – The commands from the Startup configuration file and any configuration commands that you have made active from the scratchpad (see below).



**Caution:** The active configuration remains in effect only during the current power cycle. If you power down or reboot the SSR without saving the active configuration changes to the Startup configuration file, the changes are lost.

- **Startup** – The configuration file that the SSR uses to configure itself when the system is powered on.
- **Scratchpad** – The configuration commands you have entered during a management session. These commands do not become active until you explicitly activate them. Because some commands depend on other commands for successful execution, the SSR scratchpad simplifies system configuration by allowing you to enter configuration commands in any order, even when dependencies exist. When you activate the commands in the scratchpad, the SSR sorts out the dependencies and executes the command in the proper sequence.

## Loading System Image Software

By default, the SSR boots using the system image software installed on the Control Module's PCMCIA flash card. To upgrade the system software and boot using the upgraded image, use the following procedure.

1. Display the current boot settings by entering the **system show version** command:

Here is an example:

```
ctron-ssr-1# system show version
Software Information
  Software Version   : 1.0
  Copyright          : Copyright (c) 1996-1998 Cabletron Systems Inc.
  Image Information  : Version 1.0 built on Fri Mar 20 19:28:49 1998
  Image Boot Location: file:/pc-flash/boot/ssr8/
```

**Note:** In this example, the location “pc-flash” indicates that the SSR is set to use the factory-installed software on the flash card.

2. Copy the software upgrade you want to install onto a TFTP server that the SSR can access. (Use the **ping** command to verify that the SSR can reach the TFTP server.)
3. Use the **system image add** command to copy the software upgrade onto the PCMCIA flash card in the Control Module.

Here is an example:

```
ctron-ssr-1# system image add 10.50.11.12 ssr8000
Downloading image 'ssr8000' from host '10.50.11.12'
to local image ssr8000 (takes about 3 minutes)
kernel: 100%
Image checksum validated.
Image added.
```

4. Enter the **system image list** command to list the images on the PCMCIA flash card and verify that the new image is on the card:

Here is an example:

```
ctron-ssr-1# system image list
Images currently available:
ssr8-1.0
```

5. Use the **system image choose** command to select the image file the SSR will use the next time you reboot the switch.

Here is an example:

```
ctron-ssr-1# system image choose ssr8000_10A9
Making image ssr8-1.0 the active image for next reboot
```

6. Enter the **system image list** command to verify the change.

**Note:** You do not need to activate this change.

## Loading Boot PROM Software

The SSR boots using the boot PROM software installed on the Control Module’s internal memory. To upgrade the boot PROM software and boot using the upgraded image, use the following procedure.

1. Display the current boot settings by entering the **system show version** command:

Here is an example:

```
ctron-ssr-1# system show version
Software Information
Software Version   : 1.0
Copyright          : Copyright (c) 1996-1998 Cabletron Systems Inc.
Image Information  : Version 1.0.B.13 built on Wed Mar 25 22:49:07 1998
Image Boot Location: file:/pc-flash/boot/ssr8/
Boot Prom Version  : prom-1.0
```

In this example, the location “pc-flash” indicates that the SSR is set to use the factory-installed software on the flash card.

2. Copy the software upgrade you want to install onto a TFTP server that the SSR can access. (Use the **ping** command to verify that the SSR can reach the TFTP server.)
3. Use the **system promimage upgrade** command to copy the boot PROM upgrade onto the internal memory in the Control Module.

Here is an example:

```
ctron-ssr-1# system promimage upgrade 10.50.11.12 prom2
Downloading image 'prom2' from host '10.50.11.12'
  to local image prom2 (takes about 3 minutes)
kernel: 100%
Image checksum validated.
Image added.
```

4. Enter the **system show version** command to verify that the new boot PROM software is on the internal memory of the Control Module:

## Activate the Configuration Commands in the Scratchpad

The configuration commands you have entered using procedures in this chapter are in the Scratchpad but have not yet been activated. Use the following procedure to activate the configuration commands in the scratchpad.

1. If you have not already done so, enter the **enable** command to enter Enable mode in the CLI.
2. If you have not already done so, enter the **configure** command to enter Configure mode in the CLI.
3. Enter the following command:

```
save active
```

- The CLI displays the following message:

```
Do you want to make the changes Active? [y]
```

- Enter **yes** or **y** to activate the changes.

**Note:** If you exit Configure mode (by entering the exit command or pressing Ctrl+Z), the CLI will ask you whether you want to make the changes in the scratchpad active.

## Copy the Configuration to the Startup Configuration File

After you save the configuration commands in the scratchpad, the Control Module executes the commands and makes the corresponding configuration changes to the SSR. However, if you power down or reboot the SSR, the new changes are lost. Use the following procedure to save the changes into the Startup configuration file so that the SSR reinstates the changes when you reboot the software.

- Ensure that you are in the Enable mode by entering the **enable** command.
- Enter the following command to copy the configuration changes in the Active configuration to the Startup configuration:

```
copy active to startup
```

- When the CLI displays the following message, enter **yes** or **y** to save the changes.

```
Are you sure you want to overwrite the Startup configuration? [n]
```

**Note:** You also can save active changes to the Startup configuration file from within Configure mode by entering the **save startup** command:

The new configuration changes are added to the Startup configuration file stored in the Control Module's boot flash.

## Managing the SSR

The SSR contains numerous system facilities for system management. You can perform configuration management tasks on the SSR including:

- Setting the SSR name
- Setting the SSR date and time
- Configuring the CLI
- Configuring SNMP services

## Set SSR Name

The SSR name is set to **ssr** by default. You may customize the name for the SSR by entering the following command in Configure mode:.

Set the SSR name.	<b>system set name</b> <system-name>
-------------------	--------------------------------------

## Set SSR Date and Time

The SSR system time can keep track of time as entered by the user or via NTP. To configure the SSR date and time manually, enter the following command in Enable mode:

Set SSR date and time.	<b>system set date year</b> <year> <b>month</b> <month> <b>day</b> <day> <b>hour</b> <hour> <b>min</b> <min> <b>second</b> <sec>
------------------------	---

## Configure NTP

You can use the **ntp set server** command to instruct the SSR's NTP client to periodically synchronize its clock. By default, the SSR specifies an NTPv3 client that sends a synchronization packet to the server every 60 minutes. This means the SSR will attempt to set its own clock against the server once every hour. The synchronization interval as well as the NTP version number can be changed.

**Note:** To ensure that NTP has the correct time, you need to specify the time zone, as well. You can set the time zone by using the **system set timezone** command. When specifying daylight saving time, you'll need to use the **system set daylight-saving** command.

To configure the SSR's NTP client to synchronize its clock, enter the following command in Configure mode:

Instruct SSR's NTP server to periodically synchronize clock	<b>ntp set server</b> <host> [ <b>interval</b> <minutes>] <b>[source</b> <ipaddr>] [ <b>version</b> <num>]
---	---

## Configure the SSR CLI

You can customize the CLI display format to a desired line length or row count. To configure the CLI terminal display, enter the following command in Enable mode:

Configure the CLI terminal display.	<b>cli set terminal rows</b> <num> <b>columns</b> <num>
-------------------------------------	--

## Configure SNMP Services

The SSR accepts SNMP sets and gets from an SNMP manager. You can configure SSR SNMP parameters including community strings and trap server target addresses.

To configure the SSR SNMP community string, enter the following command in Configure mode:

Configure the SNMP community string.	<b>snmp set community</b> <community-name> <b>privilege read read-write</b>
--------------------------------------	--

To configure the SNMP trap server target address, enter the following command in Configure mode:

Configure the SNMP trap server target address.	<b>snmp set target</b> <IP-addr> <b>community</b> <community-name> [ <b>status</b> <b>enable disable</b> ]
--	--

## Configure DNS

The SSR allows you to configure up to three Domain Name Service (DNS) servers.

To configure the DNS, the following command in Configure mode.

Configure DNS.	<b>system set dns server</b> <IPaddr>[ <IPaddr>[ <IPaddr>]] <b>domain</b> <name>
----------------	---

## Monitoring Configuration

The SSR provides many commands for displaying configuration information. After you add configuration items and commit them to the active configuration, you can display them using the following commands.

Task	Command
Display history buffer.	<b>cli show history</b>
Show terminal settings.	<b>cli show terminal</b>
Show all accesses to the SNMP agent.	<b>snmp show access</b>
Show all SNMP information.	<b>snmp show all</b>
Show chassis ID.	<b>snmp show chassis-id</b>

Task	Command
Show the SNMP community strings.	<b>snmp show community</b>
Show SNMP related statistics.	<b>snmp show statistics</b>
Show trap target related configuration.	<b>snmp show trap</b>
Show the active configuration of the system.	<b>system show active-config</b>
Show the contents of the boot log file, which contains all the system messages generated during bootup.	<b>system show bootlog</b>
Show the most recent Syslog messages kept in the local syslog message buffer.	<b>system show syslog buffer</b>
<i>Show the contact information (administrator name, phone number, and so on).</i>	<b>system show contact</b>
Show the SSR date and time.	<b>system show date</b>
Show the IP addresses and domain names for DNS servers.	<b>system show dns</b>
Show SSR hardware information.	<b>system show hardware</b>
Show SSR location.	<b>system show location</b>
Show SSR name.	<b>system show name</b>
Show the type of Power-On Self Test (POST) that should be performed.	<b>system show poweron-selftest-mode</b>
Show the configuration changes in the scratchpad. These changes have not yet been activated.	<b>system show scratchpad</b>
Show the startup configuration for the next reboot.	<b>system show startup-config</b>
Show the IP address of the SYSLOG server and the level of messages the SSR sends to the server.	<b>system show syslog</b>
Lists the last five Telnet connections to the SSR.	<b>system show telnet-access</b>
Show the default terminal settings (number of rows, number of columns, and baud rate).	<b>system show terminal</b>
Show SSR uptime.	<b>system show uptime</b>
Show the software version running on the SSR.	<b>system show version</b>



# Chapter 2

## Bridging Configuration Guide

### Bridging Overview

The SmartSwitch Router provides the following bridging functions:

- Complies with the IEEE 802.1d standard
- Complies with the IGMP multicast bridging standard
- Provides wire-speed address-based bridging or flow-based bridging
- Provides the ability to logically segment a transparently bridged network into virtual local-area networks (VLANs) based on physical ports or protocol (IP or IPX or bridged protocols like Appletalk)
- Allows frame filtering based on MAC address for bridged and multicast traffic
- Provides integrated routing and bridging, which supports bridging of intra-VLAN traffic and routing of inter-VLAN traffic

### Spanning Tree (IEEE 802.1d)

Spanning tree (IEEE 802.1d) allows bridges to dynamically discover a subset of the topology that is loop-free. In addition, the loop-free tree that is discovered contains paths to every LAN segment.

**Note:** WAN interfaces on the SSR do not currently support Spanning Tree operations. However, future implementations of WAN for the SSR family of routers will support Spanning Tree.

## Bridging Modes (Flow-Based and Address-Based)

The SSR provides the following types of wire-speed bridging:

**Address-based bridging** - The SSR performs this type of bridging by looking up the destination address in an L2 lookup table on the line card that receives the bridge packet from the network. The L2 lookup table indicates the exit port(s) for the bridged packet. If the packet is addressed to the SSR's own MAC address, the packet is routed rather than bridged.

**Flow-based bridging** - The SSR performs this type of bridging by looking up an entry in the L2 lookup table containing both the source and destination addresses of the received packet in order to determine how the packet is to be handled.

The SSR ports perform address-based bridging by default but can be configured to perform flow-based bridging instead, on a per-port basis. A port cannot be configured to perform both types of bridging at the same time.

The SSR performance is equivalent when performing flow-based bridging or address-based bridging. However, address-based bridging is more efficient because it requires fewer table entries while flow-based bridging provides tighter management and control over bridged traffic.

## VLAN Overview

Virtual LANs (VLANs) are a means of dividing a physical network into several logical (virtual) LANs. The division can be done on the basis of various criteria, giving rise to different types of VLANs. For example, the simplest type of VLAN is the port-based VLAN. Port-based VLANs divide a network into a number of VLANs by assigning a VLAN to each port of a switching device. Then, any traffic received on a given port of a switch *belongs* to the VLAN associated with that port.

VLANs are primarily used for broadcast containment. A layer-2 (L2) broadcast frame is normally transmitted all over a bridged network. By dividing the network into VLANs, the *range* of a broadcast is limited, i.e., the broadcast frame is transmitted only to the VLAN to which it belongs. This reduces the broadcast traffic on a network by an appreciable factor.

The type of VLAN depends upon one criterion: how a received frame is classified as belonging to a particular VLAN. VLANs can be categorized into the following types:

- Port based

- MAC address based
- Protocol based
- Subnet based
- Multicast based
- Policy based

Detailed information about these types of VLANs is beyond the scope of this manual. Each type of VLAN is briefly explained in the following subsections.

### **Port-based VLANs**

Ports of L2 devices (switches, bridges) are assigned to VLANs. Any traffic received by a port is classified as belonging to the VLAN to which the port belongs. For example, if ports 1, 2, and 3 belong to the VLAN named “Marketing”, then a broadcast frame received by port 1 is transmitted on ports 2 and 3. It is not transmitted on any other port.

### **MAC-address-based VLANs**

In this type of VLAN, each switch (or a central VLAN information server) keeps track of all MAC addresses in a network and maps them to VLANs based on information configured by the network administrator. When a frame is received at a port, its destination MAC address is looked up in the VLAN database, which returns the VLAN to which this frame belongs.

This type of VLAN is powerful in the sense that network devices such as printers and workstations can be moved anywhere in the network without the need for network reconfiguration. However, the administration is intensive because all MAC addresses on the network need to be known and configured.

### **Protocol-based VLANs**

Protocol-based VLANs divide the physical network into logical VLANs based on protocol. When a frame is received at a port, its VLAN is determined by the protocol of the packet. For example, there could be separate VLANs for IP, IPX and Appletalk. An IP broadcast frame will only be sent to all ports in the IP VLAN.

### **Subnet-based VLANs**

Subnet-based VLANs are a subset of protocol based VLANs and determine the VLAN of a frame based on the subnet to which the frame belongs. To do this, the switch must look into the network layer header of the incoming frame. This type of VLAN behaves similar to a router by segregating different subnets into different broadcast domains.

### Multicast-based VLANs

Multicast-based VLANs are created dynamically for multicast groups. Typically, each multicast group corresponds to a different VLAN. This ensures that multicast frames are received only by those ports that are connected to members of the appropriate multicast group.

### Policy-based VLANs

Policy-based VLANs are the most general definition of VLANs. Each incoming (untagged) frame is looked up in a policy database, which determines the VLAN to which the frame belongs. For example, you could set up a policy which creates a special VLAN for all email traffic between the management officers of a company, so that this traffic will not be seen anywhere else.

## SSR VLAN Support

The SSR supports:

- Port-based VLANs
- Protocol-based VLANs
- Subnet-based VLANs

When using the SSR as an L2 bridge/switch, use the port-based and protocol-based VLAN types. When using the SSR as a combined switch and router, use the subnet-based VLANs in addition to port-based and protocol-based VLANs. It is not necessary to remember the types of VLANs in order to configure the SSR, as seen in the section on configuring the SSR.

### VLANs and the SSR

VLANs are an integral part of the SSR family of switching routers. The SSR switching routers can function as layer-2 (L2) switches as well as fully-functional layer-3 (L3) routers. Hence they can be viewed as a switch and a router in one box. To provide maximum performance and functionality, the L2 and L3 aspects of the SSR switching routers are tightly coupled.

The SSR can be used purely as an L2 switch. Frames arriving at any port are bridged and not routed. In this case, setting up VLANs and associating ports with VLANs is all that is required. You can set up the SSR switching router to use port-based VLANs, protocol-based VLANs, or a mixture of the two types.

The SSR can also be used purely as a router, i.e., each physical port of the SSR is a separate routing interface. Packets received at any interface are routed and not bridged. In this case, no VLAN configuration is required. Note that VLANs are still created implicitly by

the SSR as a result of creating L3 interfaces for IP and/or IPX. However, these implicit VLANs do not need to be created or configured manually. The implicit VLANs created by the SSR are subnet-based VLANs.

Most commonly, an SSR is used as a combined switch and router. For example, it may be connected to two subnets S1 and S2. Ports 1-8 belong to S1 and ports 9-16 belong to S2. The required behavior of the SSR is that intra-subnet frames be bridged and inter-subnet packets be routed. In other words, traffic between two workstations that belong to the same subnet should be bridged, and traffic between two workstations that belong to different subnets should be routed.

The SSR switching routers use VLANs to achieve this behavior. This means that a L3 subnet (i.e., an IP or IPX subnet) is mapped to a VLAN. A given subnet maps to exactly one and only one VLAN. With this definition, the terms *VLAN* and *subnet* are almost interchangeable.

To configure an SSR as a combined switch and router, the administrator must create VLANs whenever multiple ports of the SSR are to belong to a particular VLAN/subnet. Then the VLAN must be *bound to* an L3 (IP/IPX) interface so that the SSR knows which VLAN maps to which IP/IPX subnet.

### Ports, VLANs, and L3 Interfaces

The term *port* refers to a physical connector on the SSR, such as an ethernet port. Each port must belong to at least one VLAN. When the SSR is unconfigured, each port belongs to a VLAN called the “default VLAN”. By creating VLANs and adding ports to the created VLANs, the ports are moved from the default VLAN to the newly created VLANs.

Unlike traditional routers, the SSR has the concept of logical interfaces rather than physical interfaces. An L3 interface is a logical entity created by the administrator. It can contain more than one physical port. When an L3 interface contains exactly one physical port, it is equivalent to an interface on a traditional router. When an L3 interface contains several ports, it is equivalent to an interface of a traditional router which is connected to a layer-2 device such as a switch or bridge.

### Access Ports and Trunk Ports (802.1Q support)

The ports of an SSR can be classified into two types, based on VLAN functionality: **access ports** and **trunk ports**. By default, a port is an access port. An access port can belong to at most one VLAN of the following types: IP, IPX or bridged protocols. The SSR can automatically determine whether a received frame is an IP frame, an IPX frame or neither. Based on this, it selects a VLAN for the frame. Frames transmitted out of an access port are *untagged*, meaning that they contain no special information about the VLAN to which they belong. Untagged frames are classified as belonging to a particular VLAN based on the protocol of the frame and the VLAN configured on the receiving port for that protocol.

For example, if port 1 belongs to VLAN *IPX\_VLAN* for IPX, VLAN *IP\_VLAN* for IP and VLAN *OTHER\_VLAN* for any other protocol, then an IP frame received by port 1 is classified as belonging to VLAN *IP\_VLAN*.

Trunk ports (802.1Q) are usually used to connect one VLAN-aware switch to another. They carry traffic belonging to several VLANs. For example, suppose that SSR A and B are both configured with VLANs V1 and V2.

Then a frame arriving at a port on SSR A must be sent to SSR B, if the frame belongs to VLAN V1 or to VLAN V2. Thus the ports on SSR A and B which connect the two SSRs together must belong to both VLAN V1 and VLAN V2. Also, when these ports receive a frame, they must be able to determine whether the frame belongs to V1 or to V2. This is accomplished by “tagging” the frames, i.e., by prepending information to the frame in order to identify the VLAN to which the frame belongs. In the SSR switching routers, trunk ports always transmit and receive tagged frames only. The format of the tag is specified by the IEEE 802.1Q standard. The only exception to this is Spanning Tree Protocol frames, which are transmitted as untagged frames.

### Explicit and Implicit VLANs

As mentioned earlier, VLANs can either be created explicitly by the administrator (explicit VLANs) or are created implicitly by the SSR when L3 interfaces are created (implicit VLANs).

## Configuring SSR Bridging Functions

### Configure Address-based or Flow-based Bridging

The SSR ports perform address-based bridging by default but can be configured to perform flow-based bridging instead of address-based bridging, on a per-port basis. A port cannot be configured to perform both types of bridging at the same time.

The SSR performance is equivalent when performing flow-based bridging or address-based bridging. However, address-based bridging is more efficient because it requires fewer table entries while flow-based bridging provides tighter management and control over bridged traffic.

For example, the following illustration shows an SSR with traffic being sent from port A to port B, port B to port A, port B to port C, and port A to port C.

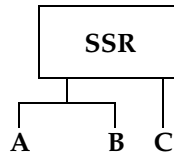

The corresponding bridge tables for address-based and flow-based bridging are shown below. As shown, the bridge table contains more information on the traffic patterns when flow-based bridging enabled compared to address-based bridging.

Address-Based Bridge Table	Flow-Based Bridge Table
A (source)	A → B
B (source)	B → A
C (destination)	B → C
	A → C

With the SSR configured in flow-based bridging mode, the network manager has “per flow” control of layer-2 traffic. The network manager can then apply Quality of Service (QoS) policies or security filters based layer-2 traffic flows.

To enable flow-based bridging on a port, enter the following command in Configure Mode.

Configure a port for flow-based bridging.	<b>port flow-bridging</b> <port-list> all-ports
---	---

To change a port from flow-based bridging to address-based bridging, enter the following command in Configure mode:

Change a port from flow-based bridging to address-based bridging.	<b>negate</b> <line-number of active config containing command>: <b>port flow-bridging</b> <port-list> all-ports
---	---

## Configuring Spanning Tree

The SSR supports only one spanning tree process per SSR. By default, spanning tree is disabled on the SSR. To enable spanning tree on the SSR, you perform the following task on the ports where you want spanning tree enabled.

**Note:** If you are running spanning tree on one or more VLANs, you must enable spanning tree on all ports belonging to each VLAN.

Enable spanning tree on one or more ports.	<code>stp enable port &lt;port-list&gt;</code>
--	--

## Adjust Spanning-Tree Parameters

You may need to adjust certain spanning-tree parameters if the default values are not suitable for your bridge configuration. Parameters affecting the entire spanning tree are configured with variations of the bridge global configuration command. Interface-specific parameters are configured with variations of the bridge-group interface configuration command.

You can adjust spanning-tree parameters by performing any of the tasks in the following sections:

- Set the Bridge Priority
- Set an Interface Priority

**Note:** Only network administrators with a good understanding of how bridges and the Spanning-Tree Protocol work should make adjustments to spanning-tree parameters. Poorly chosen adjustments to these parameters can have a negative impact on performance. A good source on bridging is the IEEE 802.1d specification.

### Set the Bridge Priority

You can globally configure the priority of an individual bridge when two bridges tie for position as the root bridge, or you can configure the likelihood that a bridge will be selected as the root bridge. The lower the bridge's priority, the more likely the bridge will be selected as the root bridge. This priority is determined by default; however, you can change it.

To set the bridge priority, enter the following command in Configure mode:

Set the bridge priority.	<code>stp set bridging priority &lt;num&gt;</code>
--------------------------	--

### Set a Port Priority

You can set a priority for an interface. When two bridges tie for position as the root bridge, you configure an interface priority to break the tie. The bridge with the lowest interface value is elected.



To set an interface priority, enter the following command in Configure mode:

Establish a priority for a specified interface.	<b>stp set port</b> <i>&lt;port-list&gt;</i> <b>priority</b> <i>&lt;num&gt;</i>
---	---

### Assign Port Costs

Each interface has a port cost associated with it. By convention, the port cost is 1000/data rate of the attached LAN, in Mbps. You can set different port costs.

To assign port costs, enter the following command in Configure mode:

Set a different port cost other than the defaults.	<b>stp set port</b> <i>&lt;port-list&gt;</i> <b>port-cost</b> <i>&lt;num&gt;</i>
--	--

### Adjust Bridge Protocol Data Unit (BPDU) Intervals

You can adjust BPDU intervals as described in the following sections:

- Adjust the Interval between Hello BPDUs
- Define the Forward Delay Interval
- Define the Maximum Idle Interval

#### Adjust the Interval between Hello Times

You can specify the interval between hello time.

To adjust this interval, enter the following command in Configure mode:

Specify the interval between hello time	<b>stp set bridging hello-time</b> <i>&lt;num&gt;</i>
---	---

#### Define the Forward Delay Interval

The forward delay interval is the amount of time spent listening for topology change information after an interface has been activated for bridging and before forwarding actually begins.

To change the default interval setting, enter the following command in Configure mode:

Set the default of the forward delay interval.	<b>stp set bridging forward-delay</b> <i>&lt;num&gt;</i>
--	--

### Define the Maximum Age

If a bridge does not hear BPDUs from the root bridge within a specified interval, it assumes that the network has changed and recomputes the spanning-tree topology.

To change the default interval setting, enter the following command in Configure mode:

Change the amount of time a bridge will wait to hear BPDUs from the root bridge.	<b>stp set bridging max-age</b> <i>&lt;num&gt;</i>
--	--

## Configuring a Port or Protocol based VLAN

To create a port or protocol based VLAN, perform the following steps in the Configure mode.

1. Create a port or protocol based VLAN.
2. Add physical ports to a VLAN.

### Create a Port or Protocol Based VLAN

To create a VLAN, perform the following command in the Configure mode.

Create a VLAN.	<b>vlan create</b> <i>&lt;vlan-name&gt;</i> <i>&lt;type&gt;</i> <b>id</b> <i>&lt;num&gt;</i>
----------------	--

### Adding Ports to a VLAN

To add ports to a VLAN, perform the following command in the Configure mode.

Add ports to a VLAN.	<b>vlan add ports</b> <i>&lt;port-list&gt;</i> <b>to</b> <i>&lt;vlan-name&gt;</i>
----------------------	---

## Configuring VLAN Trunk Ports

The SSR supports standards-based VLAN trunking between multiple SSRs as defined by IEEE 802.1Q. 802.1Q adds a header to a standard Ethernet frame which includes a unique VLAN id per trunk between two SSRs. These VLAN ids extend the VLAN broadcast domain to more than one SSR.

To configure a VLAN trunk, perform the following command in the Configure mode.

Configure 802.1Q VLAN trunks.	<b>vlan make</b> <i>&lt;port-type&gt;</i> <i>&lt;port-list&gt;</i>
-------------------------------	--

## Configure Bridging for Non-IP/IPX Protocols

By default, all non-routable protocols (AppleTalk and DECnet) are bridged within the SSR. All physical ports containing non-routable protocols should be assigned to the same VLAN, thus allowing bridging between ports. Routing can still be performed on the defined VLAN by assigning an IP or IPX interface.

## Configure Layer-2 Filters

Layer-2 security filters on the SSR allow you to configure ports to filter specific MAC addresses. When defining a Layer-2 security filter, you specify to which ports you want the filter to apply. Refer to the *“Security Configuration Chapter”* for details on configuring Layer-2 filters. You can specify the following security filters:

- Address filters

These filters block traffic based on the frame's source MAC address, destination MAC address, or both source and destination MAC addresses in flow bridging mode. Address filters are always configured and applied to the input port.

- Port-to-address lock filters

These filters prohibit a user connected to a locked port or set of ports from using another port.

- Static entry filters

These filters allow or force traffic to go to a set of destination ports based on a frame's source MAC address, destination MAC address, or both source and destination MAC addresses in flow bridging mode. Static entries are always configured and applied at the input port.

- Secure port filters

A secure filter shuts down access to the SSR based on MAC addresses. All packets received by a port are dropped. When combined with static entries, however, these filters can be used to drop all received traffic but allow some frames to go through.

## Monitor Bridging

The SSR provides display of bridging statistics and configurations contained in the SSR.

To display bridging information, enter the following commands in Enable mode.

Show IP routing table.	<code>ip show routes</code>
Show all MAC addresses currently in the l2 tables.	<code>l2-tables show all-macs</code>

Show l2 table information on a specific port.	<b>12-tables show port-macs</b>
Show information the master MAC table.	<b>12-tables show mac-table-stats</b>
Show information on a specific MAC address.	<b>12-tables show mac</b>
Show information on MACs registered.	<b>12-table show bridge-management</b>
Show all VLANs.	<b>vlan list</b>

## Configuration Examples

### Creating an IP or IPX VLAN

VLANs are used to associate physical ports on the SSR with connected hosts that may be physically separated but need to participate in the same broadcast domain. To associate ports to a VLAN, you must first create an IP or IPX VLAN and then assign ports to the VLAN.

For example, servers connected to port gi.1.(1-2) on the SSR need to communicate with clients connected to et.4.(1-8). You can associate all the ports containing the clients and servers to an IP VLAN called 'BLUE'.

First, create an IP VLAN named 'BLUE'

```
ssr(config)# vlan create BLUE ip
```

Next, assign ports to the 'BLUE' VLAN.

```
ssr(config)# vlan add ports et.1.(1-8) gi.1.(1-2) to BLUE
```

# Chapter 3

## IP Routing Configuration Guide

This chapter describes how to configure IP interfaces and general non-protocol-specific routing parameters.

### IP Routing Overview

Internet Protocol (IP) is a packet-based protocol used to exchange data over computer networks. IP handles addressing, routing, fragmentation, reassembly, and protocol demultiplexing. In addition, IP specifies how hosts and routers should process packets, handle errors and discard packets. IP forms the foundation upon which transport layer protocols, such as TCP or UDP, interoperate over a routed network.

The Transmission Control Protocol (TCP) is built upon the IP layer. TCP is a connection-oriented protocol that specifies the data format, buffering and acknowledgments used in the transfer of data. TCP is a full-duplex connection which also specifies the procedures that the computers use to ensure that the data arrives correctly.

The User Datagram Protocol (UDP) provides the primary mechanism that applications use to send datagrams to other application programs. UDP is a connectionless protocol that does not guarantee delivery of datagrams between applications. Applications which use UDP are responsible for ensuring successful data transfer by employing error handling, retransmission and sequencing techniques.

TCP and UDP also specify “ports,” which identify the application which is using TCP/UDP. For example, a web server would typically use TCP/UDP port 80, which specifies HTTP-type traffic.

The SSR supports standards based TCP, UDP, and IP.

## IP Routing Protocols

The SSR supports standards based unicast and multicast routing. Unicast routing protocol support include Interior Gateway Protocols and Exterior Gateway Protocols. Multicast routing protocols are used to determine how multicast data is transferred in a routed environment.

### Unicast Routing Protocols

Interior Gateway Protocols are used for routing networks that are within an “autonomous system,” a network of relatively limited size. All IP interior gateway protocols must be specified with a list of associated networks before routing activities can begin. A routing process listens to updates from other routers on these networks and broadcasts its own routing information on those same networks. The SSR supports the following Interior Gateway Protocols:

- Routing Information Protocol (RIP) Version 1, 2 (RFC 1058, 1723)
- Open Shortest Path First (OSPF) Version 2 (RFC 1583)

Exterior Gateway Protocols are used to transfer information between different “autonomous systems”. The SSR supports the following Exterior Gateway Protocol:

- Border Gateway Protocol (BGP) Version 3, 4 (RFC 1267, 1771)

### Multicast Routing Protocols

IP multicasting allows a host to send traffic to a subset of all hosts. These hosts subscribe to group membership, thus notifying the SSR of participation in a multicast transmission.

Multicast routing protocols are used to determine which routers have directly attached hosts, as specified by IGMP, that have membership to a multicast session. Once host memberships are determined, routers use multicast routing protocols, such as DVMRP, to forward multicast traffic between routers.

The SSR supports the following multicast routing protocols:

- Distance Vector Multicast Routing Protocol (DVMRP) RFC 1075
- Internet Group Management Protocol (IGMP) as described in RFC 2236

The SSR also supports the latest DVMRP Version 3.0 draft specification, which includes mtrace, Generation ID and Pruning/Grafting.

## Configuring IP Interfaces and Parameters

This section provides an overview of configuring various IP parameters and setting up IP interfaces.

### Configure IP Addresses to Ports

You can configure one IP interface directly to physical ports. Each port can be assigned multiple IP addresses representing multiple subnets connected to the physical port.

To configure an IP interface to a port, enter one of the following commands in Configure mode.

Configure an IP interface to a physical port.	<b>interface create ip</b> <InterfaceName> <b>address-mask</b> <ipAddr-mask> <b>port</b> <port>
Configure a secondary address to an existing IP interface.	<b>interface add ip</b> <InterfaceName> <b>address-netmask</b> <ipAddr-mask> <b>[broadcast</b> <ipaddr>]

### Configure IP Interfaces for a VLAN

You can configure one IP interface per VLAN. Once an IP interface has been assigned to a VLAN, you can add a secondary IP addresses to the VLAN.

To configure a VLAN with an IP interface, enter the following command in Configure mode:

Create an IP interface for a VLAN.	<b>interface create ip</b> <InterfaceName> <b>address-mask</b> <ipAddr-mask> <b>vlan</b> <name>
Configure a secondary address to an existing VLAN.	<b>interface add ip</b> <InterfaceName> <b>address-netmask</b> <ipAddr-mask> <b>vlan</b> <name>

### Specify Ethernet Encapsulation Method

The SmartSwitch Router supports two encapsulation types for IP. You can configure encapsulation type on a per-interface basis.

- Ethernet II: The standard ARPA Ethernet Version 2.0 encapsulation, which uses a 16-bit protocol type code (the default encapsulation method)

- 802.3 SNAP: SNAP IEEE 802.3 encapsulation, in which the type code becomes the frame length for the IEEE 802.2 LLC encapsulation (destination and source Service Access Points, and a control byte)

To configure IP encapsulation, enter one of the following commands in Configure mode.

Configure Ethernet II encapsulation.	<b>interface create ip &lt;InterfaceName&gt; output-mac-encapsulation ethernet_II</b>
Configure 802.3 SNAP encapsulation.	<b>interface create ip &lt;InterfaceName&gt; output-mac-encapsulation ethernet_snap</b>

## Configure Address Resolution Protocol

The SSR allows you to configure Address Resolution Protocol (ARP) table entries and parameters. ARP is used to associate IP addresses with media or MAC addresses. Taking an IP address as input, ARP determines the associated MAC address. Once a media or MAC address is determined, the IP address/media address association is stored in an ARP cache for rapid retrieval. Then the IP datagram is encapsulated in a link-layer frame and sent over the network.

### Configure ARP Cache Entries

You can add and delete entries in the ARP cache. To add or delete static ARP entries, enter one of the the following commands in Configure mode:

Add a static ARP entry.	<b>arp add &lt;host&gt; mac-addr &lt;MAC-addr&gt; exit-port &lt;port&gt;</b>
Clear a static ARP entry.	<b>arp clear &lt;host&gt;</b>

### Configure Proxy ARP

The SSR can be configured for proxy ARP. The SSR uses proxy ARP (as defined in RFC 1027) to help hosts with no knowledge of routing determine the MAC address of hosts on other networks or subnets. Through Proxy ARP, the SSR will respond to ARP requests from a host with a ARP reply packet containing the SSR MAC address. Proxy ARP is enabled by default on the SSR.

To disable proxy ARP, enter the following command in Configure mode:

Disable Proxy ARP on an interface.	<b>ip disable-proxy-arp interface &lt;InterfaceName&gt; all</b>
------------------------------------	---



## Configure DNS Parameters

The SSR can be configured to specify DNS servers which supply name services for DNS requests. You can specify up to three DNS servers.

To configure DNS servers, enter the following command in Configure mode:

Configure a DNS server.	<b>system set dns server</b> <IPaddr> [ <IPaddr>[ <IPaddr>]]
-------------------------	---

You can also specify a domain name for the SSR. The domain name is used by the SSR to respond to DNS requests.

To configure a domain name, enter the following command in Configure mode:

Configure a domain name.	<b>system set dns domain</b> <name>
--------------------------	-------------------------------------

## Configure IP Services (ICMP)

The SSR provides ICMP message capabilities including ping and traceroute. Ping allows you to determine the reachability of a certain IP host. Traceroute allows you to trace the IP gateways to an IP host.

To access ping or traceroute on the SSR, enter the following commands in Enable mode:

Specify ping.	<b>ping</b> <hostname-or-IPaddr> <b>packets</b> <num> <b>size</b> <num> <b>wait</b> <num> [ <b>flood</b> ] [ <b>dontroute</b> ]
Specify traceroute.	<b>traceroute</b> <host> [ <b>max-ttl</b> <num>] [ <b>probes</b> <num>] [ <b>size</b> <num>] [ <b>source</b> <secs>] [ <b>tos</b> <num>] [ <b>wait-time</b> <secs>] [ <b>verbose</b> ] [ <b>noroute</b> ]

## Configure IP Helper

You can configure the SSR to forward UDP broadcast packets received on a given interface to a specified IP address. You can specify a UDP port number for which UDP broadcast packets with that destination port number will be forwarded. By default, if no UDP port number is specified, the SSR will forward UDP broadcast packets for the following six services:

- BOOTP/DHCP (port 67 and 68)
- DNS (port 37)
- NetBIOS Name Server (port 137)

- NetBIOS Datagram Server (port 138)
- TACACS Server (port 49)
- Time Service (port 37)

To configure a destination to which UDP packets will be forwarded, enter the following command in Configure mode:

Specify local subnet interface, destination "helper" IP address, and UDP port number to forward	<b>ip helper-address interface</b> <interface-name> <helper-address> <udp-port#>
---	---

## Configure Direct Broadcast

You can configure the SSR to forward all directed broadcast traffic from the local subnet to a specified IP address or all associated IP addresses. This is a more efficient method than defining only one local interface and remote IP address destination at a time with the **ip-helper** command when you are forwarding traffic from more than one interface in the local subnet to a remote destination IP address.

To forward all directed broadcast traffic to a specified IP address, enter the following command in Configure mode:

Forward directed broadcast traffic	<b>ip enable directed-broadcast interface</b> <interface name>   <b>all</b>
------------------------------------	--

## Monitor IP Parameters

The SSR provides display of IP statistics and configurations contained in the routing table. Information displayed provides routing and performance information.

To display IP information, enter the following command in Enable mode:

Show ARP table entries.	<b>arp show all</b>
Show IP interface configuration	<b>interface show ip</b>
Show all TCP/UDP connections and services.	<b>ip show connections [no-lookup]</b>
Show configuration of IP interfaces.	<b>ip show interfaces [&lt;interface-name&gt;]</b>
Show IP routing table information.	<b>ip show routes</b>

Show ARP entries in routing table.	<code>ip show routes show-arps</code>
Show DNS parameters.	<code>system show dns</code>

## Configuration Examples

### Assigning IP/IPX Interfaces

To enable routing on the SSR, you must assign an IP or IPX interface to a VLAN. To assign an IP or IPX interface named 'RED' to the 'BLUE' VLAN, enter the following command:

```
ssr(config)# interface create ip RED address-netmask  
10.50.0.1/255.255.0.0 vlan BLUE
```

You can also assign an IP or IPX interface directly to a physical port. For example, to assign an IP interface 'RED' to physical port et.3.4, perform the following:

```
ssr(config)# interface create ip RED address-netmask  
10.50.0.0/255.255.0.0 port et.3.4
```



# Chapter 4

## RIP Configuration Guide

### RIP Overview

This chapter describes how to configure Routing Information Protocol (RIP) in the SmartSwitch Router. RIP is a distance-vector routing protocol for use in small networks. RIP is described in RFC 1723. A router running RIP broadcasts updates at set intervals. Each update contains paired values where each pair consists of an IP network address and an integer distance to that network. RIP uses a hop count metric to measure the distance to a destination.

The SmartSwitch Router provides support for RIP Version 1 and 2. The SSR implements plain text and MD5 authentication methods for RIP Version 2.

The protocol independent features that apply to RIP are described in [Chapter 3: “IP Routing Configuration Guide” on page 45](#).

### Configure RIP

By default, RIP is disabled on the SSR and on each of the attached interfaces. To configure RIP on the SSR, follow these steps:

1. Start the RIP process by entering the **rip start** command.
2. Use the **rip add interface** command to inform RIP about the attached interfaces.

## Enabling and Disabling RIP

To enable or disable RIP, enter one of the following commands in Configure mode.

Enable RIP.	<b>rip start</b>
Disable RIP.	<b>rip stop</b>

## Configuring RIP Interfaces

To configure RIP in the SSR, you must first add interfaces to inform RIP about attached interfaces.

To add RIP interfaces, enter the following commands in Configure mode.

Add interfaces to the RIP process.	<b>rip add interface</b> <interfacename-or-IPaddr>
Add gateways from which the SSR will accept RIP updates.	<b>rip add trusted-gateway</b> <interfacename-or-IPaddr>
Define the list of routers to which RIP sends packets directly, not through multicast or broadcast.	<b>rip add source-gateway</b> <interfacename-or-IPaddr>

## Configure RIP Parameters

No further configuration is required and the system default parameters will be used by RIP to exchange routing information. These default parameters may be modified to suit your needs by using the *rip set interface* command.

RIP Parameter	Default Value
Version number	RIP v1
Check-zero for RIP reserved parameters	Enabled
Whether RIP packets should be broadcast	Choose
Preference for RIP routes	100
Metric for incoming routes	1
Metric for outgoing routes	0

RIP Parameter	Default Value
Authentication	None
Update interval	30 seconds

To change RIP parameters, enter the following commands in Configure mode.

Set RIP Version on an interface to RIP V1.	<b>rip set interface</b> <interfacename-or-IPaddr>   <b>all version 1</b>
Set RIP Version on an interface to RIP V2.	<b>rip set interface</b> <interfacename-or-IPaddr>   <b>all version 2</b>
Specify that RIP V2 packets should be multicast on this interface.	<b>rip set interface</b> <interfacename-or-IPaddr>   <b>all type multicast</b>
Specify that RIP V2 packets that are RIP V1-compatible should be broadcast on this interface.	<b>rip set interface</b> <interfacename-or-IPaddr>   <b>all type broadcast</b>
Change the metric on incoming RIP routes.	<b>rip set interface</b> <interfacename-or-IPaddr>   <b>all metric-in</b> <num>
Change the metric on outgoing RIP routes.	<b>rip set interface</b> <interfacename-or-IPaddr>   <b>all metric-out</b> <num>
Set the authentication method to simple text up to 8 characters.	<b>rip set interface</b> <interfacename-or-IPaddr>   <b>all authentication-method simple</b>
Set the authentication method to MD5.	<b>rip set interface</b> <interfacename-or-IPaddr>   <b>all authentication-method md5</b>
Specify the metric to be used when advertising routes that were learned from other protocols.	<b>rip set default-metric</b> <num>

## Configure RIP Route Preference

You can set the preference of routes learned from RIP.

To configure RIP route preference, enter the following command in Configure mode.

Set the preference of routes learned from RIP.	<b>rip set preference</b> <num>
--	---------------------------------

## Configure RIP Route Default-Metric

You can define the metric used when advertising routes via RIP that were learned from other protocols. The default value for this parameter is 16 (unreachable). To export routes from other protocols into RIP, you must explicitly specify a value for the default-metric parameter. The metric specified by the default-metric parameter may be overridden by a metric specified in the export command.

To configure default-metric, enter the following command in Configure mode.

Define the metric used when advertising routes via RIP that were learned from other protocols.	<b>rip set default-metric &lt;num&gt;</b>
--	---

For <num>, you must specify a number between 1 and 16.

## Monitoring RIP

The *rip trace* command can be used to trace all rip request and response packets.

To monitor RIP information, enter the following commands in Enable mode.

Show all RIP information.	<b>rip show all</b>
Show RIP export policies.	<b>rip show export-policy</b>
Show RIP global information.	<b>rip show globals</b>
Show RIP import policies.	<b>rip show import-policy</b>
Show RIP information on the specified interface.	<b>rip show interface &lt;Name or IP-addr&gt;</b>
Show RIP interface policy information.	<b>rip show interface-policy</b>
Show detailed information of all RIP packets	<b>rip trace packets detail</b>
Show detailed information of all packets received by the router.	<b>rip trace packets receive</b>
Show detailed information of all packets sent by the router.	<b>rip trace packets send</b>
Show detailed information of all request received by the router.	<b>rip trace request receive</b>
Show detailed information of all response received by the router.	<b>rip trace response receive</b>



Show detailed information of response packets sent by the router.	<code>rip trace response send</code>
Show detailed information of request packets sent by the router.	<code>rip trace send request</code>
Show RIP timer information.	<code>rip show timers</code>

## Configuration Example

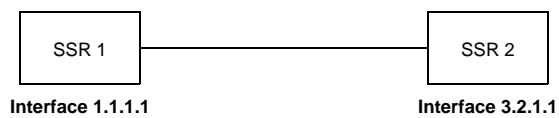

```

! Example configuration
!
! Create interface ssr1-if1 with ip address 1.1.1.1/16 on port et.1.1 on SSR-1
interface create ip ssr1-if1 address-netmask 1.1.1.1/16 port et.1.1
!
! Configure rip on SSR-1
rip add interface ssr1-if1
rip set interface ssr1-if1 version 2
rip start
!
!
! Set authentication method to md5
rip set interface ssr1-if1 authentication-method md5
!
! Change default metric-in
rip set interface ssr1-if1 metric-in 2
!
! Change default metric-out
rip set interface ssr1-if1 metric-out 3
  
```



# Chapter 5

# OSPF Configuration Guide

## OSPF Overview

Open Shortest Path First (OSPF) is a link-state routing protocol that supports IP subnetting and authentication. The SSR supports OSPF Version 2.0 as defined in RFC 1583. Each link-state message contains all the links connected to the router with a specified cost associated with the link.

The SSR supports the following OSPF functions:

- Stub Areas: Definition of stub areas is supported
- Authentication: Simple password and MD5 authentication methods are supported within an area
- Virtual Links: Virtual links are supported
- Route Redistribution: Routes learned via RIP, BGP, or any other sources can be redistributed into OSPF. OSPF routes can be redistributed into RIP or BGP
- Interface Parameters: Parameters that can be configured include interface output cost, retransmission interval, interface transmit delay, router priority, router dead and hello intervals, and authentication key

## OSPF Multipath

The SSR also supports OSPF and static Multi-path. If multiple equal-cost OSPF or static routes have been defined for any destination, then the SSR “discovers” and uses all of them. The SSR will automatically learn up to four equal-cost OSPF or static routes and retain them in its forwarding information base (FIB). The forwarding module then installs flows for these destinations in a round-robin fashion.

## Configure OSPF

To configure OSPF on the SSR, you must enable OSPF, create OSPF areas, assign interfaces to OSPF areas, and, if necessary, specify any of the OSPF interface parameters.

To configure OSPF, you may need to perform some or all of the following tasks:

- Enable OSPF.
- Create OSPF areas.
- Create an IP interface or assign an IP interface to a VLAN.
- Add IP interfaces to OSPF areas.
- Configure OSPF interface parameters, if necessary.

**Note:** By default, the priority of an OSPF router for an interface is set to zero, which makes the router ineligible from becoming a designated router on the network to which the interface belongs. To make the router eligible to become a designated router, you must set the priority to a non-zero value.

The default cost of an OSPF interface is 1. The cost of the interface should be inversely proportional to the bandwidth of the interface; if the SSR has interfaces with differing bandwidths, the OSPF costs should be set accordingly.

- Add IP networks to OSPF areas.
- Create virtual links, if necessary.

## Enable OSPF

OSPF is disabled by default on the SSR.

To enable or disable OSPF, enter one of the following commands in Configure mode.

Enable OSPF.	<code>ospf start</code>
Disable OSPF.	<code>ospf stop</code>

## Configure OSPF Interface Parameters

You can configure the OSPF interface parameters shown in the table below.

**Table 3. OSPF Interface Parameters**

OSPF Parameter	Default Value
Interface OSPF State (Enable/Disable)	Enable (except for virtual links)
Cost	1
No multicast	Default is using multicast mechanism.
Retransmit interval	5 seconds
Transit delay	1 second
Priority	0
Hello interval	10 seconds (broadcast), 30 (non broadcast)
Router dead interval	4 times the hello interval
Poll Interval	120 seconds
Key chain	N/A
Authentication Method	None

To configure OSPF interface parameters, enter one of the following commands in Configure mode:

Enable OSPF state on interface.	<b>ospf set interface &lt;name-or-IPaddr&gt; all state disable enable</b>
Specify the cost of sending a packet on an OSPF interface.	<b>ospf set interface &lt;name-or-IPaddr&gt; all cost &lt;num&gt;</b>
Specify the priority for determining the designated router on an OSPF interface.	<b>ospf set interface &lt;name-or-IPaddr&gt; all priority &lt;num&gt;</b>
Specify the interval between OSPF hello packets on an OSPF interface.	<b>ospf set interface &lt;name-or-IPaddr&gt; all hello-interval &lt;num&gt;</b>
Configure the retransmission interval between link state advertisements for adjacencies belonging to an OSPF interface.	<b>ospf set interface &lt;name-or-IPaddr&gt; all retransmit-interval &lt;num&gt;</b>

Specify the number of seconds required to transmit a link state update on an OSPF interface.	<b>ospf set interface</b> <name-or-IPaddr> all <b>transit-delay</b> <num>
Specify the time a neighbor router will listen for OSPF hello packets before declaring the router down.	<b>ospf set interface</b> <name-or-IPaddr> all <b>router-dead-interval</b> <num>
Disable IP multicast for sending OSPF packets to neighbors on an OSPF interface.	<b>ospf set interface</b> <name-or-IPaddr> all <b>no-multicast</b>
Specify the poll interval on an OSPF interface.	<b>ospf set interface</b> <name-or-IPaddr> all <b>poll-interval</b> <num>
Specify the identifier of the key chain containing the authentication keys.	<b>ospf set interface</b> <name-or-IPaddr> all <b>key-chain</b> <num-or-string>
Specify the authentication method to be used on this interface.	<b>ospf set interface</b> <name-or-IPaddr> all <b>authentication-method</b> none simple md5

## Configure an OSPF Area

OSPF areas are a collection of subnets that are grouped in a logical fashion. These areas communicate with other areas via the backbone area. Once OSPF areas are created, you can add interfaces, stub hosts, and summary ranges to the area.

In order to reduce the amount of routing information propagated between areas, you can configure summary-ranges on Area Border Routers (ABRs). On the SSR, summary-ranges are created using the **ospf add network** command – the networks specified using this command describe the scope of an area. Intra-area Link State Advertisements (LSAs) that fall within the specified ranges are not advertised into other areas as inter-area routes. Instead, the specified ranges are advertised as summary network LSAs.

To create areas and assign interfaces, enter the following commands in the Configure mode.

Create an OSPF area.	<b>ospf create area</b> <area-num> backbone
Add an interface to an OSPF area.	<b>ospf add interface</b> <name-or-IPaddr> [to-area <area-addr>  backbone] [type broadcast non-broadcast]

Add a stub host to an OSPF area.	<b>ospf add stub-host</b> [to-area <area-addr> backbone] [cost <num>]
Add a network to an OSPF area for summarization.	<b>ospf add network</b> <IPaddr/mask> [to-area <area-addr> backbone] [restrict] [host-net]

## Configure OSPF Area Parameters

The SSR allows configuration of various OSPF area parameters, including stub areas, stub cost and authentication method. Stub areas are areas into which information on external routes is not sent. Instead, there is a default external route generated by the ABR, into the stub area for destinations outside the autonomous system. Stub cost specifies the cost to be used to inject a default route into a stub area. An authentication method for OSPF packets can be specified on a per-area basis.

To configure OSPF area parameters, enter the following commands in the Configure mode.

Specify an OSPF stub area.	<b>ospf set area</b> <area-num> <b>stub</b>
Specify the cost to be used to inject a default route into an area.	<b>ospf set area</b> <area-num> <b>stub-cost</b> <num>
Specify the authentication method to be used by neighboring OSPF routers.	<b>ospf set area</b> <area-num> [ <b>stub</b> ] [ <b>authentication-method</b> <b>none simple md5</b> ]

## Create Virtual Links

In OSPF, virtual links can be established:

- To connect an area via a transit area to the backbone
- To create a redundant backbone connection via another area

Each Area Border Router must be configured with the same virtual link. Note that virtual links cannot be configured through a stub area.

To configure virtual links, enter the following commands in the Configure mode.

Create a virtual link.	<b>ospf add virtual-link</b> <i>&lt;number-or-string&gt;</i> [ <b>neighbor</b> <i>&lt;IPAddr&gt;</i> ] [ <b>transit-area</b> <i>&lt;area-num&gt;</i> ]
Set virtual link parameters.	<b>ospf set virtual-link</b> <i>&lt;number-or-string&gt;</i> [ <b>state</b> <i>disable enable</i> ] [ <b>cost</b> <i>&lt;num&gt;</i> ] [ <b>retransmit-interval</b> <i>&lt;num&gt;</i> ] [ <b>transit-delay</b> <i>&lt;num&gt;</i> ] [ <b>priority</b> <i>&lt;num&gt;</i> ] [ <b>hello-interval</b> <i>&lt;num&gt;</i> ] [ <b>router-dead-interval</b> <i>&lt;num&gt;</i> ] [ <b>poll-interval</b> <i>&lt;num&gt;</i> ]

## Configure Autonomous System External (ASE) Link Advertisements

These parameters specify the defaults used when importing OSPF AS External (ASE) routes into the routing table and exporting routes from the routing table into OSPF ASEs.

To specify AS external link advertisements parameters, enter the following commands in the Configure mode:

Specify the interval which AS external link advertisements will be generated and flooded to an OSPF AS.	<b>ospf set export-interval</b> <i>&lt;num&gt;</i>
Specify the number of AS external link advertisements which will be generated and flooded to an OSPF AS.	<b>ospf set export-limit</b> <i>&lt;num&gt;</i>
Specify AS external link advertisement default parameters.	<b>ospf set ase-defaults</b> [ <b>preference</b> <i>&lt;num&gt;</i> ] [ <b>cost</b> <i>&lt;num&gt;</i> ] [ <b>type</b> <i>&lt;num&gt;</i> ] [ <b>inherit-metric</b> ]

## Configure OSPF over Non-Broadcast Multiple Access

You can configure OSPF over NBMA circuits to limit the number of Link State Advertisements (LSAs). LSAs are limited to initial advertisements and any subsequent changes. Periodic LSAs over NBMA circuits are suppressed.

To configure OSPF over WAN circuits, enter the following command in Configure mode:

Configure OSPF over a WAN circuit.	<b>ospf add nbma-neighbor</b> <i>&lt;hostname-or-IPAddr&gt;</i> <b>to-interface</b> <i>&lt;name-or-IPAddr&gt;</i> [ <b>eligible</b> ]
------------------------------------	---



## Monitoring OSPF

The SSR provides display of OSPF statistics and configurations contained in the routing table. Information displayed provides routing and performance information.

To display OSPF information, enter the following commands in Enable mode.

Show IP routing table.	<b>ip show table routing</b>
Monitor OSPF error conditions.	<b>ospf monitor errors destination</b> <i>&lt;hostname-or-IPaddr&gt;</i>
Show information on all interfaces configured for OSPF.	<b>ospf monitor interfaces destination</b> <i>&lt;hostname-or-IPaddr&gt;</i>
Display link state advertisement information.	<b>ospf monitor lsa destination</b> <i>&lt;hostname-or-IPaddr&gt;</i>
Display the link state database.	<b>ospf monitor lsdb destination</b> <i>&lt;hostname-or-IPaddr&gt;</i>
Shows information about all OSPF routing neighbors.	<b>ospf monitor neighborsdestination</b> <i>&lt;hostname-or-IPaddr&gt;</i>
Show information on valid next hops.	<b>ospf monitor next-hop-list destination</b> <i>&lt;hostname-or-IPaddr&gt;</i>
Display OSPF routing table.	<b>ospf monitor routes destination</b> <i>&lt;hostname-or-IPaddr&gt;</i>
Monitor OSPF statistics for a specified destination.	<b>ospf monitor statistics destination</b> <i>&lt;hostname-or-IPaddr&gt;</i>
Shows information about all OSPF routing version	<b>ospf monitor version</b>
Shows OSPF Autonomous System External Link State Database.	<b>ospf sbow AS-External-LSDB</b>
Show all OSPF tables.	<b>ospf show all</b>
Show all OSPF areas.	<b>ospf show areas</b>
Show OSPF errors.	<b>ospf show errors</b>
Show information about OSPF export policies.	<b>ospf show export-policies</b>
Shows routes redistributed into OSPF.	<b>ospf show exported-routes</b>
Show all OSPF global parameters.	<b>ospf show globals</b>
Show information about OSPF import policies.	<b>ospf show import-policies</b>

Show OSPF interfaces.	<code>ospf show interfaces</code>
Shows information about all valid next hops mostly derived from the SPF calculation.	<code>ospf show next-hop-list</code>
Show OSPF statistics.	<code>ospf show statistics</code>
Shows information about OSPF Border Routes.	<code>ospf show summary-asb</code>
Show OSPF timers.	<code>ospf show timers</code>
Show OSPF virtual-links.	<code>ospf show virtual-links</code>

## OSPF Configuration Examples

For all examples in this section, refer to the configuration shown in [Figure 1 on page 70](#).

The following configuration commands for router R1:

- Determine the IP address for each interface
- Specify the static routes configured on the router
- Determine its OSPF configuration

```

!+++++
! Create the various IP interfaces.
!+++++
interface create ip to-r2 address-netmask 120.190.1.1/16 port et.1.2
interface create ip to-r3 address-netmask 130.1.1.1/16 port et.1.3
interface create ip to-r41 address-netmask 140.1.1.1/24 port et.1.4
interface create ip to-r42 address-netmask 140.1.2.1/24 port et.1.5
interface create ip to-r6 address-netmask 140.1.3.1/24 port et.1.6
!+++++
! Configure default routes to the other subnets reachable through R2.
!+++++
ip add route 202.1.0.0/16 gateway 120.1.1.2
ip add route 160.1.5.0/24 gateway 120.1.1.2
!+++++
! OSPF Box Level Configuration
!+++++
ospf start
ospf create area 140.1.0.0
ospf create area backbone
ospf set ase-defaults cost 4
!+++++
! OSPF Interface Configuration
!+++++
ospf add interface 140.1.1.1 to-area 140.1.0.0

```

```
ospf add interface 140.1.2.1 to-area 140.1.0.0
ospf add interface 140.1.3.1 to-area 140.1.0.0
ospf add interface 130.1.1.1 to-area backbone
```

### Exporting All Interface & Static Routes to OSPF

Router R1 has several static routes. We would export these static routes as type-2 OSPF routes. The interface routes would be redistributed as type-1 OSPF routes.

1. Create a OSPF export destination for type-1 routes since we would like to redistribute certain routes into OSPF as type 1 OSPF-ASE routes.

```
ip-router policy create ospf-export-destination ospfExpDstType1 type
1 metric 1
```

2. Create a OSPF export destination for type-2 routes since we would like to redistribute certain routes into OSPF as type 2 OSPF-ASE routes.

```
ip-router policy create ospf-export-destination ospfExpDstType2 type
2 metric 4
```

3. Create a Static export source since we would like to export static routes.

```
ip-router policy create static-export-source statExpSrc
```

4. Create a Direct export source since we would like to export interface/direct routes.

```
ip-router policy create direct-export-source directExpSrc
```

5. Create the Export-Policy for redistributing all interface routes and static routes into OSPF.

```
ip-router policy export destination ospfExpDstType1 source
directExpSrc network all
ip-router policy export destination ospfExpDstType2 source
statExpSrc network all
```

### Export All RIP, Interface & Static Routes to OSPF

**Note:** Also export interface, static, RIP, OSPF, and OSPF-ASE routes into RIP.

In the configuration shown in [Figure 1 on page 70](#), suppose if we decide to run RIP Version 2 on network 120.190.0.0/16, connecting routers R1 and R2.

We would like to redistribute these RIP routes as OSPF type-2 routes, and associate the tag 100 with them. Router R1 would also like to redistribute its static routes as type 2 OSPF routes. The interface routes would be redistributed as type 1 OSPF routes.

Router R1 would like to redistribute its OSPF, OSPF-ASE, RIP, Static and Interface/Direct routes into RIP.

1. Enable RIP on interface 120.190.1.1/16.

```
ip add interface 120.190.1.1
rip set interface 120.190.1.1 version 2 type multicast
```

2. Create a OSPF export destination for type-1 routes.

```
ip-router policy create ospf-export-destination ospfExpDstType1 type
1 metric 1
```

3. Create a OSPF export destination for type-2 routes.

```
ip-router policy create ospf-export-destination ospfExpDstType2 type
2 metric 4
```

4. Create a OSPF export destination for type-2 routes with a tag of 100.

```
ip-router policy create ospf-export-destination ospfExpDstType2t100
type 2 tag 100 metric 4
```

5. Create a RIP export source.

```
ip-router policy export destination ripExpDst source ripExpSrc
network all
```

6. Create a Static export source.

```
ip-router policy create static-export-source statExpSrc
```

7. Create a Direct export source.

```
ip-router policy create direct-export-source directExpSrc
```

8. Create the Export-Policy for redistributing all interface, RIP and static routes into OSPF.

```
ip-router policy export destination ospfExpDstType1 source
directExpSrc network all
ip-router policy export destination ospfExpDstType2 source
statExpSrc network all
ip-router policy export destination ospfExpDstType2t100 source
ripExpSrc network all
```

9. Create a RIP export destination.

```
ip-router policy create rip-export-destination ripExpDst
```

10. Create OSPF export source.

```
ip-router policy create ospf-export-source ospfExpSrc type OSPF
```

11. Create OSPF-ASE export source.

```
ip-router policy create ospf-export-source ospfAseExpSrc type OSPF-ASE
```

12. Create the Export-Policy for redistributing all interface, RIP, static, OSPF and OSPF-ASE routes into RIP.

```
ip-router policy export destination ripExpDst source statExpSrc
network all
ip-router policy export destination ripExpDst source ripExpSrc
network all
ip-router policy export destination ripExpDst source directExpSrc
network all
ip-router policy export destination ripExpDst source ospfExpSrc
network all
ip-router policy export destination ripExpDst source ospfAseExpSrc
network all
```

Figure 1. Exporting to OSPF

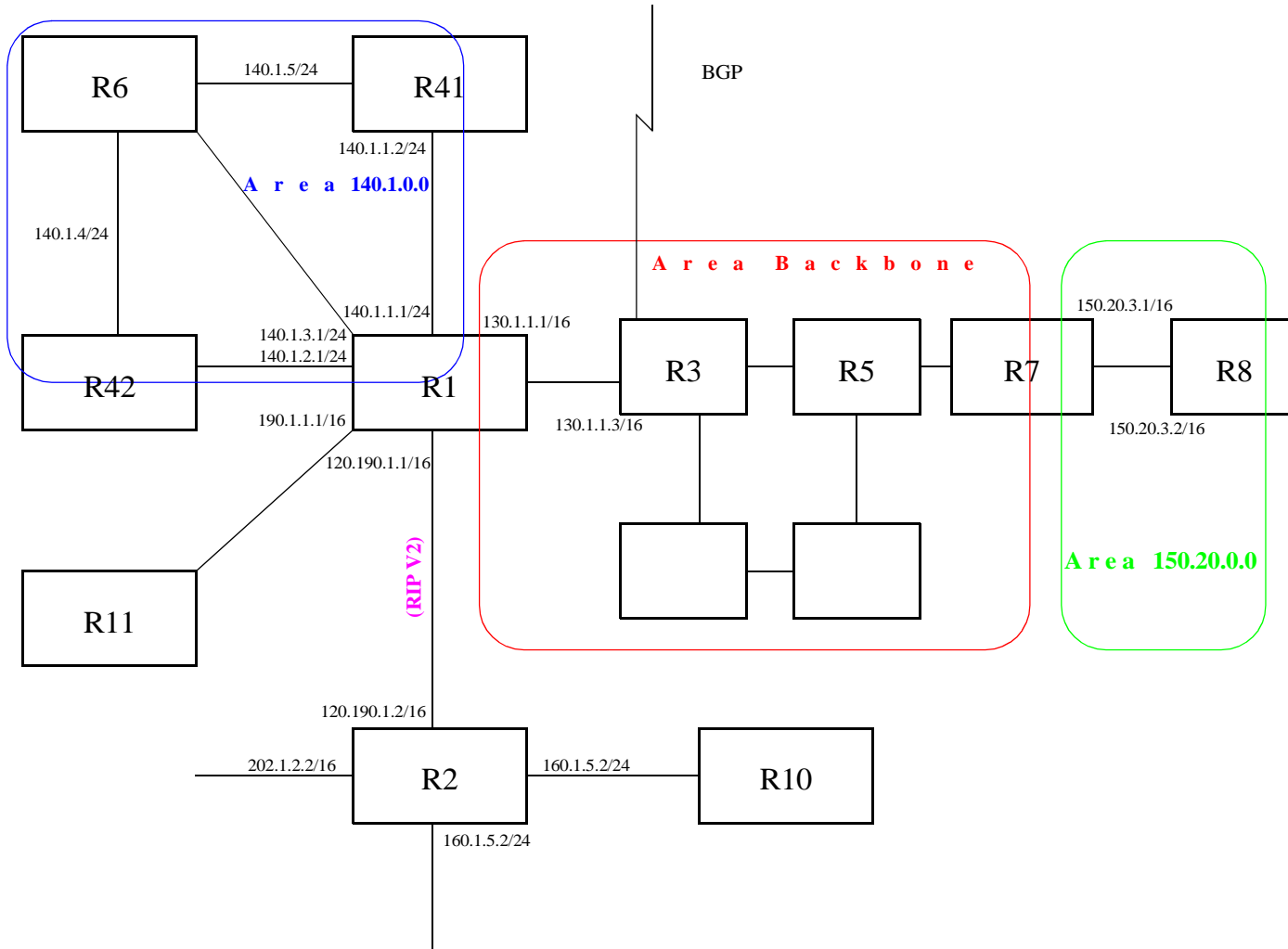

# Chapter 6

# BGP Configuration Guide

## BGP Overview

The Border Gateway Protocol (BGP) is an exterior gateway protocol that allows IP routers to exchange network reachability information. BGP became an internet standard in 1989 (RFC 1105) and the current version, BGP-4, was published in 1994 (RFC 1771). BGP is typically run between Internet Service Providers. It is also frequently used by multi-homed ISP customers, as well as in large commercial networks.

Autonomous systems that wish to connect their networks together must agree on a method of exchanging routing information. Interior gateway protocols such as RIP and OSPF may be inadequate for this task since they were not designed to handle multi-AS, policy, and security issues. Similarly, using static routes may not be the best choice for exchanging AS-AS routing information because there may be a large number of routes, or the routes may change often.

**Note:** This chapter uses the term *Autonomous System* (AS) throughout. An AS is defined as a set of routers under a central technical administration that has a coherent interior routing plan and accurately portrays to other ASs what routing destinations are reachable by way of it.

In an environment where using static routes is not feasible, BGP is often the best choice for an AS-AS routing protocol. BGP prevents the introduction of routing loops created by multi-homed and meshed AS topologies. BGP also provides the ability to create and enforce policies at the AS level, such as selectively determining which AS routes are to be accepted or what routes are to be advertised to BGP peers.

## The SSR BGP Implementation

The SSR routing protocol implementation is based on GateD 4.0.3 code (<http://www.gated.org>). GateD is a modular software program consisting of core services, a routing database, and protocol modules supporting multiple routing protocols (RIP versions 1 and 2, OSPF version 2, BGP version 2 through 4, and Integrated IS-IS).

Since the SSR IP routing code is based upon GateD, BGP can also be configured using a GateD configuration file (`gated.conf`) instead of the SSR Command Line Interface (CLI). Additionally, even if the SSR is configured using the CLI, the `gated.conf` equivalent can be displayed by entering the **ip-router show configuration-file** command at the SSR Enable prompt.

VLANs, interfaces, ACLs, and many other SSR configurable entities and functionality can only be configured using the SSR CLI. Therefore, a `gated.conf` file is dependent upon some SSR CLI configuration.

## Basic BGP Tasks

This section describes the basic tasks necessary to configure BGP on the SSR. Due to the abstract nature of BGP, many BGP designs can be extremely complex. For any one BGP design challenge, there may only be one solution out of many that is relevant to common practice.

When designing a BGP configuration, it may be prudent to refer to information in RFCs, Internet drafts, and books about BGP. Some BGP designs may also require the aid of an experienced BGP network consultant.

Basic BGP configuration involves the following tasks:

- Setting the autonomous system number
- Setting the router ID
- Creating a BGP peer group
- Adding a BGP peer host
- Starting BGP
- Using AS path regular expressions
- Using AS path prepend



## Setting the Autonomous System Number

An autonomous system number identifies your autonomous system to other routers. To set the SSR's autonomous system number, enter the following command in Configure mode.

Set the SSR's autonomous system number	<b>ip-router global set autonomous-system</b> <num1> <b>loops</b> <num2>
--	---

The **autonomous-system** <num1> parameter sets the AS number for the router. Specify a number from 1–65534. The **loops** <num2> parameter controls the number of times the AS may appear in the as-path. The default is 1.

## Setting the Router ID

The router ID uniquely identifies the SSR. To set the router ID to be used by BGP, enter the following command in Configure mode.

Set the SSR's router ID	<b>ip-router global set router-id</b> <hostname-or-IPaddr>
-------------------------	--

If you do not explicitly specify the router ID, then an ID is chosen implicitly by the SSR. A secondary address on the loopback interface (the primary address being 127.0.0.1) is the most preferred candidate for selection as the SSR's router ID. If there are no secondary addresses on the loopback interface, then the default router ID is set to the address of the first interface that is in the up state that the SSR encounters (except the interface en0, which is the Control Module's interface). The address of a non point-to-point interface is preferred over the local address of a point-to-point interface. If the router ID is implicitly chosen to be the address of a non-loopback interface, and if that interface were to go down, then the router ID is changed. When the router ID changes, an OSPF router has to flush all its LSAs from the routing domain.

If you explicitly specify a router ID, then it would not change, even if all interfaces were to go down.

## Configuring a BGP Peer Group

A BGP peer group is a group of neighbor routers that have the same update policies. To configure a BGP peer group, enter the following command in Configure mode:

Configure a BGP peer group	<b>bgp create peer-group</b> <number-or-string> <b>type</b> external   internal   igp   routing [ <b>autonomous-system</b> <number>] [ <b>proto</b> any   rip   ospf   static] [ <b>interface</b> <interface-name-or-ipaddr>   all]
----------------------------	---

where:

**peer-group** <number-or-string>

Is a group ID, which can be a number or a character string.

**type** Specifies the type of BGP group you are adding. You can specify one of the following:

**external** In the classic external BGP group, full policy checking is applied to all incoming and outgoing advertisements. The external neighbors must be directly reachable through one of the machine's local interfaces.

**routing** An internal group which uses the routes of an interior protocol to resolve forwarding addresses. Type Routing groups will determine the immediate next hops for routes by using the next hop received with a route from a peer as a forwarding address, and using this to look up an immediate next hop in an IGP's routes. Such groups support distant peers, but need to be informed of the IGP whose routes they are using to determine immediate next hops. This implementation comes closest to the IBGP implementation of other router vendors.

**internal** An internal group operating where there is no IP-level IGP, for example an SMDS network. Type Internal groups expect all peers to be directly attached to a shared subnet so that, like external peers, the next hops received in BGP advertisements may be used directly for forwarding. All Internal group peers should be L2 adjacent.

**igp** An internal group operating where there is no IP-level IGP; for example, an SMDS network.

**autonomous-system** <number>

Specifies the autonomous system of the peer group. Specify a number from 1 – 65534.

**proto** Specifies the interior protocol to be used to resolve BGP next hops. Specify one of the following:

**any** Use any igp to resolve BGP next hops.

**rip** Use RIP to resolve BGP next hops.

**ospf** Use OSPF to resolve BGP next hops.

**static** Use static to resolve BGP next hops.

**interface** <name-or-IPaddr> | **all**

Interfaces whose routes are carried via the IGP for which third-party next hops may be used instead. Use only for type Routing group. Specify the interface or **all** for all interfaces.

## Adding a BGP Peer

There are two ways to add BGP peers to peer groups. You can explicitly add a peer host, or you can add a network. Adding a network allows for peer connections from any addresses in the range of network and mask pairs specified in the **bgp add network** command.

To add BGP peers to BGP peer groups, enter one of the following commands in Configure mode.

Add a host to a BGP peer group.	<b>bgp add peer-host</b> <ipaddr> <b>group</b> <number-or-string>
Add a network to a BGP peer group.	<b>bgp add network</b> <ip-addr-mask>   <b>all group</b> <number-or-string>

## Starting BGP

BGP is disabled by default. To start BGP, enter the following command in Configure mode.

Start BGP	<b>bgp start</b>
-----------	------------------

## Using AS-Path Regular Expressions

An AS-path regular expression is a regular expression where the alphabet is the set of AS numbers. An AS-path regular expression is composed of one or more AS-path expressions. An AS-path expression is composed of AS path terms and AS-path operators.

An AS path term is one of the following three objects:

autonomous\_system

Is any valid autonomous system number, from one through 65534 inclusive.

.(dot)

Matches any autonomous system number.

( aspath\_regexp )

Parentheses group subexpressions. An operator, such as \* or ? works on a single element or on a regular expression enclosed in parentheses

An AS-path operator is one of the following:

aspath\_term {m,n}

A regular expression followed by {m,n} (where m and n are both non-negative integers and m <= n) means at least m and at most n repetitions.

`aspath_term {m}`  
A regular expression followed by {m} (where m is a positive integer) means exactly m repetitions.

`aspath_term {m,}`  
A regular expression followed by {m,} (where m is a positive integer) means m or more repetitions.

`aspath_term *`  
An AS path term followed by \* means zero or more repetitions. This is shorthand for {0,}.

`aspath_term +`  
A regular expression followed by + means one or more repetitions. This is shorthand for {1,}.

`aspath_term ?`  
A regular expression followed by ? means zero or one repetition. This is shorthand for {0,1}.

`aspath_term | aspath_term`  
Matches the AS term on the left, or the AS term on the right.

For example:

`(4250.*)` Means anything beginning with 4250

`(.* 6301.*)` Means anything with 6301.

`(.* 4250)` Means anything ending with 4250.

`(.* 1104|1125|1888|1135.*)`  
Means anything containing 1104 or 1125 or 1888 or 1135.

AS-path regular expressions are used as one of the parameters for determining which routes are accepted and which routes are advertised.

### AS-Path Regular Expression Examples

To import MCI routes with a preference of 165:

```
ip-router policy create bgp-import-source mciRoutes aspath-regular-  
expression "(.* 3561 .*)" origin any sequence-number 10  
ip-router policy import source mciRoutes network all preference 165
```

To import all routes (\*. \* matches all AS paths) with the default preference:

```
ip-router policy create bgp-import-source allOthers aspath-regular-
  expression "(.*)" origin any sequence-number 20
ip-router policy import source allOthers network all
```

To export all active routes from 284 or 813 or 814 or 815 or 816 or 3369 or 3561 to autonomous system 64800.

```
ip-router policy create bgp-export-destination to-64800 autonomous-
  system 64800
ip-router policy create aspath-export-source allRoutes aspath-regular-
  expression "(.*(284|813|814|815|816|3369|3561) .*)" origin any
  protocol all
ip-router policy export destination to-64800 source allRoutes network
  all
```

## Using the AS Path Prepend Feature

When BGP compares two advertisements of the same prefix that have differing AS paths, the default action is to prefer the path with the lowest number of transit AS hops; in other words, the preference is for the shorter AS path length. The AS path prepend feature is a way to manipulate AS path attributes to influence downstream route selection. AS path prepend involves inserting the originating AS into the beginning of the AS prior to announcing the route to the exterior neighbor.

Lengthening the AS path makes the path less desirable than would otherwise be the case. However, this method of influencing downstream path selection is feasible only when comparing prefixes of the same length because an instance of a more specific prefix always is preferable.

On the SSR, the number of instances of an AS that are put in the route advertisement is controlled by the **as-count** option of the **bgp set peer-host** command.

The following is an example:

```
#
# insert two instances of the AS when advertising the route to this peer
#
bgp set peer-host 194.178.244.33 group nlnet as-count 2
#
# insert three instances of the AS when advertising the route to this
# peer
#
bgp set peer-host 194.109.86.5 group webnet as-count 3
```

### Notes on Using the AS Path Prepend Feature

- Use the **as-count** option for external peer-hosts only.
- If the **as-count** option is entered for an active BGP session, routes will *not* be resent to reflect the new setting. To have routes reflect the new setting, you must restart the peer session. To do this:
  - a. Enter Configure mode.
  - b. Negate the command that adds the peer-host to the peer-group. (If this causes the number of peer-hosts in the peer-group to drop to zero, then you must also negate the command that creates the peer group.)
  - c. Exit Configure mode.
  - d. Re-enter Configure mode.
  - e. Add the peer-host back to the peer-group.

If the **as-count** option is part of the startup configuration, the above steps are unnecessary.

## BGP Configuration Examples

This section presents sample configurations illustrating BGP features. The following features are demonstrated:

- BGP peering
- Internal BGP (IBGP)
- External BGP (EBGP) multihop
- BGP community attribute
- BGP local preference (local\_pref) attribute
- BGP Multi-Exit Discriminator (MED) attribute
- EBGP aggregation
- Route reflection

### BGP Peering Session Example

The router process used for a specific BGP peering session is known as a *BGP speaker*. A single router can have several BGP speakers. Successful BGP peering depends on the establishment of a neighbor relationship between BGP speakers. The first step in creating

a BGP neighbor relationship is the establishment of a TCP connection (using TCP port 179) between peers.

A BGP Open message can then be sent between peers across the TCP connection to establish various BGP variables (BGP Version, AS number (ASN), hold time, BGP identifier, and optional parameters). Upon successful completion of the BGP Open negotiations, BGP Update messages containing the BGP routing table can be sent between peers.

BGP does not require a periodic refresh of the entire BGP routing table between peers. Only incremental routing changes are exchanged. Therefore, each BGP speaker is required to retain the entire BGP routing table of their peer for the duration of the peer's connection.

BGP "keepalive" messages are sent between peers periodically to ensure that the peers stay connected. If one of the routers encounter a fatal error condition, a BGP notification message is sent to its BGP peer and the TCP connection is closed.

Figure 2 illustrates a sample BGP peering session.

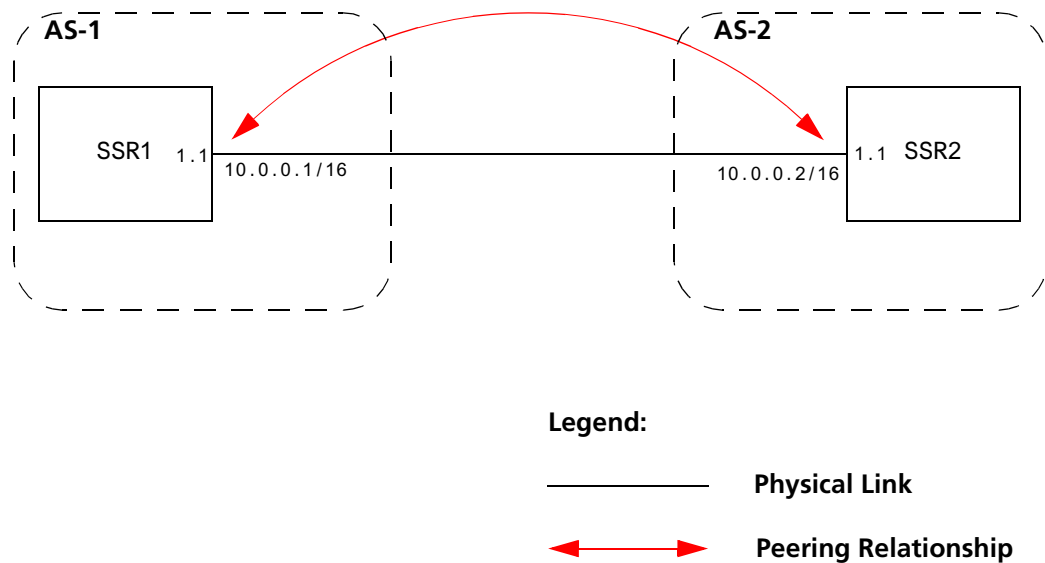

Figure 2. Sample BGP Peering Session

The CLI configuration for router SSR1 is as follows:

```
interface create ip et.1.1 address-netmask 10.0.0.1/16 port et.1.1
#
# Set the AS of the router
#
ip-router global set autonomous-system 1
#
# Set the router ID
#
ip-router global set router-id 10.0.0.1
#
# Create EBGp peer group pg1w2 for peering with AS 2
#
bgp create peer-group pg1w2 type external autonomous-system 2
#
# Add peer host 10.0.0.2 to group pg1w2
#
bgp add peer-host 10.0.0.2 group pg1w2
bgp start
```

The gated.conf file for router SSR1 is as follows:

```
autonomoussystem 1 ;
routerid 10.0.0.1 ;
bgp yes {
    group type external peeras 2
    {
        peer 10.0.0.2
    }
};
};
```

The CLI configuration for router SSR2 is as follows:

```
interface create ip et.1.1 address-netmask 10.0.0.2/16 port et.1.1
ip-router global set autonomous-system 2
ip-router global set router-id 10.0.0.2
bgp create peer-group pg2w1 type external autonomous-system 1
bgp add peer-host 10.0.0.1 group pg2w1
bgp start
```



The gated.conf file for router SSR2 is as follows:

```

autonomoussystem 2 ;
routerid 10.0.0.2 ;
bgp yes {
    group type external peeras 1
    {
        peer 10.0.0.1
    };
};

```

## IBGP Configuration Example

Connections between BGP speakers within the same AS are referred to as internal links. A peer in the same AS is an internal peer. Internal BGP is commonly abbreviated IBGP; external BGP is EBGP.

An AS that has two or more EBGP peers is referred to as a multihomed AS. A multihomed AS can “transit” traffic between two ASs by advertising to one AS routes that it learned from the other AS. To successfully provide transit services, all EBGP speakers in the transit AS must have a consistent view of all of the routes reachable through their AS.

Multihomed transit ASs can use IBGP between EBGP-speaking routers in the AS to synchronize their routing tables. IBGP requires a full-mesh configuration; all EBGP speaking routers must have an IBGP peering session with every other EBGP speaking router in the AS.

An IGP, like OSPF, could possibly be used instead of IBGP to exchange routing information between EBGP speakers within an AS. However, injecting full Internet routes (50,000+ routes) into an IGP puts an expensive burden on the IGP routers. Additionally, IGPs cannot communicate all of the BGP attributes for a given route. It is therefore recommended that an IGP not be used to propagate full Internet routes between EBGP speakers. IBGP should be used instead.

## IBGP Routing Group Example

An IBGP Routing group uses the routes of an interior protocol to resolve forwarding addresses. An IBGP Routing group will determine the immediate next hops for routes by using the next hop received with a route from a peer as a forwarding address, and using this to look up an immediate next hop in an IGP’s routes. Such groups support distant peers, but need to be informed of the IGP whose routes they are using to determine immediate next hops. This implementation comes closest to the IBGP implementation of other router vendors.

You should use the IBGP Routing group as the mechanism to configure the SSR for IBGP. If the peers are directly connected, then IBGP using group-type Internal can also be used.

Note that for running IBGP using group-type Routing you must run an IGP such as OSPF to resolve the next hops that come with external routes. You could also use protocol **any** so that all protocols are eligible to resolve the BGP forwarding address.

Figure 3 shows a sample BGP configuration that uses the Routing group type.

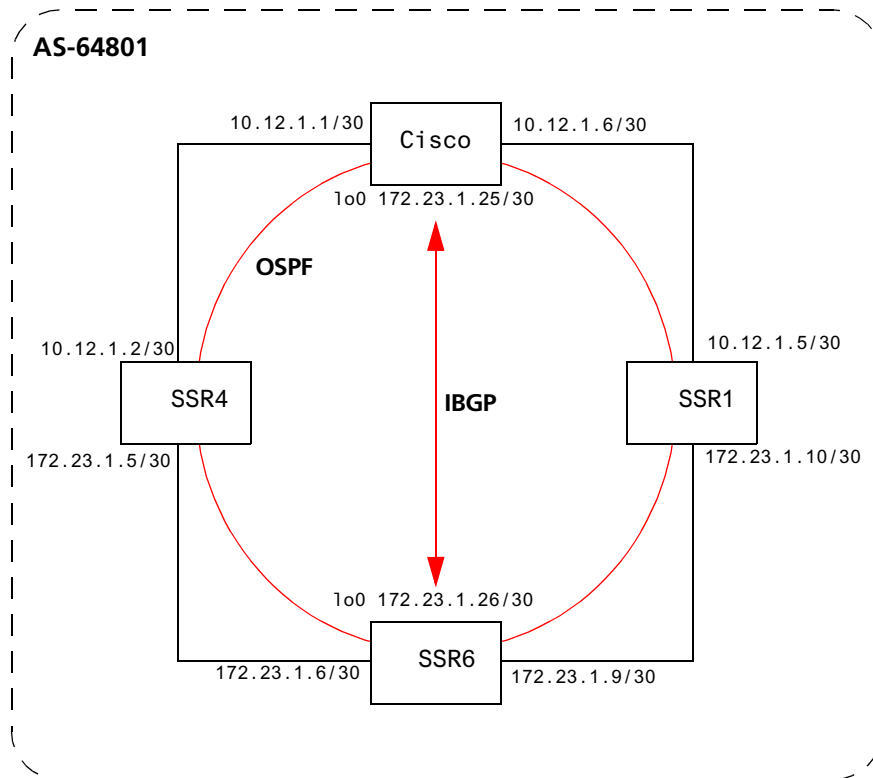

Figure 3. Sample IBGP Configuration (Routing Group Type)

In this example, OSPF is configured as the IGP in the autonomous system. The following lines in the router SSR6 configuration file configure OSPF:

```
#
# Create a secondary address for the loopback interface
#
interface add ip lo0 address-netmask 172.23.1.26/30
ospf create area backbone
ospf add interface to-SSR4 to-area backbone
ospf add interface to-SSR1 to-area backbone
#
# This line is necessary because we want CISCO to peer with our loopback
# address.This will make sure that the loopback address gets announced
# into OSPF domain
#
ospf add stub-host 172.23.1.26 to-area backbone cost 1
ospf set interface to-SSR4 priority 2
ospf set interface to-SSR1 priority 2
ospf set interface to-SSR4 cost 2
ospf start
```

The following lines in the Cisco router configure OSPF:

```
The following lines on the CISCO 4500 configures it for OSPF.
router ospf 1
 network 10.12.1.1 0.0.0.0 area 0
 network 10.12.1.6 0.0.0.0 area 0
 network 172.23.1.14 0.0.0.0 area 0
```

The following lines in the SSR6 set up peering with the Cisco router using the Routing group type.

```
# Create a internal routing group.
bgp create peer-group ibgp1 type routing autonomous-system 64801 proto any
interface all
# Add CISCO to the above group
bgp add peer-host 172.23.1.25 group ibgp1
# Set our local address. This line is necessary because we want CISCO to
# peer with our loopback
bgp set peer-group ibgp1 local-address 172.23.1.26
# Start BGP
bgp start
```

The following lines on the Cisco router set up IBGP peering with router SSR6.

```
router bgp 64801
!
! Disable synchronization between BGP and IGP
!
no synchronization
neighbor 172.23.1.26 remote-as 64801
!
! Allow internal BGP sessions to use any operational interface for TCP
! connections
!
neighbor 172.23.1.26 update-source Loopback0
```

### IBGP Internal Group Example

The IBGP Internal group expects all peers to be directly attached to a shared subnet so that, like external peers, the next hops received in BGP advertisements may be used directly for forwarding. All Internal group peers should be L2 adjacent.

Figure 4 illustrates a sample IBGP Internal group configuration.

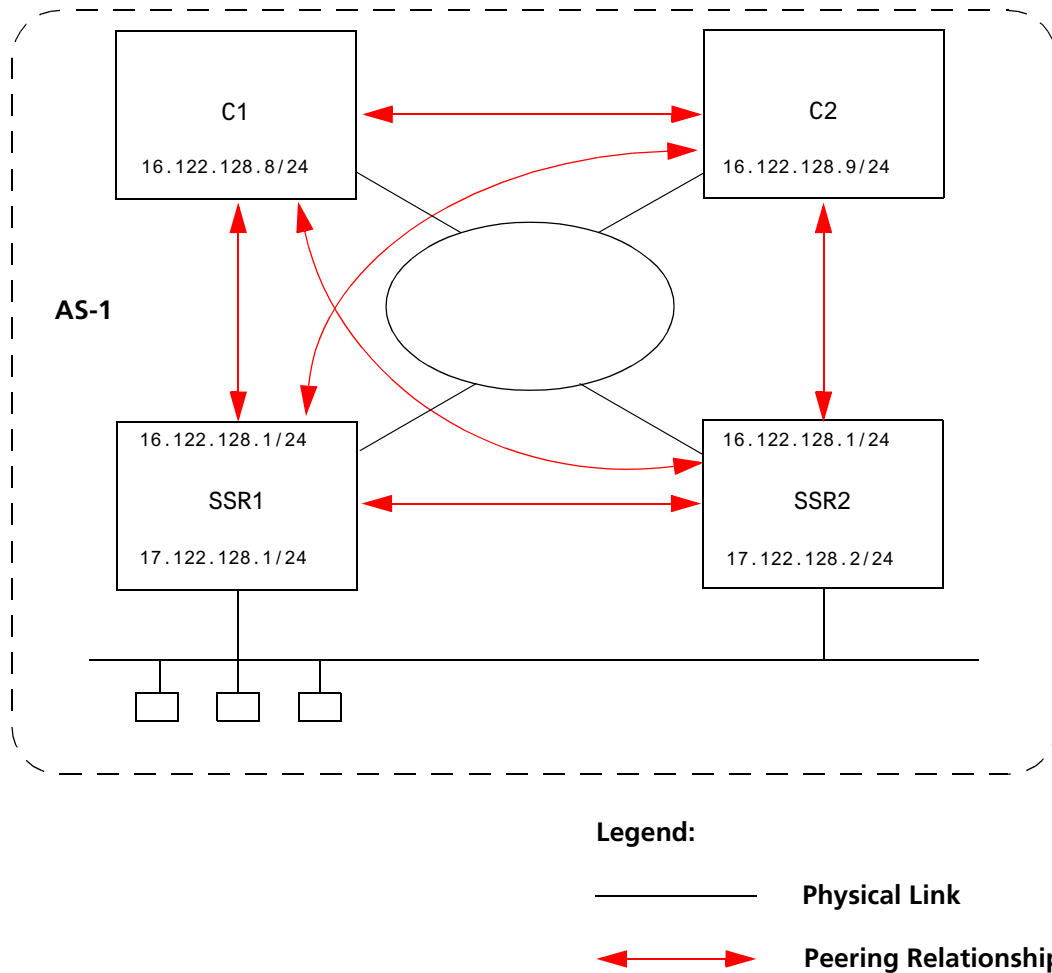

**Figure 4. Sample IBGP Configuration (Internal Group Type)**

The CLI configuration for router SSR1 is as follows:

```
ip-router global set autonomous-system 1
bgp create peer-group int-ibgp-1 type internal autonomous-system 1
bgp add peer-host 16.122.128.2 group int-ibgp-1
bgp add peer-host 16.122.128.8 group int-ibgp-1
bgp add peer-host 16.122.128.9 group int-ibgp-1
```

The gated.conf file for router SSR1 is as follows:

```
autonomoussystem 1 ;
routerid 16.122.128.1 ;

bgp yes {
    traceoptions aspath detail packets detail open detail update ;

    group type internal peeras 1
    {
        peer 16.122.128.2
        ;
        peer 16.122.128.8
        ;
        peer 16.122.128.9
        ;
    }
};
```

The CLI configuration for router SSR2 is as follows:

```
ip-router global set autonomous-system 1
bgp create peer-group int-ibgp-1 type internal autonomous-system 1
bgp add peer-host 16.122.128.1 group int-ibgp-1
bgp add peer-host 16.122.128.8 group int-ibgp-1
bgp add peer-host 16.122.128.9 group int-ibgp-1
```

The gated.conf file for router SSR2 is as follows:

```
autonomoussystem 1 ;
routerid 16.122.128.2 ;

bgp yes {
    traceoptions aspath detail packets detail open detail update ;

    group type internal peeras 1
    {
        peer 16.122.128.1
        ;
        peer 16.122.128.8
        ;
        peer 16.122.128.9
        ;
    }
};
```

The configuration for router C1 (a Cisco router) is as follows:

```
router bgp 1
  no synchronization
  network 16.122.128.0 mask 255.255.255.0
  network 17.122.128.0 mask 255.255.255.0
  neighbor 16.122.128.1 remote-as 1
  neighbor 16.122.128.1 next-hop-self
  neighbor 16.122.128.1 soft-reconfiguration inbound
  neighbor 16.122.128.2 remote-as 1
  neighbor 16.122.128.2 next-hop-self
  neighbor 16.122.128.2 soft-reconfiguration inbound
  neighbor 16.122.128.9 remote-as 1
  neighbor 16.122.128.9 next-hop-self
  neighbor 16.122.128.9 soft-reconfiguration inbound
  neighbor 18.122.128.4 remote-as 4
```

The configuration for router C2 (a Cisco router) is as follows:

```
router bgp 1
  no synchronization
  network 16.122.128.0 mask 255.255.255.0
  network 17.122.128.0 mask 255.255.255.0
  neighbor 14.122.128.5 remote-as 5
  neighbor 16.122.128.1 remote-as 1
  neighbor 16.122.128.1 next-hop-self
  neighbor 16.122.128.1 soft-reconfiguration inbound
  neighbor 16.122.128.2 remote-as 1
  neighbor 16.122.128.2 next-hop-self
  neighbor 16.122.128.2 soft-reconfiguration inbound
  neighbor 16.122.128.8 remote-as 1
  neighbor 16.122.128.8 next-hop-self
  neighbor 16.122.128.8 soft-reconfiguration inbound
```

## EBGP Multihop Configuration Example

EBGP Multihop refers to a configuration where external BGP neighbors are not connected to the same subnet. Such neighbors are logically, but not physically connected. For example, BGP can be run between external neighbors across non-BGP routers. Some additional configuration is required to indicate that the external peers are not physically attached.

This sample configuration shows External BGP peers, SSR1 and SSR4, which are not connected to the same subnet.

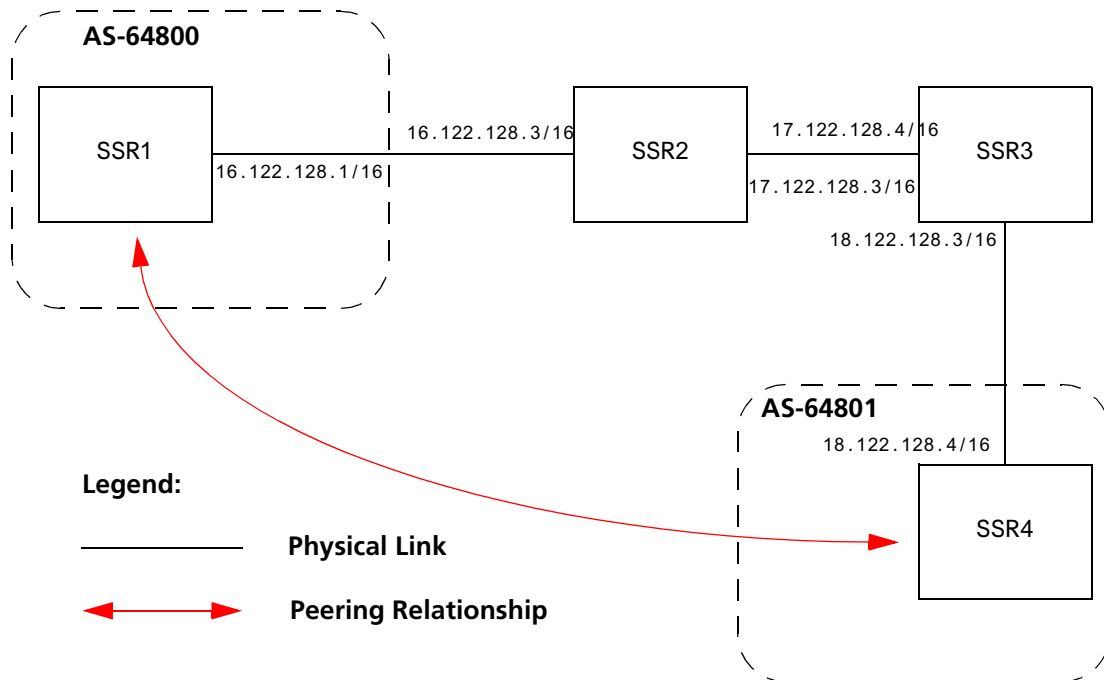

The CLI configuration for router SSR1 is as follows:

```

bgp create peer-group ebgp_multihop autonomous-system 64801 type external
bgp add peer-host 18.122.128.2 group ebgp_multihop
!
! Specify the gateway option which indicates EBGP multihop. Set the
! gateway option to the address of the router that has a route to the
! peer.
!
bgp set peer-host 18.122.128.2 gateway 16.122.128.3 group ebgp_multihop

```



The gated.conf file for router SSR1 is as follows:

```

autonomoussystem 64800 ;

routerid 0.0.0.1 ;

bgp yes {
    traceoptions state ;

    group type external peeras 64801
    {
        peer 18.122.128.2
            gateway 16.122.128.3
            ;
    };
};

static {
    18.122.0.0 masklen 16
        gateway 16.122.128.3
        ;
};

```

The CLI configuration for router SSR2 is as follows:

```

interface create ip to-R1 address-netmask 16.122.128.3/16 port et.1.1
interface create ip to-R3 address-netmask 17.122.128.3/16 port et.1.2
#
# Static route needed to reach 18.122.0.0/16
#
ip add route 18.122.0.0/16 gateway 17.122.128.4

```

The gated.conf file for router SSR2 is as follows:

```

static {
    18.122.0.0 masklen 16
        gateway 17.122.128.4
        ;
};

```

The CLI configuration for router SSR3 is as follows:

```

interface create ip to-yago3 address-netmask 17.122.128.4/16 port et.4.2
interface create ip to-yago2 address-netmask 18.122.128.4/16 port et.4.4
ip add route 16.122.0.0/16 gateway 17.122.128.3

```

The gated.conf file for router SSR3 is as follows:

```
static {
    16.122.0.0 masklen 16
        gateway 17.122.128.3
    ;
};
```

The CLI configuration for router SSR4 is as follows:

```
bgp create peer-group ebgp_multihop autonomous-system 64801 type external
bgp add peer-host 18.122.128.2 group ebgp_multihop
!
! Specify the gateway option which indicates EBGP multihop. Set the
! gateway option to the address of the router that has a route to the
! peer.
!
bgp set peer-host 18.122.128.2 gateway 16.122.128.3 group ebgp_multihop
```

The gated.conf file for router SSR4 is as follows:

```
autonomoussystem 64800 ;

routerid 0.0.0.1 ;

bgp yes {
    traceoptions state ;

    group type external peeras 64801
    {
        peer 18.122.128.2
            gateway 16.122.128.3
```

## Community Attribute Example

The following configuration illustrates the BGP community attribute. Community is specified as one of the parameters in the **optional attributes list** option of the **ip-router policy create** command.

[Figure 5](#) shows a BGP configuration where the specific community attribute is used. [Figure 6](#) shows a BGP configuration where the well-known community attribute is used.

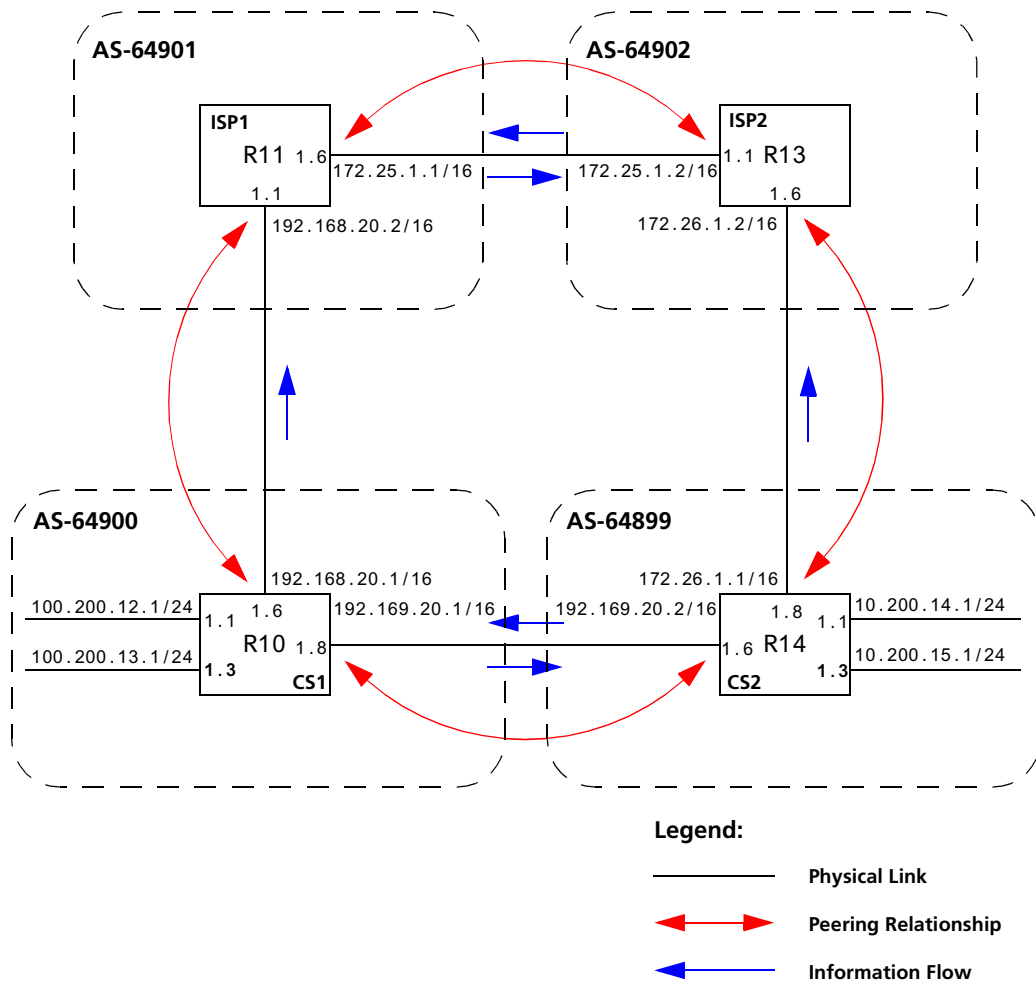

Figure 5. Sample BGP Configuration (Specific Community)

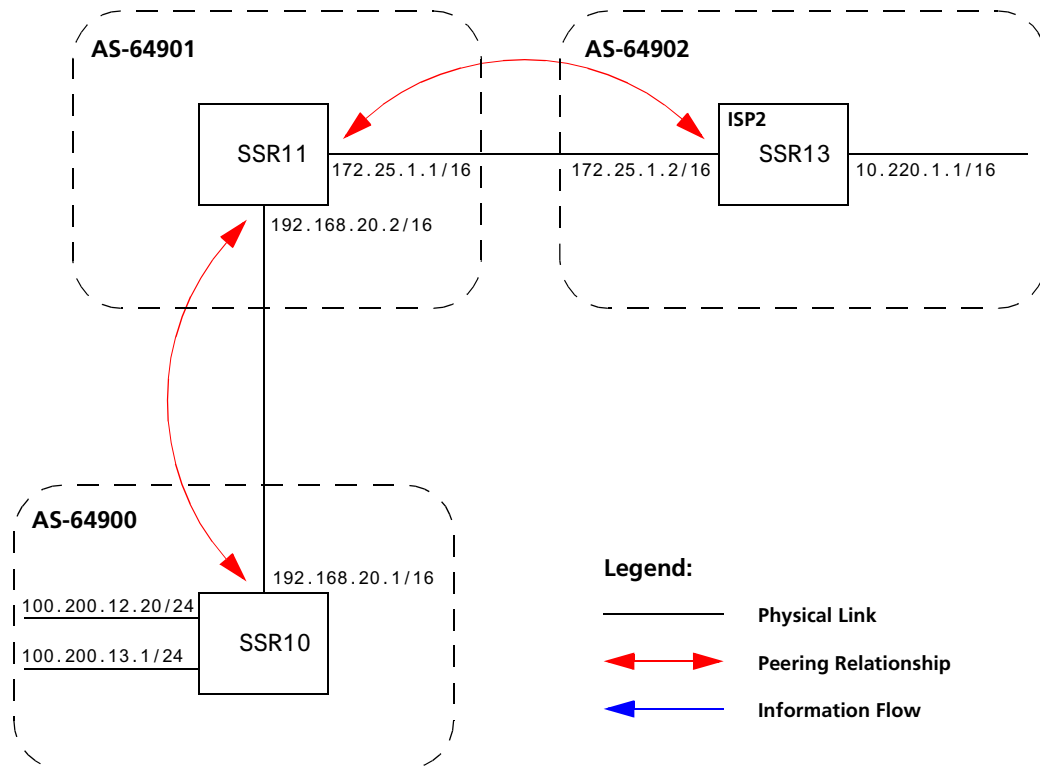

Figure 6. Sample BGP Configuration (Well-Known Community)

The Community attribute can be used in three ways:

1. In a BGP Group statement: Any packets sent to this group of BGP peers will have the communities attribute in the BGP packet modified to be this communities attribute value from this AS.
2. In an Import Statement: Any packets received from a BGP peer will be checked for the community attribute. The **optional-attributes-list** option of the **ip-router policy create** command allows the specification of an import policy based on optional path attributes (for instance, the community attribute) found in the BGP update. If multiple communities are specified in the **optional-attributes-list** option, only updates carrying all of the specified communities will be matched. If **well-known-community none** is specified, only updates lacking the community attribute will be matched.

Note that it is quite possible for several BGP import clauses to match a given update. If more than one clause matches, the first matching clause will be used; all later matching clauses will be ignored. For this reason, it is generally desirable to order import clauses from most to least specific. An import clause without an **optional-attributes-list** option will match any update with any (or no) communities.

In [Figure 6](#), router SSR11 has the following configuration:

```
#
# Create an optional attribute list with identifier color1 for a community
# attribute (community-id 160 AS 64901)
#
ip-router policy create optional-attributes-list color1 community-id 160
    autonomous-system 64901
#
# Create an optional attribute list with identifier color2 for a community
# attribute (community-id 155 AS 64901)
#
ip-router policy create optional-attributes-list color2 community-id 155
    autonomous-system 64901
#
# Create a BGP import source for importing routes from AS 64900 containing the
# community attribute (community-id 160 AS 64901). This import source is given an
# identifier 901color1 and sequence-number 1.
#
ip-router policy create bgp-import-source 901color1 optional-attributes-list
    color1 autonomous-system 64900 sequence-number 1
ip-router policy create bgp-import-source 901color2 optional-attributes-list
    color2 autonomous-system 64900 sequence-number 2
ip-router policy create bgp-import-source 901color3 optional-attributes-list
    color1 autonomous-system 64902 sequence-number 3
ip-router policy create bgp-import-source 901color4 optional-attributes-list
    color2 autonomous-system 64902 sequence-number 4
#
# Import all routes matching BGP import source 901color1 (from AS 64900 having
# community attribute with ID 160 AS 64901) with a preference of 160
#
ip-router policy import source 901color1 network all preference 160
ip-router policy import source 901color2 network all preference 155
ip-router policy import source 901color3 network all preference 160
ip-router policy import source 901color4 network all preference 155
```

In [Figure 6](#), router SSR13 has the following configuration:

```
ip-router policy create optional-attributes-list color1 community-id 160
  autonomous-system 64902
ip-router policy create optional-attributes-list color2 community-id 155
  autonomous-system 64902
ip-router policy create bgp-import-source 902color1 optional-attributes-list
  color1 autonomous-system 64899 sequence-number 1
ip-router policy create bgp-import-source 902color2 optional-attributes-list
  color2 autonomous-system 64899 sequence-number 2
ip-router policy create bgp-import-source 902color3 optional-attributes-list
  color1 autonomous-system 64901 sequence-number 3
ip-router policy create bgp-import-source 902color4 optional-attributes-list
  color2 autonomous-system 64901 sequence-number 4
ip-router policy import source 902color1 network all preference 160
ip-router policy import source 902color2 network all preference 155
ip-router policy import source 902color3 network all preference 160
ip-router policy import source 902color4 network all preference 155
```

3. In an Export Statement: The **optional-attributes-list** option of the **ip-router policy create bgp-export-destination** command may be used to send the BGP community attribute. Any communities specified with the **optional-attributes-list** option are sent in addition to any received in the route or specified with the group.

In [Figure 6](#), router SSR10 has the following configuration:

```
#
# Create an optional attribute list with identifier color1 for a community
# attribute (community-id 160 AS 64902)
#
ip-router policy create optional-attributes-list color1 community-id 160
    autonomous-system 64902
#
# Create an optional attribute list with identifier color2 for a community
# attribute (community-id 155 AS 64902)
#
ip-router policy create optional-attributes-list color2 community-id 155
    autonomous-system 64902
#
# Create a direct export source
#
ip-router policy create direct-export-source 900toanydir metric 10
#
# Create BGP export-destination for exporting routes to AS 64899 containing the
# community attribute (community-id 160 AS 64902). This export-destination has an
# identifier 900to899dest
#
ip-router policy create bgp-export-destination 900to899dest autonomous-system
    64899 optional-attributes-list color1
ip-router policy create bgp-export-destination 900to901dest autonomous-system
    64901 optional-attributes-list color2
#
# Export routes to AS 64899 with the community attribute (community-id 160 AS
# 64902)
#
ip-router policy export destination 900to899dest source 900toanydir network all
ip-router policy export destination 900to901dest source 900toanydir network all
```

In [Figure 6](#), router SSR14 has the following configuration:

```
ip-router policy create bgp-export-destination 899to900dest autonomous-system
    64900 optional-attributes-list color1
ip-router policy create bgp-export-destination 899to902dest autonomous-system
    64902 optional-attributes-list color2
ip-router policy create bgp-export-source 900toany autonomous-system 64900 metric
    10
ip-router policy create optional-attributes-list color1 community-id 160
    autonomous-system 64901
ip-router policy create optional-attributes-list color2 community-id 155
    autonomous-system 64901
ip-router policy export destination 899to900dest source 899toanydir network all
ip-router policy export destination 899to902dest source 899toanydir network all
```

Any communities specified with the **optional-attributes-list** option are sent in addition to any received with the route or associated with a BGP export destination.

The community attribute may be a single community or a set of communities. A maximum of 10 communities may be specified.

The community attribute can take any of the following forms:

- Specific community

The specific community consists of the combination of the AS-value and community ID.

- Well-known-community no-export

Well-known-community no-export is a special community which indicates that the routes associated with this attribute must not be advertised outside a BGP confederation boundary. Since the SSR's implementation does not support Confederations, this boundary is an AS boundary.

For example, router SSR10 in [Figure 6](#) has the following configuration:

```
ip-router policy create optional-attributes-list noexport well-known-
community no-export
ip-router policy create bgp-export-destination 900to901dest autonomous-
system 64901 optional-attributes-list noexport
ip-router policy export destination 900to901dest source 900to901src
network all
ip-router policy export destination 900to901dest source 900to901dir
network all
```

- Well-known-community no-advertise

Well-known-community no-advertise is a special community indicating that the routes associated with this attribute must not be advertised to other bgp peers. A packet can be modified to contain this attribute and passed to its neighbor. However, if a packet is received with this attribute, it cannot be transmitted to another BGP peer.

- Well-known-community no-export-subconfed

Well-known-community no-export-subconfed is a special community indicating the routes associated with this attribute must not be advertised to external BGP peers. (This includes peers in other members' autonomous systems inside a BGP confederation.)

A packet can be modified to contain this attribute and passed to its neighbor. However, if a packet is received with this attribute, the routes (prefix-attribute pair) cannot be advertised to an external BGP peer.

- Well-known-community none

This is not actually a community, but rather a keyword that specifies that a received BGP update is only to be matched if no communities are present. It has no effect when originating communities.



## Notes on Using Communities

When originating BGP communities, the set of communities that is actually sent is the union of the communities received with the route (if any), those specified in group policy (if any), and those specified in export policy (if any).

When receiving BGP communities, the update is only matched if all communities specified in the **optional-attributes-list** option of the **ip-router policy create** command are present in the BGP update. (If additional communities are also present in the update, it will still be matched.)

## Local\_Pref Attribute Example

[Figure 7](#) shows a BGP configuration that uses the BGP local preference (Local\_Pref) attribute in a sample BGP configuration with two autonomous systems.

The local preference is not set directly in the CLI, but rather is a function of the GateD preference and setpref metric. The setpref option allows GateD to set the local preference to reflect GateD's own internal preference for the route, as given by the global protocol preference value. The setpref option may be used with routing or internal type groups. BGP routes with a larger Local\_Pref are preferred.

The formula used to compute the local preference is as follows:

$$\text{Local\_Pref} = 254 - (\text{global protocol preference for this route}) + \text{set preference metric}$$

**Note:** A value greater than 254 will be reset to 254. GateD will only send Local\_Pref values between 0 and 254.

In a mixed GateD and non-GateD network, the non-GateD IBGP implementation may send Local\_Pref values that are greater than 254. When operating a mixed network of this type, you should make sure that all routers are restricted to sending Local\_Pref values in the range metric to 254.

In the sample network in [Figure 7](#), all the traffic exits Autonomous System 64901 through the link between router SSR13 and router SSR11. This is accomplished by setting the Local\_Pref attribute.

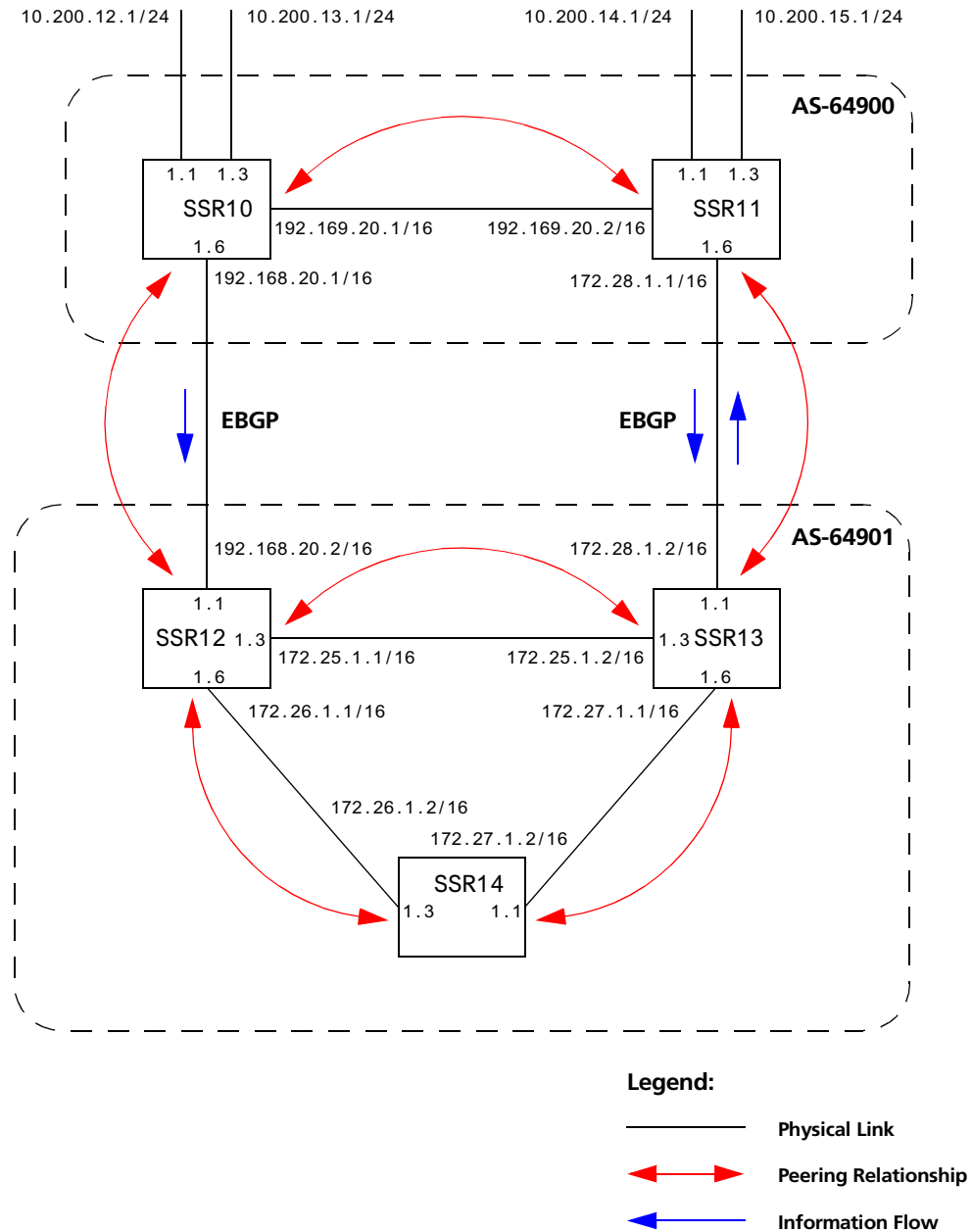

Figure 7. Sample BGP Configuration (Local\_Pref Attribute)

In router SSR12's CLI configuration file, the import preference is set to 160:

```
#
# Set the set-pref metric for the IBGP peer group
#
bgp set peer-group as901 set-pref 100
ip-router policy create bgp-import-source as900 autonomous-system 64900
  preference 160
```

Using the formula for local preference [Local\_Pref = 254 - (global protocol preference for this route) + metric], the Local\_Pref value put out by router SSR12 is 254 - 160+100 = 194

For router SSR13, the import preference is set to 150. The Local\_Pref value put out by router SSR12 is 254 - 160+100 = 204.

```
ip-router policy create bgp-import-source as900 autonomous-system 64900
  preference 150
```

### Notes on Using the Local\_Pref Attribute

- All routers in the same network that are running GateD and participating in IBGP should use the setpref metric, and the setpref metric should be set to the same value.

For example, in [Figure 7](#), routers SSR12, SSR13, and SSR14 have the following line in their CLI configuration files:

```
bgp set peer-group as901 set-pref 100
```

- The value of the setpref metric should be consistent with the import policy in the network.

The metric value should be set high enough to avoid conflicts between BGP routes and IGP or static routes. For example, if the import policy sets GateD preferences ranging from 170 to 200, a setpref metric of 170 would make sense. You should set the metric high enough to avoid conflicts between BGP routes and IGP or static routes.

## Multi-Exit Discriminator Attribute Example

Multi-Exit Discriminator (MED) is a BGP attribute that affects the route selection process. MED is used on external links to discriminate among multiple exit or entry points to the same neighboring AS. All other factors being equal, the exit or entry point with a lower metric should be preferred. If received over external links, the MED attribute may be propagated over internal links to other BGP speakers within the same AS. The MED attribute is never propagated to other BGP speakers in neighboring autonomous systems.

[Figure 8](#) shows a sample BGP configuration where the MED attribute has been used.

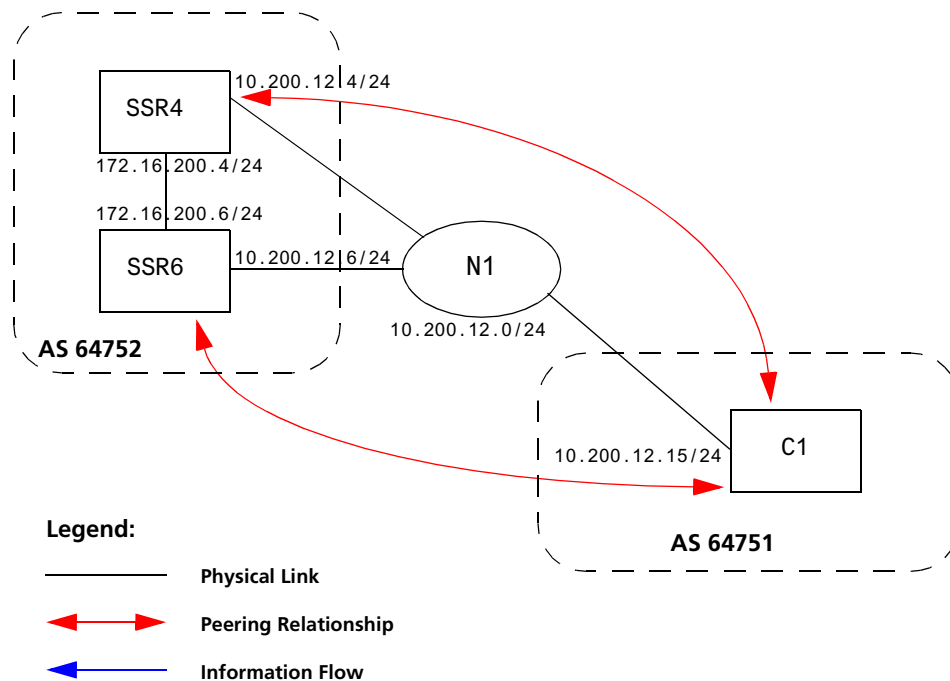

**Figure 8. Sample BGP Configuration (MED Attribute)**

Routers SSR4 and SSR6 inform router C1 about network 172.16.200.0/24 through External BGP (EBGP). Router SSR6 announced the route with a MED of 10, whereas router SSR4 announces the route with a MED of 20. Of the two EBGP routes, router C1 chooses the one with a smaller MED. Thus router C1 prefers the route from router SSR6, which has a MED of 10.

Router SSR4 has the following CLI configuration:

```
bgp create peer-group pg752to751 type external autonomous-system 64751
bgp add peer-host 10.200.12.15 group pg752to751
#
# Set the MED to be announced to peer group pg752to751
#
bgp set peer-group pg752to751 metric-out 20
```

Router SSR6 has the following CLI configuration:

```
bgp create peer-group pg752to751 type external autonomous-system 64751
bgp add peer-host 10.200.12.15 group pg752to751
bgp set peer-group pg752to751 metric-out 10
```

## EBGP Aggregation Example

Figure 9 shows a simple EBGP configuration in which one peer is exporting an aggregated route to its upstream peer and restricting the advertisement of contributing routes to the same peer. The aggregated route is 212.19.192.0/19.

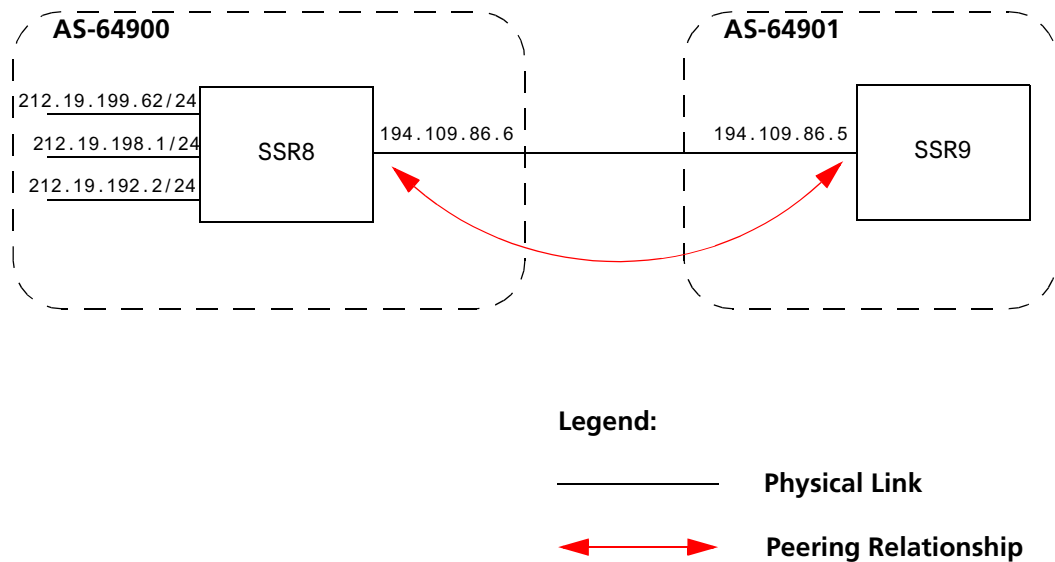

Figure 9. Sample BGP Configuration (Route Aggregation)

Router SSR8 has the following CLI configuration:

```
interface add ip xleapn1 address-netmask 212.19.192.2/24
interface create ip hobbygate address-netmask 212.19.199.62/24 port
  et.1.2
interface create ip xenosite address-netmask 212.19.198.1/24 port
  et.1.7
interface add ip lo0 address-netmask 212.19.192.1/30
bgp create peer-group webnet type external autonomous system 64901
bgp add peer-host 194.109.86.5 group webnet
#
# Create an aggregate route for 212.19.192.0/19 with all its subnets as
# contributing routes
#
ip-router policy summarize route 212.19.192.0/19
ip-router policy redistribute from-proto aggregate to-proto bgp target-
  as 64901 network 212.19.192.0/19
ip-router policy redistribute from-proto direct to-proto bgp target-as
  64901 network all restrict
```

Router SSR9 has the following CLI configuration:

```
bgp create peer-group rtr8 type external autonomous system 64900
bgp add peer-host 194.109.86.6 group rtr8
```

## Route Reflection Example

In some ISP networks, the internal BGP mesh becomes quite large and the IBGP full mesh does not scale well. For such situations, route reflection provides a way to alleviate the need for a full IBGP mesh. In route reflection, the clients peer with the route reflector and exchange routing information with it. In turn, the route reflector passes on (reflects) information between clients.

The IBGP peers of the route reflector fall under two categories: clients and non-clients. A route reflector and its clients form a cluster. All peers of the route reflector that are not part of the cluster are non-clients. The SSR supports client peers as well as non-client peers of a route reflector.

Figure 10 shows a sample configuration that uses route reflection.

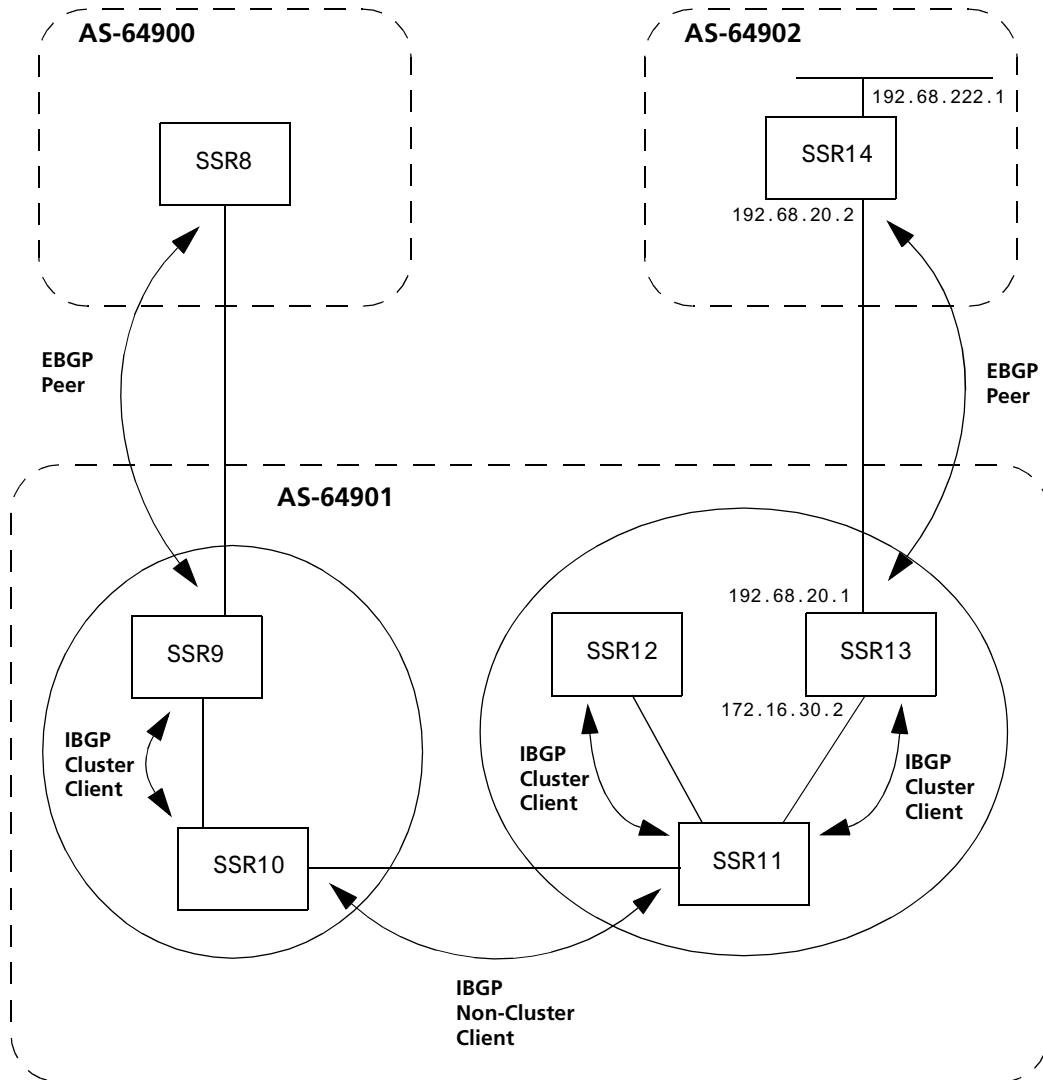

Figure 10. Sample BGP Configuration (Route Reflection)

In this example, there are two clusters. Router SSR10 is the route reflector for the first cluster and router SSR11 is the route reflector for the second cluster. Router SSR10 has router SSR9 as a client peer and router SSR11 as a non-client peer.

The following line in router SSR10's configuration file causes it to be a route reflector.

```
bgp set peer-group SSR9 reflector-client
```

Router SSR11 has router SSR12 and router SSR13 as client peers and router SSR10 as non-client peer. The following line in router SSR11's configuration file specifies it to be a route reflector

```
bgp set peer-group rtr11 reflector-client
```

Even though the IBGP Peers are not fully meshed in AS 64901, the direct routes of router SSR14, that is, 192.68.222.0/24 in AS 64902 (which are redistributed in BGP) do show up in the route table of router SSR8 in AS64900, as shown below:

```
*****
* Route Table (FIB) of Router 8                *
*****
rtr-8# ip show routes

Destination          Gateway                Owner      Netif
-----
10.50.0.0/16         directly connected     -          en
127.0.0.0/8          127.0.0.1             Static     lo
127.0.0.1            127.0.0.1             -          lo
172.16.20.0/24       directly connected     -          m1s1
172.16.70.0/24       172.16.20.2           BGP        m1s1
172.16.220.0/24      172.16.20.2           BGP        m1s1
192.68.11.0/24       directly connected     -          m1s0
192.68.20.0/24       172.16.20.2           BGP        m1s1
192.68.222.0/24      172.16.20.2           BGP        m1s1
```

The direct routes of router SSR8, i.e. 192.68.11.0/24 in AS64900 (which are redistributed in BGP), do show up in the route table of router SSR14 in AS64902, as shown below:

```
*****
* Route Table (FIB) of Router 14              *
*****
rtr-14# ip show routes

Destination          Gateway                Owner      Netif
-----
10.50.0.0/16         directly connected     -          en0
127.0.0.0/8          127.0.0.1             Static     lo0
127.0.0.1            127.0.0.1             -          lo0
172.16.20.0/24       192.68.20.1           BGP        m1s1
172.16.30.0/24       192.68.20.1           BGP        m1s1
172.16.90.0/24       192.68.20.1           BGP        m1s1
192.68.11.0/24       192.68.20.1           BGP        m1s1
192.68.20.0/24       directly connected     -          m1s1
192.68.222.0/24      directly connected     -          m1s0
```



## Notes on Using Route Reflection

- Two types of route reflection are supported:
  - By default, all routes received by the route reflector from a client are sent to all internal peers (including the client's group, but not the client itself).
  - If the **no-client-reflect** option is enabled, routes received from a route reflection client are sent only to internal peers that are not members of the client's group. In this case, the client's group must itself be fully meshed.

In either case, all routes received from a non-client internal peer are sent to all route reflection clients.

- Typically, a single router acts as the reflector for a cluster of clients. However, for redundancy, two or more may also be configured to be reflectors for the same cluster. In this case, a cluster ID should be selected to identify all reflectors serving the cluster, using the **clusterid** option. Gratuitous use of multiple redundant reflectors is not advised, since it can lead to an increase in the memory required to store routes on the redundant reflectors' peers.
- No special configuration is required on the route reflection clients. From a client's perspective, a route reflector is simply a normal IBGP peer. Any BGP version 4 speaker can be a reflector client.
- It is necessary to export routes from the local AS into the local AS when acting as a route reflector.

To accomplish this, routers SSR10 and SSR11 have the following line in their configuration files:

```
ip-router policy redistribute from-proto bgp source-as 64901 to-  
proto bgp target-as 64901
```

- If the cluster ID is changed, all BGP sessions with reflector clients will be dropped and restarted.



# Chapter 7

## Routing Policy Configuration Guide

### Route Import and Export Policy Overview

The SSR family of routers supports extremely flexible routing policies. The SSR allows the network administrator to control import and export of routing information based on criteria including:

- Individual protocol
- Source and destination autonomous system
- Source and destination interface
- Previous hop router
- Autonomous system path
- Tag associated with routes
- Specific destination address

The network administrator can specify a preference level for each combination of routing information being imported by using a flexible masking capability.

The SSR also provides the ability to create advanced and simple routing policies. Simple routing policies provide a quick route redistribution between various routing protocols (RIP and OSPF). Advanced routing policies provide more control over route redistribution.

## Preference

Preference is the value the SSR routing process uses to order preference of routes from one protocol or peer over another. Preference can be set using several different configuration commands. Preference can be set based on one network interface over another, from one protocol over another, or from one remote gateway over another. Preference may not be used to control the selection of routes within an Interior Gateway Protocol (IGP) This is accomplished automatically by the protocol based on metric.

Preference may be used to select routes from the same Exterior Gateway Protocol (EGP) learned from different peers or autonomous systems. Each route has only one preference value associated with it, even though the preference can be set at many places using configuration commands. The last or most specific preference value set for a route is the value used. A preference value is an arbitrarily assigned value used to determine the order of routes to the same destination in a single routing database. The active route is chosen by the lowest preference value.

A default preference is assigned to each source from which the SSR routing process receives routes. Preference values range from 0 to 255 with the lowest number indicating the most preferred route.

The following table summarizes the default preference values for routes learned in various ways. The table lists the CLI commands that set preference, and shows the types of routes to which each CLI command applies. A default preference for each type of route is listed, and the table notes preference precedence between protocols. The narrower the scope of the statement, the higher precedence its preference value is given, but the smaller the set of routes it affects.

**Table 4. Default Preference Values**

Preference	Defined by CLI Command	Default
Direct connected networks	<code>ip-router global set interface</code>	0
OSPF routes	<code>ospf</code>	10
Static routes from config	<code>ip add route</code>	60
RIP routes	<code>rip set preference</code>	100
Point-to-point interface		110
Routes to interfaces that are down	<code>ip-router global set interface down-preference</code>	120
Aggregate/generate routes	<code>aggr-gen</code>	130
OSPF AS external routes	<code>ospf set ase-defaults preference</code>	150
BGP routes	<code>bgp set preference</code>	170

## Import Policies

Import policies control the importation of routes from routing protocols and their installation in the routing databases (Routing Information Base and Forwarding Information Base). Import Policies determine which routes received from other systems are used by the SSR routing process. Every import policy can have up to two components:

- Import-Source
- Route-Filter

### Import-Source

This component specifies the source of the imported routes. It can also specify the preference to be associated with the routes imported from this source.

The routes to be imported can be identified by their associated attributes:

- Type of the source protocol (RIP, OSPF, BGP).
- Source interface or gateway from which the route was received.
- Source autonomous system from which the route was learned.
- AS path associated with a route. Besides autonomous system, BGP also supports importation of routes using AS path regular expressions, and AS path options.
- If multiple communities are specified using the optional-attributes-list, only updates carrying all of the specified communities will be matched. If the specified optional-attributes-list has the value **none** for the **well-known-community** option, then only updates lacking the community attribute will be matched.

In some cases, a combination of the associated attributes can be specified to identify the routes to be imported.

**Note:** It is quite possible for several BGP import policies to match a given update. If more than one policy matches, the first matching policy will be used. All later matching policies will be ignored. For this reason, it is generally desirable to order import policies from most to least specific. An import policy with an optional-attributes-list will match any update with any (or no) communities.

The importation of RIP routes may be controlled by source interface and source gateway. RIP does not support the use of preference to choose between RIP routes. That is left to the protocol metrics.

Due to the nature of OSPF, only the importation of ASE routes may be controlled. OSPF intra-and inter-area routes are always imported into the routing table with a preference of 10. If a tag is specified with the import policy, routes with the specified tag will only be imported.

It is only possible to restrict the importation of OSPF ASE routes when functioning as an AS border router.

Like the other interior protocols, preference cannot be used to choose between OSPF ASE routes. That is done by the OSPF costs.

### Route-Filter

This component specifies the individual routes which are to be imported or restricted. The preference to be associated with these routes can also be explicitly specified using this component.

The preference associated with the imported routes are inherited unless explicitly specified. If there is no preference specified with a route-filter, then the preference is inherited from the one specified with the import-source.

Every protocol (RIP, OSPF, and BGP) has a configurable parameter that specifies default-preference associated with routes imported to that protocol. If a preference is not explicitly specified with the route-filter, as well as the import-source, then it is inherited from the default-preference associated with the protocol for which the routes are being imported.

## Export Policies

Export policies control the redistribution of routes to other systems. They determine which routes are advertised by the Unicast Routing Process to other systems. Every export policy can have up to three components:

- Export-Destination
- Export-Source
- Route-Filter

### Export-Destination

This component specifies the destination where the routes are to be exported. It also specifies the attributes associated with the exported routes. The interface, gateway or the autonomous system to which the routes are to be redistributed are a few examples of export-destinations. The metric, type, tag, and AS-Path are a few examples of attributes associated with the exported routes.

### Export-Source

This component specifies the source of the exported routes. It can also specify the metric to be associated with the routes exported from this source.

The routes to be exported can be identified by their associated attributes:

- Their protocol type (RIP, OSPF, BGP, Static, Direct, Aggregate).
- Interface or the gateway from which the route was received.
- Autonomous system from which the route was learned.
- AS path associated with a route. When BGP is configured, all routes are assigned an AS path when they are added to the routing table. For interior routes, this AS path specifies IGP as the origin and no ASs in the AS path (the current AS is added when the route is exported). For BGP routes, the AS path is stored as learned from BGP.
- Tag associated with a route. Both OSPF and RIP version 2 currently support tags. All other protocols have a tag of zero.

In some cases, a combination of the associated attributes can be specified to identify the routes to be exported.

### Route-Filter

This component specifies the individual routes which are to be exported or restricted. The metric to be associated with these routes can also be explicitly specified using this component.

The metric associated with the exported routes is inherited unless explicitly specified. If there is no metric specified with a route-filter, then the metric is inherited from the one specified with the export-source.

If a metric was not explicitly specified with both the route-filter and the export-source, then it is inherited from the one specified with the export-destination.

Every protocol (RIP, OSPF, and BGP) has a configurable parameter that specifies the default-metric associated with routes exported to that protocol. If a metric is not explicitly specified with the route-filter, export-source as well as export-destination, then it is inherited from the default-metric associated with the protocol to which the routes are being exported.

## Specifying a Route Filter

Routes are filtered by specifying a route-filter that will match a certain set of routes by destination, or by destination and mask. Among other places, route filters are used with import and export policies.

The action taken when no match is found is dependent on the context. For instance, a route that does not match any of the route-filters associated with the specified import or export policies is rejected.

A route will match the most specific filter that applies. Specifying more than one filter with the same destination, mask and modifiers generates an error.

There are three possible formats for a route filter. Not all of these formats are available in all places. In most cases, it is possible to associate additional options with a filter. For example, while creating a martian, it is possible to specify the **allow** option, while creating an import policy, one can specify a **preference**, and while creating an export policy one can specify a **metric**.

The three forms of a route-filter are:

- Network [ exact | refines | between number,number]
- Network/mask [ exact | refines | between number,number]
- Network/masklen [ exact | refines | between number,number]

Matching usually requires both an address and a mask, although the mask is implied in the shorthand forms listed below. These three forms vary in how the mask is specified. In the first form, the mask is implied to be the natural mask of the network. In the second, the mask is explicitly specified. In the third, the mask is specified by the number of contiguous one bits.

If no optional parameters (exact, refines, or between) are specified, any destination that falls in the range given by the network and mask is matched, so the mask of the destination is ignored. If a natural network is specified, the network, any subnets, and any hosts will be matched. Three optional parameters that cause the mask of the destination to also be considered are:

- **Exact:** Specifies that the mask of the destination must match the supplied mask exactly. This is used to match a network, but no subnets or hosts of that network.
- **Refines:** Specifies that the mask of the destination must be more specified (i.e., longer) than the filter mask. This is used to match subnets and/or hosts of a network, but not the network.
- **Between number, number:** Specifies that the mask of the destination must be as or more specific (i.e., as long as or longer) than the lower limit (the first number parameter) and no more specific (i.e., as long as or shorter) than the upper limit (the second number). Note that exact and refines are both special cases of between.

## Aggregates and Generates

Route aggregation is a method of generating a more general route, given the presence of a specific route. It is used, for example, at an autonomous system border to generate a route to a network to be advertised via BGP given the presence of one or more subnets of that network learned via OSPF. The routing process does not perform any aggregation unless explicitly requested.



Route aggregation is also used by regional and national networks to reduce the amount of routing information passed around. With careful allocation of network addresses to clients, regional networks can just announce one route to regional networks instead of hundreds.

Aggregate routes are not actually used for packet forwarding by the originator of the aggregate route, but only by the receiver (if it wishes). Instead of requiring a route-peer to know about individual subnets which would increase the size of its routing table, the peer is only informed about an aggregate-route which contains all the subnets.

Like export policies, aggregate-routes can have up to three components:

- Aggregate-Destination
- Aggregate-Source
- Route-Filter

### **Aggregate-Destination**

This component specifies the aggregate/summarized route. It also specifies the attributes associated with the aggregate route. The preference to be associated with an aggregate route can be specified using this component.

### **Aggregate-Source**

This component specifies the source of the routes contributing to an aggregate/summarized route. It can also specify the preference to be associated with the contributing routes from this source. This preference can be overridden by explicitly specifying a preference with the route-filter.

The routes contributing to an aggregate can be identified by their associated attributes:

- Protocol type (RIP, OSPF, BGP, Static, Direct, Aggregate).
- Autonomous system from which the route was learned.
- AS path associated with a route. When BGP is configured, all routes are assigned an AS path when they are added to the routing table. For interior routes, this AS path specifies IGP as the origin and no ASs in the AS path (the current AS is added when the route is exported). For BGP routes, the AS path is stored as learned from BGP.
- Tag associated with a route. Both OSPF and RIP version 2 currently support tags. All other protocols have a tag of zero.

In some cases, a combination of the associated attributes can be specified to identify the routes contributing to an aggregate.

## Route-Filter

This component specifies the individual routes that are to be aggregated or summarized. The preference to be associated with these routes can also be explicitly specified using this component.

The contributing routes are ordered according to the aggregation preference that applies to them. If there is more than one contributing route with the same aggregating preference, the route's own preferences are used to order the routes. The preference of the aggregate route will be that of contributing route with the lowest aggregate preference.

A route may only contribute to an aggregate route that is more general than itself; it must match the aggregate under its mask. Any given route may only contribute to one aggregate route, which will be the most specific configured, but an aggregate route may contribute to a more general aggregate.

An aggregate-route only comes into existence if at least one of its contributing routes is active.

## Authentication

Authentication guarantees that routing information is only imported from trusted routers. Many protocols like RIP V2 and OSPF provide mechanisms for authenticating protocol exchanges. A variety of authentication schemes can be used. Authentication has two components – an Authentication Method and an Authentication Key. Many protocols allow different authentication methods and keys to be used in different parts of the network.

### Authentication Methods

There are mainly two authentication methods:

**Simple Password:** In this method, an authentication key of up to 8 characters is included in the packet. If this does not match what is expected, the packet is discarded. This method provides little security, as it is possible to learn the authentication key by watching the protocol packets.

**MD5:** This method uses the MD5 algorithm to create a crypto-checksum of the protocol packet and an authentication key of up to 16 characters. The transmitted packet does not contain the authentication key itself, instead it contains a crypto-checksum, called the digest. The receiving router performs a calculation using the correct authentication key and discard the packet if the digest does not match. In addition, a sequence number is maintained to prevent the replay of older packets. This method provides a much stronger assurance that routing data originated from a router with a valid authentication key.

Many protocols allow the specification of two authentication keys per interface. Packets are always sent using the primary keys, but received packets are checked with both the primary and secondary keys before being discarded.

## Authentication Keys and Key Management

An authentication key permits generation and verification of the authentication field in protocol packets. In many situations, the same primary and secondary keys are used on several interfaces of a router. For ease of management of keys, a concept of key-chain is introduced. Each key-chain has an identifier and contains up to two keys. One of keys is the primary key and other is the secondary key. Outgoing packets use the primary authentication key, but incoming packets may match either the primary or secondary authentication key. In the router configuration mode, instead of specifying the key for each interface (which can be up to 16 characters long), a key-chain identifier is specified.

Currently, the SSR supports MD5 specification of OSPF RFC 2178 which uses the MD5 algorithm and an authentication key of up to 16 characters. Thus there are now three authentication schemes available per interface: none, simple and RFC 2178 OSPF MD5 authentication. It is possible to configure different authentication schemes on different interfaces.

RFC 2178 allows multiple MD5 keys per interface. Each key has two times associated with the key:

- a time period that the key will be generated
- a time period that the key will be accepted.

The SSR only allows one MD5 key per interface. Also, there are no options provided to specify the time period during which the key would be generated and accepted - the specified MD5 key is always generated and accepted. Both these limitations would be removed in a future release.

## Configure Simple Routing Policies

Simple routing policies provide an efficient way for routing information to be exchanged between routing protocols. The **redistribute** command can be used to redistribute routes from one routing domain into another routing domain. Redistribution of routes between routing domains is based on route policies. A route policy is a set of conditions based on which routes are redistributed. While the redistribute command is expected to satisfy the export policy requirement for most users, complex export policies may require the use of the commands listed under Export Policies.

The general syntax of the redistribute command is as follows:

```
ip-router policy redistribute from-proto <protocol> to-proto <protocol> [network <ipAddr-mask> [exact | refines | between <low-high>]] [metric <number> | restrict] [source-as <number>] [target-as <number>]
```

The `from-proto` parameter specifies the protocol of the source routes. The values for the `from-proto` parameter are `rip`, `ospf`, `bgp`, `direct`, `static`, `aggregate` and `ospf-ase`. The `to-proto` parameter specifies the destination protocol where the routes are to be exported. The values for the `to-proto` parameter are `rip`, `ospf` and `bgp`. The `network` parameter provides a means to define a filter for the routes to be distributed. The `network` parameter defines a filter that is made up of an IP address and a mask. Routes that match the filter are considered as eligible for redistribution.

Every protocol (RIP, OSPF, and BGP) has a configurable parameter that specifies default-metric associated with routes exported to that protocol. If a metric is not explicitly specified with the `redistribute` command, then it is inherited from the default-metric associated with the protocol to which the routes are being exported.

## Redistributing Static Routes

Static routes may be redistributed to another routing protocol such as RIP or OSPF by the following command. The `network` parameter specifies the set of static routes that will be redistributed by this command. If all static routes are to be redistributed set the `network` parameter to `all`. Note that the `network` parameter is a filter that is used to specify routes that are to be redistributed.

To redistribute static routes, enter one of the following commands in Configure mode:

To redistribute static routes into RIP.	<code>ip-router policy redistribute from-proto static to-proto rip network all</code>
To redistribute static routes into OSPF.	<code>ip-router policy redistribute from-proto static to-proto ospf network all</code>

## Redistributing Directly Attached Networks

Routes to directly attached networks are redistributed to another routing protocol such as RIP or OSPF by the following command. The `network` parameter specifies a set of routes that will be redistributed by this command. If all direct routes are to be redistributed set the `network` parameter to `all`. Note that the `network` parameter is a filter that is used to specify routes that are to be redistributed.

To redistribute direct routes, enter one of the following commands in Configure mode:

To redistribute direct routes into RIP.	<code>ip-router policy redistribute from-proto direct to-proto rip network all</code>
To redistribute direct routes into OSPF.	<code>ip-router policy redistribute from-proto direct to-proto ospf network all</code>

## Redistributing RIP into RIP

The SSR routing process requires RIP redistribution into RIP if a protocol is redistributed into RIP.

To redistribute RIP into RIP, enter the following command in Configure mode:

To redistribute RIP into RIP.	<code>ip-router policy redistribute from-proto rip to-proto rip</code>
-------------------------------	--

## Redistributing RIP into OSPF

RIP routes may be redistributed to OSPF.

To redistribute RIP into OSPF, enter the following command in Configure mode:

To redistribute RIP into OSPF.	<code>ip-router policy redistribute from-proto rip to-proto ospf</code>
--------------------------------	---

## Redistributing OSPF to RIP

For the purposes of route redistribution and import-export policies, OSPF intra- and inter-area routes are referred to as **ospf** routes, and external routes redistributed into OSPF are referred to as **ospf-ase** routes. Examples of **ospf-ase** routes include **static** routes, **rip** routes, **direct** routes, **bgp** routes, or **aggregate** routes, which are redistributed into an OSPF domain.

OSPF routes may be redistributed into RIP. To redistribute OSPF into RIP, enter the following command in Configure mode:

To redistribute ospf-ase routes into rip.	<code>ip-router policy redistribute from-proto ospf-ase to-proto rip</code>
To redistribute ospf routes into rip.	<code>ip-router policy redistribute from-proto ospf to-proto rip</code>

## Redistributing Aggregate Routes

The **aggregate** parameter causes an aggregate route with the specified IP address and subnet mask to be redistributed.

**Note:** The aggregate route must first be created using the **aggr-gen** command. This command creates a specified aggregate route for routes that match the aggregate.

To redistribute aggregate routes, enter one of the following commands in Configure mode:

To redistribute aggregate routes into RIP.	<code>ip-router policy redistribute from-proto aggregate to-proto rip</code>
To redistribute aggregate routes into OSPF.	<code>ip-router policy redistribute from-proto aggregate to-proto OSPF</code>

## Simple Route Redistribution Examples

### Example 1: Redistribution into RIP

For all examples given in this section, refer to the configurations shown in Figure 11 on page 127.

The following configuration commands for router R1:

- Determine the IP address for each interface
- Specify the static routes configured on the router
- Determine its RIP configuration

```

!+++++
! Create the various IP interfaces.
!+++++
interface create ip to-r2 address-netmask 120.190.1.1/16 port et.1.2
interface create ip to-r3 address-netmask 130.1.1.1/16 port et.1.3
interface create ip to-r41 address-netmask 140.1.1.1/24 port et.1.4
interface create ip to-r42 address-netmask 140.1.2.1/24 port et.1.5
interface create ip to-r6 address-netmask 160.1.1.1/16 port et.1.6
interface create ip to-r7 address-netmask 170.1.1.1/16 port et.1.7
!+++++
! Configure a default route through 170.1.1.7
!+++++
ip add route default gateway 170.1.1.7
!+++++
! Configure static routes to the 135.3.0.0 subnets reachable through
! R3.
!+++++
ip add route 135.3.1.0/24 gateway 130.1.1.3
ip add route 135.3.2.0/24 gateway 130.1.1.3
ip add route 135.3.3.0/24 gateway 130.1.1.3
!+++++
! Configure default routes to the other subnets reachable through R2.
!+++++
ip add route 202.1.0.0/16 gateway 120.190.1.2
ip add route 160.1.5.0/24 gateway 120.190.1.2

```

```

!+++++
! RIP Box Level Configuration
!+++++
rip start
rip set default-metric 2
!+++++
! RIP Interface Configuration. Create a RIP interfaces and set
! their type to (version II multicast).
!+++++
rip add interface to-r41
rip add interface to-r42
rip add interface to-r6
rip set interface to-r41 version 2 type multicast
rip set interface to-r42 version 2 type multicast
rip set interface to-r6 version 2 type multicast

```

### Exporting a Given Static Route to All RIP Interfaces

Router R1 has several static routes of which one is the default route. We would export this default route over all RIP interfaces.

```

ip-router policy redistribute from-proto static to-proto rip network
default

```

### Exporting All Static Routes to All RIP Interfaces

Router R1 has several static routes. We would export these routes over all RIP interfaces.

```

ip-router policy redistribute from-proto static to-proto rip network all

```

### Exporting All Static Routes Except the Default Route to All RIP Interfaces

Router R1 has several static routes. We would export all these routes except the default route to all RIP interfaces.

```

ip-router policy redistribute from-proto static to-proto rip network all
ip-router policy redistribute from-proto static to-proto rip network
default restrict

```

## Example 2: Redistribution into OSPF

For all examples given in this section, refer to the configurations shown in Figure 12 on page 131.

The following configuration commands for router R1:

- Determine the IP address for each interface

- Specify the static routes configured on the router
- Determine its OSPF configuration

```

!+++++
! Create the various IP interfaces.
!+++++
interface create ip to-r2 address-netmask 120.190.1.1/16 port
et.1.2
interface create ip to-r3 address-netmask 130.1.1.1/16 port et.1.3
interface create ip to-r41 address-netmask 140.1.1.1/24 port et.1.4
interface create ip to-r42 address-netmask 140.1.2.1/24 port et.1.5
interface create ip to-r6 address-netmask 140.1.3.1/24 port et.1.6
!+++++
! Configure default routes to the other subnets reachable through R2.
!+++++
ip add route 202.1.0.0/16 gateway 120.1.1.2
ip add route 160.1.5.0/24 gateway 120.1.1.2
!+++++
! OSPF Box Level Configuration
!+++++
ospf start
ospf create area 140.1.0.0
ospf create area backbone
ospf set ase-defaults cost 4
!+++++
! OSPF Interface Configuration
!+++++
ospf add interface 140.1.1.1 to-area 140.1.0.0
ospf add interface 140.1.2.1 to-area 140.1.0.0
ospf add interface 140.1.3.1 to-area 140.1.0.0
ospf add interface 130.1.1.1 to-area backbone

```

### Exporting All Interface & Static Routes to OSPF

Router R1 has several static routes. We would like to export all these static routes and direct-routes (routes to connected networks) into OSPF.

```

ip-router policy redistribute from-proto static to-proto ospf
ip-router policy redistribute from-proto direct to-proto ospf

```

**Note:** The network parameter specifying the network-filter is optional. The default value for this parameter is **all**, indicating all networks. Since in the above example, we would like to export all static and direct routes into OSPF, we have not specified this parameter.

### Export all RIP, Interface & Static Routes to OSPF

**Note:** Also export interface, static, RIP, OSPF, and OSPF-ASE routes into RIP.



In the configuration shown in Figure 12 on page 131, suppose if we decide to run RIP Version 2 on network 120.190.0.0/16, connecting routers R1 and R2.

Router R1 would like to export all RIP, interface, and static routes to OSPF.

```
ip-router policy redistribute from-proto rip to-proto ospf
ip-router policy redistribute from-proto direct to-proto ospf
ip-router policy redistribute from-proto static to-proto ospf
```

Router R1 would also like to export interface, static, RIP, OSPF, and OSPF-ASE routes into RIP.

```
ip-router policy redistribute from-proto direct to-proto rip
ip-router policy redistribute from-proto static to-proto rip
ip-router policy redistribute from-proto rip to-proto rip
ip-router policy redistribute from-proto ospf to-proto rip
ip-router policy redistribute from-proto ospf-ase to-proto rip
```

## Configure Advanced Routing Policies

Advanced Routing Policies are used for creating complex import/export policies that cannot be done using the redistribute command. Advanced export policies provide granular control over the targets where the routes are exported, the source of the exported routes, and the individual routes which are exported. It provides the capability to send different routes to the various route-peers. They can be used to provide the same route with different attributes to the various route-peers.

Import policies control the importation of routes from routing protocols and their installation in the routing database (Routing Information Base and Forwarding Information Base). Import policies determine which routes received from other systems are used by the SSR routing process. Using import policies, it is possible to ignore route updates from an unreliable peer and give better preference to routes learned from a trusted peer.

### Export Policies

Advanced export policies can be constructed from one or more of the following building blocks:

- **Export Destinations** - This component specifies the destination where the routes are to be exported. It also specifies the attributes associated with the exported routes. The interface, gateway or the autonomous system to which the routes are to be redistributed are a few examples of export-destinations. The metric, type, tag, and AS-Path are a few examples of attributes associated with the exported routes.
- **Export Sources** - This component specifies the source of the exported routes. It can also specify the metric to be associated with the routes exported from this source. The

routes to be exported can be identified by their associated attributes, such as protocol type, interface or the gateway from which the route was received, and so on.

- Route Filter - This component provides the means to define a filter for the routes to be distributed. Routes that match a filter are considered as eligible for redistribution. This can be done using one of two methods:
  - Creating a route-filter and associating an identifier with it. A route-filter has several network specifications associated with it. Every route is checked against the set of network specifications associated with all route-filters to determine its eligibility for redistribution. The identifier associated with a route-filter is used in the *ip-router policy export* command.
  - Specifying the networks as needed in the **ip-router policy export** command.

If you want to create a complex route-filter, and you intend to use that route-filter in several export policies, then the first method is recommended. If you do not have complex filter requirements, then use the second method.

After you create one or more building blocks, they are tied together by the **iprouter policy export** command.

To create route export policies, enter the following command in Configure mode:

Create an export policy.	<b>ip-router policy export destination</b> <i>&lt;exp-dest-id&gt;</i> <b>[source</b> <i>&lt;exp-src-id&gt;</i> <b>[filter</b> <i>&lt;filter-id&gt;</i> <b>  [network</b> <i>&lt;ipAddr-mask&gt;</i> <b>[exact refines between</b> <i>&lt;low-high&gt;</i> <b>]</b> <b>[metric</b> <i>&lt;number&gt;</i> <b> restrict]]]]</b>
--------------------------	---

The *<exp-dest-id>* is the identifier of the export-destination which determines where the routes are to be exported. If no routes to a particular destination are to be exported, then no additional parameters are required.

The *<exp-src-id>*, if specified, is the identifier of the export-source which determines the source of the exported routes. If a export-policy for a given export-destination has more than one export-source, then the *ip-router policy export destination <exp-dest-id>* command should be repeated for each *<exp-src-id>*.

The *<filter-id>*, if specified, is the identifier of the route-filter associated with this export-policy. If there is more than one route-filter for any export-destination and export-source combination, then the *ip-router policy export destination <exp-dest-id> source <exp-src-id>* command should be repeated for each *<filter-id>*.

## Creating an Export Destination

To create an export destination, enter one the following commands in Configure mode:

Create a RIP export destination.	<code>ip-router policy create rip-export-destination &lt;name&gt;</code>
Create an OSPF export destination.	<code>ip-router policy create ospf-export-destination &lt;name&gt;</code>

## Creating an Export Source

To create an export source, enter one of the following commands in Configure mode:

Create a RIP export source.	<code>ip-router policy create rip-export-source &lt;name&gt;</code>
Create an OSPF export source.	<code>ip-router policy create ospf-export-source &lt;name&gt;</code>

## Import Policies

Import policies can be constructed from one or more of the following building blocks:

- **Import-source** - This component specifies the source of the imported routes. It can also specify the preference to be associated with the routes imported from this source. The routes to be imported can be identified by their associated attributes, including source protocol, Source interface or gateway from which the route was received, and so on.
- **Route Filter** - This component provides the means to define a filter for the routes to be imported. Routes that match a filter are considered as eligible for importation. This can be done using one of two methods:
  - Creating a route-filter and associating an identifier with it. A route-filter has several network specifications associated with it. Every route is checked against the set of network specifications associated with all route-filters to determine its eligibility for importation. The identifier associated with a route-filter is used in the `ip-router policy import` command.
  - Specifying the networks as needed in the `ip-router policy import` command.

If you want to create a complex route-filter, and you intend to use that route-filter in several import policies, then the first method is recommended. If you do not have complex filter requirements, then use the second method.

After you create one or more building blocks, they are tied together by the `iprouter policy import` command.

To create route import policies, enter the following command in Configure mode:

Create an import policy.	<b>ip-router policy import source</b> <i>&lt;imp-src-id&gt;</i> [ <b>filter</b> <i>&lt;filter-id&gt;</i> ] [ <b>network</b> <i>&lt;ipAddr-mask&gt;</i> [ <b>exact refines between</b> <i>&lt;low-high&gt;</i> ] [ <b>preference</b> <i>&lt;number&gt;</i>   <b>restrict</b> ]]
--------------------------	---

The *<imp-src-id>* is the identifier of the import-source that determines the source of the imported routes. If no routes from a particular source are to be imported, then no additional parameters are required.

The *<filter-id>*, if specified, is the identifier of the route-filter associated with this import-policy. If there is more than one route-filter for any import-source, then the *ip-router policy import source <imp-src-id>* command should be repeated for each *<filter-id>*.

## Creating an Import Source

Import sources specify the routing protocol from which the routes are imported. The source may be RIP or OSPF.

To create an import source, enter one of the following commands in Configure mode:

Create a RIP import destination.	<b>ip-router policy create rip-import-source</b> <i>&lt;name&gt;</i>
Create an OSPF import destination.	<b>ip-router policy create ospf-import-source</b> <i>&lt;name&gt;</i>

## Creating a Route Filter

Route policies are defined by specifying a set of filters that will match a certain route by destination, or by destination and mask.

To create route filters, enter the following command in Configure mode:

Create a route filter.	<b>ip-router policy create filter</b> <i>&lt;name-id&gt;</i> <b>network</b> <i>&lt;IP-address/mask&gt;</i>
------------------------	---

## Creating an Aggregate Route

Route aggregation is a method of generating a more general route, given the presence of a specific route. The routing process does not perform any aggregation unless explicitly requested. Aggregate-routes can be constructed from one or more of the following building blocks:

- **Aggregate-Destination** - This component specifies the aggregate/summarized route. It also specifies the attributes associated with the aggregate route. The preference to be associated with an aggregate route can be specified using this component.
- **Aggregate-Source** - This component specifies the source of the routes contributing to an aggregate/summarized route. It can also specify the preference to be associated with the contributing routes from this source. The routes contributing to an aggregate can be identified by their associated attributes, including protocol type, tag associated with a route, and so on.
- **Route Filter** - This component provides the means to define a filter for the routes to be aggregated or summarized. Routes that match a filter are considered as eligible for aggregation. This can be done using one of two methods:
  - Creating a route-filter and associating an identifier with it. A route-filter has several network specifications associated with it. Every route is checked against the set of network specifications associated with all route-filters to determine its eligibility for aggregation. The identifier associated with a route-filter is used in the **ip-router policy aggr-gen** command.
  - Specifying the networks as needed in the *ip-router policy aggr-gen* command.
- If you want to create a complex route-filter, and you intend to use that route-filter in several aggregates, then the first method is recommended. If you do not have complex filter requirements, then use the second method.

After you create one or more building blocks, they are tied together by the *iprouter policy aggr-gen* command.

To create aggregates, enter the following command in Configure mode:

Create an aggregate route.	<b>ip-router policy aggr-gen destination</b> <aggr-dest-id> [source <aggr-src-id> [filter <filter-id> [network <ipAddr-mask> [exact refines between <low-high>] [preference <number> restrict]]]]
----------------------------	--

The <aggr-dest-id> is the identifier of the aggregate-destination that specifies the aggregate/summarized route.

The <aggr-src-id> is the identifier of the aggregate-source that contributes to an aggregate route. If an aggregate has more than one aggregate-source, then the *ip-router policy aggr-gen destination* <aggr-dest-id> command should be repeated for each <aggr-src-id>.

The <filter-id> is the identifier of the route-filter associated with this aggregate. If there is more than one route-filter for any aggregate-destination and aggregate-source combination, then the **ip-router policy aggr-gen destination** <aggr-dest-id> **source** <aggr-src-id> command should be repeated for each <filter-id>.

## Creating an Aggregate Destination

To create an aggregate destination, enter the following command in Configure mode:

Create an aggregate destination.	<code>ip-router policy create aggr-gen-dest &lt;name&gt; network &lt;ipAddr-mask&gt;</code>
----------------------------------	---

## Creating an Aggregate Source

To create an aggregate source, enter the following command in Configure mode:

Create an aggregate source.	<code>ip-router policy create aggr-gen-source &lt;name&gt; protocol &lt;protocol-name&gt;</code>
-----------------------------	--

## Examples of Import Policies

### Example 1: Importing from RIP

The importation of RIP routes may be controlled by any of protocol, source interface, or source gateway. If more than one is specified, they are processed from most general (protocol) to most specific (gateway).

RIP does not support the use of preference to choose between routes of the same protocol. That is left to the protocol metrics.

For all examples in this section, refer to the configuration shown in Figure 11 on page 127.

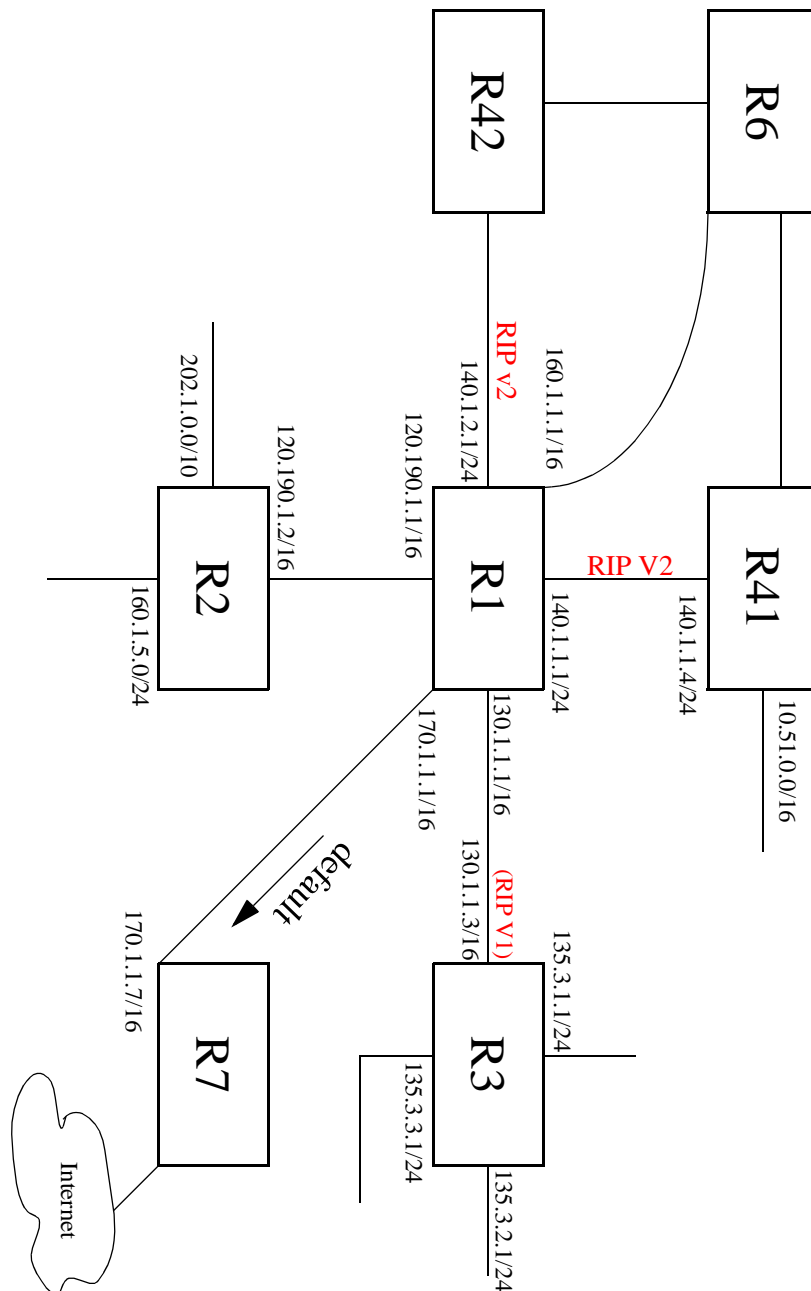

Figure 11. Exporting to RIP

The following configuration commands for router R1

- Determine the IP address for each interface.
- Specify the static routes configured on the router.
- Determine its RIP configuration.

```

!+++++
! Create the various IP interfaces.
!+++++
interface create ip to-r2 address-netmask 120.190.1.1/16 port et.1.2
interface create ip to-r3 address-netmask 130.1.1.1/16 port et.1.3
interface create ip to-r41 address-netmask 140.1.1.1/24 port et.1.4
interface create ip to-r42 address-netmask 140.1.2.1/24 port et.1.5
interface create ip to-r6 address-netmask 160.1.1.1/16 port et.1.6
interface create ip to-r7 address-netmask 170.1.1.1/16 port et.1.7
!+++++
! Configure a default route through 170.1.1.7
!+++++
ip add route default gateway 170.1.1.7
!+++++
! Configure default routes to the 135.3.0.0 subnets reachable through
! R3.
!+++++
ip add route 135.3.1.0/24 gateway 130.1.1.3
ip add route 135.3.2.0/24 gateway 130.1.1.3
ip add route 135.3.3.0/24 gateway 130.1.1.3
!+++++
! Configure default routes to the other subnets reachable through R2.
!+++++
ip add route 202.1.0.0/16 gateway 120.190.1.2
ip add route 160.1.5.0/24 gateway 120.190.1.2
!+++++
! RIP Box Level Configuration
!+++++
rip start
rip set default-metric 2
!+++++
! RIP Interface Configuration. Create a RIP interfaces and set
! their type to (version II multicast).
!+++++
rip add interface to-r41
rip add interface to-r42
rip add interface to-r6
rip set interface to-r41 version 2 type multicast
rip set interface to-r42 version 2 type multicast
rip set interface to-r6 version 2 type multicast

```

### Importing a Selected Subset of Routes from One RIP Trusted Gateway

Router R1 has several RIP peers. Router R41 has an interface on the network 10.51.0.0. By default, router R41 advertises network 10.51.0.0/16 in its RIP updates. Router R1 would like to import all routes except the 10.51.0.0/16 route from its peer R41.



1. Add the peer 140.1.1.41 to the list of trusted and source gateways.

```
rip add source-gateways 140.1.1.41
rip add trusted-gateways 140.1.1.41
```

2. Create a RIP import source with the gateway as 140.1.1.4 since we would like to import all routes except the 10.51.0.0/16 route from this gateway.

```
ip-router policy create rip-import-source ripImpSrc144 gateway
140.1.1.4
```

3. Create the Import-Policy, importing all routes except the 10.51.0.0/16 route from gateway 140.1.1.4

```
ip-router policy import source ripImpSrc144 network all
ip-router policy import source ripImpSrc144 network 10.51.0.0/16
restrict
```

### Importing a Selected Subset of Routes from All RIP Peers Accessible Over a Certain Interface

Router R1 has several RIP peers. Router R41 has an interface on the network 10.51.0.0. By default, router R41 advertises network 10.51.0.0/16 in its RIP updates. Router R1 would like to import all routes except the 10.51.0.0/16 route from all its peer which are accessible over interface 140.1.1.1.

1. Create a RIP import source with the interface as 140.1.1.1, since we would like to import all routes except the 10.51.0.0/16 route from this interface.

```
ip-router policy create rip-import-source ripImpSrc140 interface
140.1.1.1
```

2. Create the Import-Policy importing all routes except the 10.51.0.0/16 route from interface 140.1.1.1

```
ip-router policy import source ripImpSrc140 network all
ip-router policy import source ripImpSrc140 network 10.51.0.0/16
restrict
```

### Example 2: Importing from OSPF

Due to the nature of OSPF, only the importation of ASE routes may be controlled. OSPF intra-and inter-area routes are always imported into the SSR routing table with a preference of 10. If a tag is specified, the import clause will only apply to routes with the specified tag.

It is only possible to restrict the importation of OSPF ASE routes when functioning as an AS border router.

Like the other interior protocols, preference cannot be used to choose between OSPF ASE routes. That is done by the OSPF costs. Routes that are rejected by policy are stored in the table with a negative preference.

For all examples in this section, refer to the configuration shown in [Figure 12 on page 131](#).

Figure 12: Exporting to OSPF

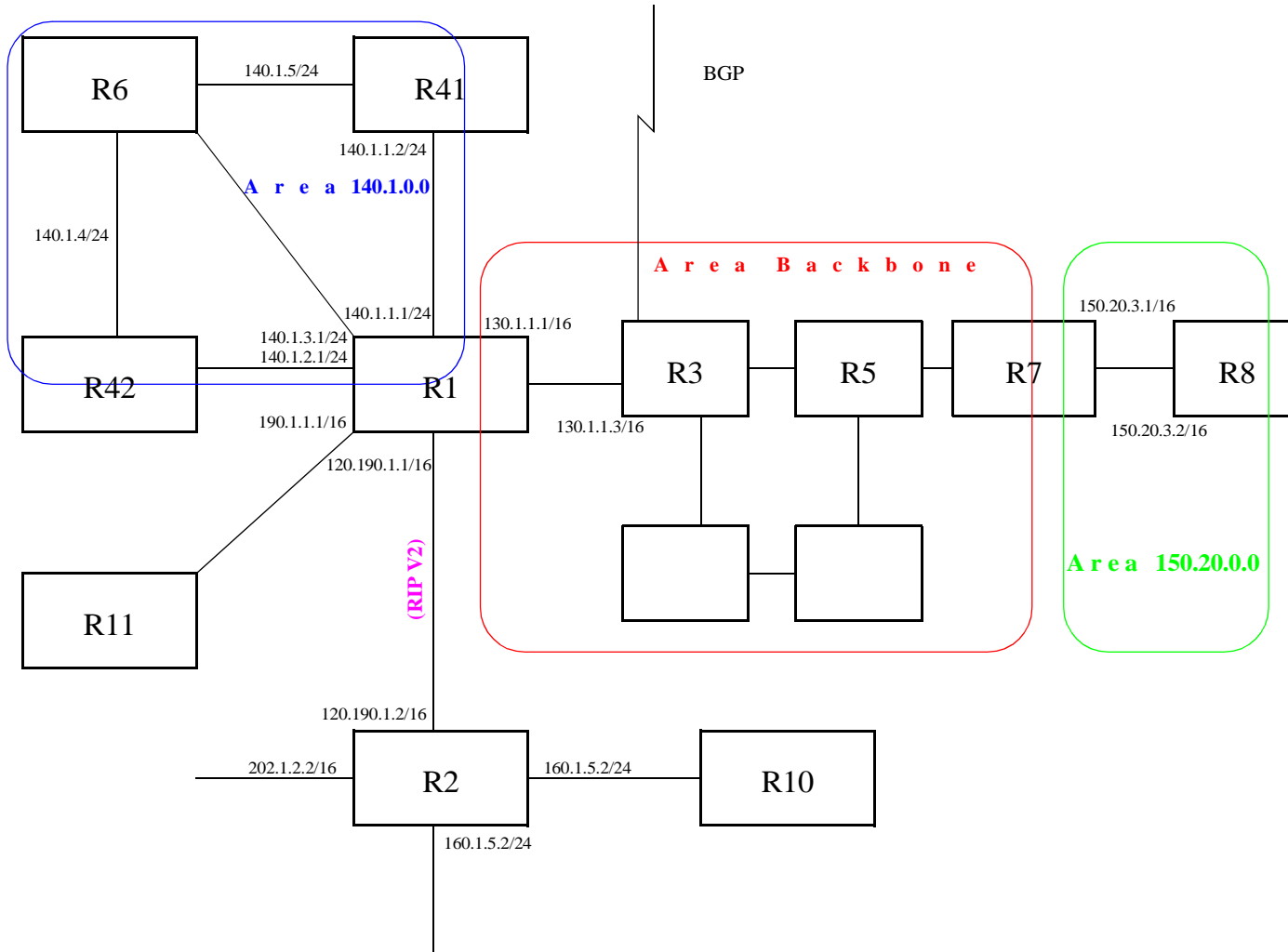

The following configuration commands for router R1:

- Determine the IP address for each interface
- Specify the static routes configured on the router
- Determine its OSPF configuration

```

!+++++
! Create the various IP interfaces.
!+++++
interface create ip to-r2 address-netmask 120.190.1.1/16 port et.1.2
interface create ip to-r3 address-netmask 130.1.1.1/16 port et.1.3
interface create ip to-r41 address-netmask 140.1.1.1/24 port et.1.4
interface create ip to-r42 address-netmask 140.1.2.1/24 port et.1.5
interface create ip to-r6 address-netmask 140.1.3.1/24 port et.1.6
!+++++
! Configure default routes to the other subnets reachable through R2.
!+++++
ip add route 202.1.0.0/16 gateway 120.1.1.2
ip add route 160.1.5.0/24 gateway 120.1.1.2
!+++++
! OSPF Box Level Configuration
!+++++
ospf start
ospf create area 140.1.0.0
ospf create area backbone
ospf set ase-defaults cost 4
!+++++
! OSPF Interface Configuration
!+++++
ospf add interface 140.1.1.1 to-area 140.1.0.0
ospf add interface 140.1.2.1 to-area 140.1.0.0
ospf add interface 140.1.3.1 to-area 140.1.0.0
ospf add interface 130.1.1.1 to-area backbone

```

### Importing a Selected Subset of OSPF-ASE Routes

1. Create a OSPF import source so that only routes that have a tag of 100 are considered for importation.

```
ip-router policy create ospf-import-source ospfImpSrct100 tag 100
```

2. Create the Import-Policy importing all OSPF ASE routes with a tag of 100 except the default ASE route.

```
ip-router policy import source ospfImpSrct100 network all
ip-router policy import source ospfImpSrct100 network default
restrict
```

## Examples of Export Policies

### Example 1: Exporting to RIP

Exporting to RIP is controlled by any of protocol, interface or gateway. If more than one is specified, they are processed from most general (protocol) to most specific (gateway).

It is not possible to set metrics for exporting RIP routes into RIP. Attempts to do this are silently ignored.

If no export policy is specified, RIP and interface routes are exported into RIP. If any policy is specified, the defaults are overridden; it is necessary to explicitly specify everything that should be exported.

RIP version 1 assumes that all subnets of the shared network have the same subnet mask so it is only able to propagate subnets of that network. RIP version 2 removes that restriction, and is capable of propagating all routes when not sending version 1 compatible updates.

To announce routes which specify a next hop of the loopback interface (i.e. static and internally generated default routes) via RIP, it is necessary to specify the metric at some level in the export policy. Just setting a default metric for RIP is not sufficient. This is a safeguard to verify that the announcement is intended.

For all examples in this section, refer to the configuration shown in Figure 11 on page 127.

The following configuration commands for router R1:

- Determine the IP address for each interface
- Specify the static routes configured on the router
- Determine its RIP configuration

```
!+++++
! Create the various IP interfaces.
!+++++
interface create ip to-r2 address-netmask 120.190.1.1/16 port et.1.2
interface create ip to-r3 address-netmask 130.1.1.1/16 port et.1.3
interface create ip to-r41 address-netmask 140.1.1.1/24 port et.1.4
interface create ip to-r42 address-netmask 140.1.2.1/24 port et.1.5
interface create ip to-r6 address-netmask 160.1.1.1/16 port et.1.6
interface create ip to-r7 address-netmask 170.1.1.1/16 port et.1.7
!+++++
! Configure a default route through 170.1.1.7
!+++++
ip add route default gateway 170.1.1.7
!+++++
! Configure default routes to the 135.3.0.0 subnets reachable through
! R3.
```

```

!+++++
ip add route 135.3.1.0/24 gateway 130.1.1.3
ip add route 135.3.2.0/24 gateway 130.1.1.3
ip add route 135.3.3.0/24 gateway 130.1.1.3
!+++++
! Configure default routes to the other subnets reachable through R2.
!+++++
ip add route 202.1.0.0/16 gateway 120.190.1.2
ip add route 160.1.5.0/24 gateway 120.190.1.2
!+++++
! RIP Box Level Configuration
!+++++
rip start
rip set default-metric 2
!+++++
! RIP Interface Configuration. Create a RIP interfaces and set
! their type to (version II multicast).
!+++++
rip add interface to-r41
rip add interface to-r42
rip add interface to-r6
rip set interface to-r41 version 2 type multicast
rip set interface to-r42 version 2 type multicast
rip set interface to-r6 version 2 type multicast

```

### Exporting a Given Static Route to All RIP Interfaces

Router R1 has several static routes, of which one is the default route. We would export this default route over all RIP interfaces.

1. Create a RIP export destination since we would like to export routes into RIP.

```
ip-router policy create rip-export-destination ripExpDst
```

2. Create a Static export source since we would like to export static routes.

```
ip-router policy create static-export-source statExpSrc
```

As mentioned above, if no export policy is specified, RIP and interface routes are exported into RIP. If any policy is specified, the defaults are overridden; it is necessary to explicitly specify everything that should be exported.

Since we would also like to export/redistribute RIP and direct routes into RIP, we would also create export-sources for those protocols.

3. Create a RIP export source since we would like to export RIP routes.

```
ip-router policy create rip-export-source ripExpSrc
```

4. Create a Direct export source since we would like to export direct/interface routes.

```
ip-router policy create direct-export-source directExpSrc
```

5. Create the export-policy redistributing the statically created default route, and all (RIP, Direct) routes into RIP.

```
ip-router policy export destination ripExpDst source statExpSrc
network default
ip-router policy export destination ripExpDst source ripExpSrc
network all
ip-router policy export destination ripExpDst source directExpSrc
network all
```

### Exporting a Given Static Route to a Specific RIP Interface

In this case, router R1 would export/redistribute the default route over its interface 140.1.1.1 only.

1. Create a RIP export destination for interface with address 140.1.1.1, since we intend to change the rip export policy only for interface 140.1.1.1.

```
ip-router policy create rip-export-destination ripExpDst141
interface 140.1.1.1
```

2. Create a static export source since we would like to export static routes.

```
ip-router policy create static-export-source statExpSrc
```

3. Create a RIP export source since we would like to export RIP routes.

```
ip-router policy create rip-export-source ripExpSrc
```

4. Create a Direct export source since we would like to export direct/interface routes.

```
ip-router policy create direct-export-source directExpSrc
```

5. Create the Export-Policy redistributing the statically created default route, and all (RIP, Direct) routes into RIP.

```
ip-router policy export destination ripExpDst141 source statExpSrc
network default
ip-router policy export destination ripExpDst141 source ripExpSrc
network all
ip-router policy export destination ripExpDst141 source directExpSrc
network all
```

### Exporting All Static Routes Reachable Over a Given Interface to a Specific RIP-Interface

In this case, router R1 would export/redistribute all static routes accessible through its interface 130.1.1.1 to its RIP-interface 140.1.1.1 only.

1. Create a RIP export destination for interface with address 140.1.1.1, since we intend to change the rip export policy for interface 140.1.1.1

```
ip-router policy create rip-export-destination ripExpDst141
interface 140.1.1.1
```

2. Create a Static export source since we would like to export static routes.

```
ip-router policy create static-export-source statExpSrc130 interface
130.1.1.1
```

3. Create a RIP export source since we would like to export RIP routes.

```
ip-router policy create rip-export-source ripExpSrc
```

4. Create a Direct export source.

```
ip-router policy create direct-export-source directExpSrc
```

5. Create the Export-Policy, redistributing all static routes reachable over interface 130.1.1.1 and all (RIP, Direct) routes into RIP.

```
ip-router policy export destination ripExpDst141 source
statExpSrc130 network all
ip-router policy export destination ripExpDst141 source ripExpSrc
network all
ip-router policy export destination ripExpDst141 source directExpSrc
network all
```

### Exporting Aggregate-Routes into RIP

In the configuration shown in Figure 11 on page 127, suppose you decide to run RIP Version 1 on network 130.1.0.0/16, connecting routers R1 and R3. Router R1 desires to announce the 140.1.1.0/24 and 140.1.2.0/24 networks to router R3. RIP Version 1 does not carry any information about subnet masks in its packets. Thus it would not be possible to announce the subnets (140.1.1.0/24 and 140.1.2.0/24) into RIP Version 1 without aggregating them.



1. Create an Aggregate-Destination which represents the aggregate/summarized route.

```
ip-router policy create aggr-gen-dest aggrDst140 network
140.1.0.0/16
```

2. Create an Aggregate-Source which qualifies the source of the routes contributing to the aggregate. Since in this case, we do not care about the source of the contributing routes, we would specify the protocol as all.

```
ip-router policy create aggr-gen-source allAggrSrc protocol all
```

3. Create the aggregate/summarized route. This command binds the aggregated route with the contributing routes.

```
ip-router aggr-gen destination aggrDst140 source allAggrSrc network
140.1.1.0/24
ip-router aggr-gen destination aggrDst140 source allAggrSrc network
140.1.2.0/24
```

4. Create a RIP export destination for interface with address 130.1.1.1, since we intend to change the rip export policy only for interface 130.1.1.1.

```
ip-router policy create rip-export-destination ripExpDst130
interface 130.1.1.1
```

5. Create a Aggregate export source since we would to export/redistribute an aggregate/summarized route.

```
ip-router policy create aggr-export-source aggrExpSrc
```

6. Create a RIP export source since we would like to export RIP routes.

```
ip-router policy create rip-export-source ripExpSrc
```

7. Create a Direct export source since we would like to export Direct routes.

```
ip-router policy create direct-export-source directExpSrc
```

8. Create the Export-Policy redistributing all (RIP, Direct) routes and the aggregate route 140.1.0.0/16 into RIP.

```
ip-router policy export destination ripExpDst130 source aggrExpSrc
network 140.1.0.0/16
ip-router policy export destination ripExpDst130 source ripExpSrc
network all
ip-router policy export destination ripExpDst130 source directExpSrc
network all
```

### Example 2: Exporting to OSPF

It is not possible to create OSPF intra- or inter-area routes by exporting routes from the SSR routing table into OSPF. It is only possible to export from the SSR routing table into OSPF ASE routes. It is also not possible to control the propagation of OSPF routes within the OSPF protocol.

There are two types of OSPF ASE routes: type 1 and type 2. The default type is specified by the **ospf set ase-defaults type 1/2** command. This may be overridden by a specification in the **ip-router policy create ospf-export-destination** command.

OSPF ASE routes also have the provision to carry a tag. This is an arbitrary 32-bit number that can be used on OSPF routers to filter routing information. The default tag is specified by the **ospf set ase-defaults tag** command. This may be overridden by a tag specified with the **ip-router policy create ospf-export-destination** command.

Interface routes are not automatically exported into OSPF. They have to be explicitly done.

For all examples in this section, refer to the configuration shown in Figure 12 on page 131.

The following configuration commands for router R1:

- Determine the IP address for each interface
- Specify the static routes configured on the router
- Determine its OSPF configuration

```

!+++++
! Create the various IP interfaces.
!+++++
interface create ip to-r2 address-netmask 120.190.1.1/16 port et.1.2
interface create ip to-r3 address-netmask 130.1.1.1/16 port et.1.3
interface create ip to-r41 address-netmask 140.1.1.1/24 port et.1.4
interface create ip to-r42 address-netmask 140.1.2.1/24 port et.1.5
interface create ip to-r6 address-netmask 140.1.3.1/24 port et.1.6
!+++++
! Configure default routes to the other subnets reachable through R2.
!+++++
ip add route 202.1.0.0/16 gateway 120.1.1.2
ip add route 160.1.5.0/24 gateway 120.1.1.2
!+++++
! OSPF Box Level Configuration
!+++++
ospf start
ospf create area 140.1.0.0
ospf create area backbone
ospf set ase-defaults cost 4
!+++++
! OSPF Interface Configuration
!+++++
ospf add interface 140.1.1.1 to-area 140.1.0.0
ospf add interface 140.1.2.1 to-area 140.1.0.0
ospf add interface 140.1.3.1 to-area 140.1.0.0
ospf add interface 130.1.1.1 to-area backbone

```

### Exporting All Interface & Static Routes to OSPF

Router R1 has several static routes. We would export these static routes as type-2 OSPF routes. The interface routes would be redistributed as type 1 OSPF routes.

1. Create a OSPF export destination for type-1 routes since we would like to redistribute certain routes into OSPF as type 1 OSPF-ASE routes.

```

ip-router policy create ospf-export-destination ospfExpDstType1
type 1 metric 1

```

2. Create a OSPF export destination for type-2 routes since we would like to redistribute certain routes into OSPF as type 2 OSPF-ASE routes.

```

ip-router policy create ospf-export-destination ospfExpDstType2
type 2 metric 4

```

3. Create a Static export source since we would like to export static routes.

```

ip-router policy create static-export-source statExpSrc

```

4. Create a Direct export source since we would like to export interface/direct routes.

```
ip-router policy create direct-export-source directExpSrc
```

5. Create the Export-Policy for redistributing all interface routes and static routes into OSPF.

```
ip-router policy export destination ospfExpDstType1 source
directExpSrc network all
ip-router policy export destination ospfExpDstType2 source
statExpSrc network all
```

### Exporting All RIP, Interface & Static Routes to OSPF

**Note:** Also export interface, static, RIP, OSPF, and OSPF-ASE routes into RIP.

In the configuration shown in Figure 12 on page 131, suppose if we decide to run RIP Version 2 on network 120.190.0.0/16, connecting routers R1 and R2.

We would like to redistribute these RIP routes as OSPF type-2 routes, and associate the tag 100 with them. Router R1 would also like to redistribute its static routes as type 2 OSPF routes. The interface routes would be redistributed as type 1 OSPF routes.

Router R1 would like to redistribute its OSPF, OSPF-ASE, RIP, Static and Interface/Direct routes into RIP.

1. Enable RIP on interface 120.190.1.1/16.

```
rip add interface 120.190.1.1
rip set interface 120.190.1.1 version 2 type multicast
```

2. Create a OSPF export destination for type-1 routes.

```
ip-router policy create ospf-export-destination ospfExpDstType1
type 1 metric 1
```

3. Create a OSPF export destination for type-2 routes.

```
ip-router policy create ospf-export-destination ospfExpDstType2
type 2 metric 4
```

4. Create a OSPF export destination for type-2 routes with a tag of 100.

```
ip-router policy create ospf-export-destination ospfExpDstType2t100
type 2 tag 100 metric 4
```

5. Create a RIP export source.

```
ip-router policy export destination ripExpDst source ripExpSrc
network all
```

6. Create a Static export source.

```
ip-router policy create static-export-source statExpSrc
```

7. Create a Direct export source.

```
ip-router policy create direct-export-source directExpSrc
```

8. Create the Export-Policy for redistributing all interface, RIP and static routes into OSPF.

```
ip-router policy export destination ospfExpDstType1 source
directExpSrc network all
ip-router policy export destination ospfExpDstType2 source
statExpSrc network all
ip-router policy export destination ospfExpDstType2t100 source
ripExpSrc network all
```

9. Create a RIP export destination.

```
ip-router policy create rip-export-destination ripExpDst
```

10. Create OSPF export source.

```
ip-router policy create ospf-export-source ospfExpSrc type OSPF
```

11. Create OSPF-ASE export source.

```
ip-router policy create ospf-export-source ospfAseExpSrc
type OSPF-ASE
```

12. Create the Export-Policy for redistributing all interface, RIP, static, OSPF and OSPF-ASE routes into RIP.

```
ip-router policy export destination ripExpDst source statExpSrc
network all
ip-router policy export destination ripExpDst source ripExpSrc
network all
ip-router policy export destination ripExpDst source directExpSrc
network all
ip-router policy export destination ripExpDst source ospfExpSrc
network all
ip-router policy export destination ripExpDst source ospfAseExpSrc
network all
```

# Chapter 8

# Multicast Routing Configuration Guide

## IP Multicast Overview

Multicast routing on the SSR is supported through DVMRP and IGMP. IGMP is used to determine host membership on directly attached subnets. DVMRP is used to determine forwarding of multicast traffic between SSRs.

This chapter:

- Provides an overview of the SSR's implementation of the Internet Group Management Protocol (IGMP)
- Provides an overview of the SSR's implementation of the Distance Vector Multicast Routing Protocol (DVMRP)
- Discusses configuring DVMRP routing on the SSR
- Discusses configuring IGMP on the SSR.

## IGMP Overview

The SSR supports IGMP Version 2.0 as defined in RFC 2236. IGMP is run on a per-IP interface basis. An IP interface can be configured to run just IGMP and not DVMRP. Since multiple physical ports (VLANs) can be configured with the same IP interface on the SSR, IGMP keeps track of multicast host members on a per-port basis. Ports belonging to an IP VLAN without any IGMP membership will not be forwarded any multicast traffic.

The SSR allows per-interface control of the host query interval and response time. Query interval defines the time between IGMP queries. Response time defines the time the SSR will wait for host responses to IGMP queries. The SSR can be configured to deny or accept group membership filters.

## DVMRP Overview

DVMRP is an IP multicast routing protocol. On the SSR, DVMRP routing is implemented as specified in the **draft-ietf-idmr-dvmrp-v3-06.txt** file, which is an Internet Engineering Task Force (IETF) document. The SSR's implementation of DVMRP supports the following:

- mtrace, which is a utility that tracks the multicast path from a source to a receiver.
- Generation identifiers, which are assigned to DVMRP whenever that protocol is started on a router.
- Pruning, which is an operation DVMRP routers perform to exclude interfaces not in the shortest path tree.

DVMRP uses the Reverse Path Multicasting (RPM) algorithm to perform pruning. In RPM, a source network rather than a host is paired with a multicast group. This is known as an (S,G) pair. RPM permits the SSR to maintain multiple (S,G) pairs.

On the SSR, DVMRP can be configured on a per-interface basis. An interface does not have to run both DVMRP and IGMP. You can start and stop DVMRP independently from other multicast routing protocols. IGMP starts and stops automatically with DVMRP. The SSR supports up to 64 multicast interfaces.

To support backward compatibility on DVMRP interfaces, you can configure the router expire time and prune time on each SSR DVMRP interface. This lets it work with older versions of DVMRP.

You can use threshold values and scopes to control internetwork traffic on each DVMRP interface. Threshold values determine whether traffic is either restricted or not restricted to a subnet, site, or region. Scopes define a set of multicast addresses of devices to which the SSR can send DVMRP data. Scopes can include only addresses of devices on a company's internal network and cannot include addresses that require the SSR to send DVMRP data on the Internet. The SSR also allows control of routing information exchange with peers through route filter rules.

You can also configure tunnels on SSR DVMRP interfaces. A tunnel is used to send packets between routers separated by gateways that do not support multicast routing. A tunnel acts as a virtual network between two routers running DVMRP. A tunnel does not run IGMP. The SSR supports a maximum of eight tunnels.

**Note:** Tunnel traffic is not optimized on a per-port basis, and it goes to all ports on an interface, even though IGMP keeps per-port membership information. This is done to minimize CPU overload for tunneled traffic.



## Configure IGMP

You configure IGMP on the SSR by performing the following configuration tasks.

- Creating IP interfaces
- Setting global parameters that will be used for all the interfaces on which DVMRP is enabled
- Configuring IGMP on individual interfaces. You do so by enabling and disabling IGMP on interfaces and then setting IGMP parameters on the interfaces on which IGMP is enabled
- Start the multicast routing protocol (i.e., DVMRP)

### Configuring IGMP on an IP Interface

By default IGMP is disabled on the SSR.

To enable IGMP on an interface, enter the following command in Configure mode:

Enable IGMP on an interface.	<code>igmp enable interface &lt;ipAddr&gt;</code>
------------------------------	---

### Configure IGMP Query Interval

You can configure the SSR with a different IGMP Host Membership Query time interval. The interval you set applies to all ports on the SSR. The default query time interval is 125 seconds.

To configure the IGMP host membership query time interval, enter the following command in Configure mode:

Configure the IGMP host membership query time interval.	<code>igmp set queryinterval &lt;num&gt;</code>
---	---

### Configure IGMP Response Wait Time

You can configure the SSR with a wait time for IGMP Host Membership responses which is different from the default. The wait time you set then applies to all ports on the SSR. The default response time is 10 seconds.

To configure the host response wait time, enter the following command in Configure mode:

Configure the IGMP host response wait time.	<code>igmp set responsetime &lt;num&gt;</code>
---	--

## Configure Per-Interface Control of IGMP Membership

You can configure the SSR to control IGMP membership on a per-interface basis. An interface can be configured to be allowed or not allowed membership to a particular group.

To configure the per-interface membership control, enter the following commands in Configure mode:

Allow a host group membership to a specific group.	<code>igmp set interface &lt;ip-addr&gt; allowed-groups &lt;ip-addr/subnet mask&gt;</code>
Disallow a host group membership to a specific group.	<code>igmp set interface &lt;ip-addr&gt; not-allowed-groups &lt;ip-addr/subnet mask&gt;</code>

## Configure DVMRP

You configure DVMRP routing on the SSR by performing the following DVMRP-configuration tasks.

- Creating IP interfaces.
- Setting global parameters that will be used for all the interfaces on which DVMRP is enabled.
- Configuring DVMRP on individual interfaces. You do so by enabling and disabling DVMRP on interfaces and then setting DVMRP parameters on the interfaces on which DVMRP is disabled.
- Defining DVMRP tunnels, which IP uses to send multicast traffic between two end points.

## Starting and Stopping DVMRP

DVMRP is disabled by default on the SSR.

To start or stop DVMRP, enter one of the following commands in Configure mode:

Start DVMRP.	<b>dvmrp start</b>
Stop DVMRP.	<b>no dvmrp start</b>

## Configure DVMRP on an Interface

DVMRP can be controlled/configured on per-interface basis. An interface does not have to run both DVMRP and IGMP together. DVMRP can be started or stopped IGMP starts and stops automatically with DVMRP.

To enable IGMP on an interface, enter the following command in the Configure mode:

Enable DVMRP on an interface.	<b>dvmrp enable interface</b> <ipAddr>   <interface-name>
-------------------------------	---

## Configure DVMRP Parameters

In order to support backward compatibility, DVMRP neighbor timeout and prune time can be configured on a per-interface basis. The default neighbor timeout is 35 seconds. The default prune time is 7200 seconds (2 hours).

To configure neighbor timeout or prune time, enter one of the following commands in Configure mode:

Configure the DVMRP neighbor timeout.	<b>dvmrp set interface</b> <ip-addr> <b>neighbor-timeout</b> <number>
Configure the DVMRP prune time.	<b>dvmrp set interface</b> <ip-addr> <b>prunetime</b> <number>

## Configure the DVMRP Routing Metric

You can configure the DVMRP routing metric associated with a set of destinations for DVMRP reports. The default metric is 1.

To configure the DVMRP routing metric, enter the following command in Configure mode:

Configure the DVMRP routing metric.	<b>dvmrp set interface</b> <ip-addr> <b>metric</b> <number>
-------------------------------------	---

## Configure DVMRP TTL & Scope

For control over internet traffic, per-interface control is allowed through Scopes and TTL thresholds.

The TTL value controls whether packets are forwarded from an interface. Conventional guidelines for assigning TTL values to a multicast application, and their corresponding SSR setting for DVMRP threshold:

TTL = 1      Threshold = 1      Application restricted to subnet

TTL < 16    Threshold = 16      Application restricted to a site

TTL < 64    Threshold = 64      Application restricted to a region

TTL < 128   Threshold = 128    Application restricted to a continent

TTL = 255                      Application not restricted

To configure the TTL Threshold, enter the following command in Configure mode:

Configure the TTL Threshold.	<b>dvmrp set interface</b> <i>&lt;ip-addr&gt;</i> <b>threshold</b> <i>&lt;number&gt;</i>
------------------------------	---

TTL thresholding is not always considered useful. There is another approach of a range of multicast addresses for “administrative” scoping. In other words, such addresses would be usable within a certain administrative scope, a corporate network, for instance, but would not be forwarded across the internet. The range from 239.0.0.0 through 239.255.255.255 is being reserved for administratively scoped applications. Any organization can currently assign this range of addresses and the packets will not be sent out of the organization. In addition, multiple scopes can be defined on per-interface basis.

To prevent the SSR from forwarding any data destined to a scoped group on an interface, enter the following command in the Configure mode:

Configure the DVMRP scope.	<b>dvmrp set interface</b> <i>&lt;ip-addr&gt;</i> <b>scope</b> <i>&lt;ip-addr/mask&gt;</i>
----------------------------	---

## Configure a DVMRP Tunnel

The SSR supports DVMRP tunnels to the MBONE (the multicast backbone of the Internet). You can configure a DVMRP tunnel on a router if the other end is running DVMRP. The SSR then sends and receives multicast packets over the tunnel. Tunnels are CPU-intensive; they are not switched directly through the SSR’s multitasking ASICs.

DVMRP tunnels need to be created before being enabled. Tunnels are recognized by the tunnel name. Once a DVMRP tunnel is created, you can enable DVMRP on the interface. The SSR supports a maximum of eight tunnels.

To configure a DVMRP tunnel, enter the following command in Configure mode:

Configure a DVMRP tunnel to MBONE.	<b>dvmrp create tunnel</b> <i>&lt;string&gt;</i> <b>local</b> <i>&lt;ip-addr&gt;</i> <b>remote</b> <i>&lt;ip-addr&gt;</i>
------------------------------------	---

You can also control the rate of DVMRP traffic in a DVMRP tunnel. The default rate is 500 Kbps.

To control the rate of DVMRP traffic, enter the following command in Configure mode:

Configure the rate in a DVMRP tunnel.	<b>dvmrp set interface</b> <i>&lt;ip-addr&gt;</i> <b>rate</b> <i>&lt;number&gt;</i>
---------------------------------------	---

## Monitor IGMP & DVMRP

You can monitor IGMP and DVMRP information on the SSR.

To display IGMP and DVMRP information, enter the following commands in the Enable mode.

Show all interfaces running DVMRP. Also shows the neighbors on each interface.	<b>dvmrp show interface</b>
Display DVMRP routing table.	<b>dvmrp show routes</b>
Shows all the interfaces and membership details running IGMP.	<b>igmp show interface</b>
Shows all IGMP group memberships on a port basis.	<b>igmp show memberships</b>
Show all IGMP timers.	<b>igmp show timers</b>
Show information about multicasts registered by IGMP.	<b>12-tables show igmp-mcast-registration</b>
Show IGMP status on a VLAN.	<b>12-tables show vlan-igmp-status</b>
Show all multicast Source, Group entries.	<b>multicast show cache</b>

Show all interfaces running multicast protocols (IGMP, DVMRP).	<b>multicast show interfaces</b>
Show all multicast routes.	<b>multicast show mroutes</b>

## Configuration Examples

The following is a sample SSR configuration for DVMRP and IGMP. Seven subnets are created. IGMP is enabled on 4 IP interfaces. The IGMP query interval is set to 30 seconds. DVMRP is enabled on 5 IP interfaces. IGMP is not running on “downstream” interfaces.

```

! Create VLANS.
!
vlan create upstream ip
vlan add ports et.5.3 et.5.4 to upstream
!
! Create IP interfaces
!
interface create ip mls15 address-netmask 172.1.1.10/24 port et.5.8
interface create ip company address-netmask 207.135.89.64/25 port et.5.1
interface create ip test address-netmask 10.135.89.10/25 port et.1.8
interface create ip rip address-netmask 190.1.0.1 port et.1.4
interface create ip mbone address-netmask 207.135.122.11/29 port et.1.1
interface create ip downstream address-netmask 10.40.1.10/24 vlan upstream
!
! Enable IGMP interfaces.
!
igmp enable interface 10.135.89.10
igmp enable interface 172.1.1.10
igmp enable interface 207.135.122.11
igmp enable interface 207.135.89.64
!
! Set IGMP Query Interval
!
igmp set queryinterval 30
!
! Enable DVMRP
!
dvmrp enable interface 10.135.89.10
dvmrp enable interface 172.1.1.10
dvmrp enable interface 207.135.122.11
dvmrp enable interface 207.135.89.64
dvmrp enable interface 10.40.1.10
!
! Set DVMRP parameters
!
dvmrp set interface 172.1.1.10 neighbor-timeout 200
!
! Start DVMRP
!
dvmrp start

```

# Chapter 9

## IPX Routing Configuration Guide

### IPX Routing Overview

The Internetwork Packet Exchange (IPX) is a datagram connectionless protocol for the Novell NetWare environment. You can configure the SSR for IPX routing and SAP. Routers interconnect different network segments and by definition are network layer devices. Thus routers receive their instructions for forwarding a packet from one segment to another from a network layer protocol. IPX, with the help of RIP and SAP, perform these Network Layer Task. These tasks include addressing, routing, and switching information packets from one location to another on the internetwork.

IPX defines internetwork and intranode addressing schemes. IPX internetwork addressing is based on network numbers assigned to each network segment on a Novell NetWare internetwork. The IPX intranode address comes in the form of socket numbers. Because several processes are normally operating within a node, socket numbers provide a way for each process to distinguish itself.

The IPX packet consists of two parts: a 30-byte header and a data portion. The network node and socket addresses for both the destination and source are held within the IPX header.

### RIP (Routing Information Protocol)

IPX routers use RIP to create and dynamically maintain a database of internetwork routing information. RIP allows a router to exchange routing information with a neighboring router. As a router becomes aware of any change in the internetwork layout,

this information is immediately broadcast to any neighboring routers. Routers also send periodic RIP broadcast packets containing all routing information known to the router.

The SSR uses IPX RIP to create and maintain a database of internetwork routing information. The SSR's implementation of RIP allows the following exchanges of information:

- Workstations locate the fastest route to a network number by broadcasting a route request.
- Routers request routing information from other routers to update their own internal tables by broadcasting a route request.
- Routers respond to route requests from workstations and other routers.
- Routers perform periodic broadcasts to make sure that all other routers are aware of the internetwork configuration.
- Routers perform broadcasting whenever they detect a change in the internetwork configurations.

SSR's RIP implementation follows the guidelines given in Novell's *IPX RIP and SAP Router Specification Version 1.30* document.

## SAP (Service Advertising Protocol)

SAP provides routers with a means of exchanging internetwork service information. Though SAP, servers advertise their services and addresses. Routers gather this information and share it with other routers. This allows routers to create and dynamically maintain a database of internetwork service information. SAP allows a router to exchange information with a neighboring SAP agent. As a router becomes aware of any change in the internetwork server layout, this information is immediately broadcast to any neighboring SAP agents. SAP broadcast packets containing all server information known to the router are also sent periodically.

The SSR uses IPX SAP to create and maintain a database of internetwork service information. The SSR's implementation of SAP allows the following exchanges of information:

- Workstations locate the name and address of the nearest server of certain type
- Router's request for the names and addresses of either all or certain type of servers
- Response to workstation or router's request
- Periodic broadcast to make sure all other routers are aware of the internetwork configuration
- Perform broadcasting whenever they detect a change in the internetwork configurations



## Configuring IPX RIP & SAP

This section provides an overview of configuring various IPX parameters and setting up IPX interfaces.

### IPX RIP

On the SSR, RIP automatically runs on all IPX interfaces. The SSR will keep multiple routes to the same network having the lowest ticks and hop count. Static routes can be configured on the SSR using the CLI's **ipx add route** command. Through the use of RIP filters, the SSR can control the acceptance and advertisement of networks per-interface.

### IPX SAP

On the SSR, SAP automatically runs on all the IPX interfaces. The SSR will keep multiple SAP's having the lowest hop count. Static SAPs can be configured on the SSR using the CLI's **ipx add sap** command. Through the use of SAP filters, the SSR can control the acceptance and advertisements of services per-interface.

## Creating IPX Interfaces

When you create IPX interfaces on the SSR, you provide information about the interface (such as its name, output MAC encapsulation, and IPX address). You also enable or disable the interface and bind the interface to a single port or VLAN.

**Note:** Interfaces bound to a single port go down when the port goes down but interfaces bound to a VLAN remain up as long as at least one port in that VLAN remains active.

The procedure for creating an IPX interface depends on whether you are binding that interface to a single port or a VLAN. Separate discussions on the different procedures follow.

## IPX Addresses

The IPX address is a 12-byte number divided into three parts. The first part is the 4-byte (8-character) IPX external network number. The second part is the 6-byte (12-character) node number. The third part is the 2-byte (4-character) socket number.

## Configuring IPX Interfaces and Parameters

This section provides an overview of configuring various IPX parameters and setting up IPX interfaces.

### Configure IPX Addresses to Ports

You can configure one IPX interface directly to a physical port.

To configure an IPX interface to a port, enter one of the following commands in Configure mode:

Configure an IPX interface to a physical port.	<b>interface create ipx</b> <i>&lt;InterfaceName&gt;</i> <b>address-mask</b> <i>&lt;ipxAddr-mask&gt;</i> <b>port</b> <i>&lt;port&gt;</i>
--	--

### Configure IPX Interfaces for a VLAN

You can configure one IPX interface per VLAN.

To configure a VLAN with an IPX interface, enter the following command in Configure mode:

Create an IPX interface for a VLAN.	<b>interface create ipx</b> <i>&lt;InterfaceName&gt;</i> <b>address-mask</b> <i>&lt;ipxAddr-mask&gt;</i> <b>vlan</b> <i>&lt;name&gt;</i>
-------------------------------------	--

### Specify IPX Encapsulation Method

The SmartSwitch Router supports two encapsulation types for IPX. You can configure encapsulation type on a per-interface basis.

- Ethernet II The standard ARPA Ethernet Version 2.0 encapsulation, which uses a 16-bit protocol type code (the default encapsulation method)
- 802.3 SNAP: SNAP IEEE 802.3 encapsulation, in which the type code becomes the frame length for the IEEE 802.2 LLC encapsulation (destination and source Service Access Points, and a control byte)
- 802.3: 802.3 encapsulation method used within Novell IPX environments

- 802.2: 802.2 encapsulation method used within Novell IPX environments

Configure Ethernet II encapsulation.	<b>interface create ipx</b> <Interface Name> <b>output-mac-encapsulation ethernet_II</b>
Configure 802.3 SNAP encapsulation.	<b>interface create ipx</b> <Interface Name> <b>output-mac-encapsulation ethernet_snap</b>
Configure 802.3 IPX encapsulation.	<b>interface create ipx</b> <Interface Name> <b>output-mac-encapsulation ethernet_802.3</b>
Configure 802.2 IPX encapsulation.	<b>interface create ipx</b> <Interface Name> <b>output-mac-encapsulation ethernet_802.2_ipx</b>

## Configure IPX Routing

By default, IPX routing is enabled on the SSR.

### Enable IPX RIP

IPX RIP is enabled by default on the SSR. You must first create an IPX interface or assign an IPX interface to a VLAN before RIP will start learning routes.

### Enable SAP

IPX SAP is enabled by default on the SSR. You must first create an IPX interface or assign an IPX interface to a VLAN before SAP will start learning services.

## Configure Static Routes

In a Novell NetWare network, the SSR uses RIP to determine the best paths for routing IPX. However, you can add static RIP routes to RIP routing table to explicitly specify a route.

To add a static RIP route, enter the following command in Configure mode:

Add a static RIP route.	<b>ipx add route</b> <networkaddr> <nextrouter or network node> <metric> <ticks>
-------------------------	---

## Configure Static SAP Table Entries

Servers in an IPX network use SAP to advertise services via broadcast packets. Services from servers are stored in the Server Information Table. If you want to have a service explicitly advertised with different hops then you will need to configure a static entry.

To add an entry into the Server Information Table, enter the following command in Configure mode:

Add a SAP table entry.	<b>ipx add sap</b> <service type> <SrcName> <node> <socket> <metric> <interface-network>
------------------------	---

## Control Access to IPX Networks

To control access to IPX networks, you create access control lists and then apply them with filters to individual interfaces. The SSR supports the following IPX access lists that you can use to filter various kinds of traffic:

- IPX access control list: Restrict traffic based on the source address, destination address, source socket, destination socket, source network mask or destination network mask.
- SAP access control list: Restricts advertisements or learning of SAP services. These lists are used for SAP filters. They can also be used for Get Nearest Server (GNS) replies.
- RIP access control list: Restricts advertisements or learning of networks.

### Create an IPX Access Control List

IPX access control lists control which IPX traffic is received from or sent to an interface based on source address, destination address, source socket, destination socket, source network mask or destination network mask. This is used to permit or deny traffic from one IPX end node to another.

To create an IPX access control list, perform the following task in the Configure mode:

Create an IPX access control list.	<b>acl</b> <name> <b>permit   deny ipx</b> <SrcNetwork Node> <DstNetworkNode> <SrcSocket> <SrcNetMask> <DstSocket> <DstNetMask>
------------------------------------	--

Once an IPX access control list has been created, you must apply the access control list to an IPX interface. To apply an IPX access control list, enter the following command in Configure mode:

Apply an IPX access control list.	<b>acl</b> <name> <b>apply interface</b> <Interface Name> <b>input   output</b> [ <b>logging</b> <b>[on   off]</b> ]
-----------------------------------	---

### Create an IPX Type 20 Access Control List

IPX type 20 access control lists control the forwarding of IPX type 20 packets. To create an IPX type 20 access control list, enter the following command in Configure mode:

Create an IPX type 20 access control list.	<b>acl</b> <name> <b>permit deny ipxtype20</b>
--	--

### Create an IPX SAP Access Control List

IPX SAP access control lists control which SAP services are available on a server. To create an IPX SAP access control list, enter the following command in Configure mode:

Create an IPX SAP access control list.	<b>acl</b> <name> <b>permit deny ipxsap</b> <ServerNetworkNode> <ServiceType> <ServiceName>
--	---

Once an IPX SAP access control list has been created, you must apply the access control list to an IPX interface. To apply an IPX SAP access control list, enter the following command in Configure mode:

Apply an IPX SAP access control list.	<b>acl</b> <name> <b>apply interface</b> <InterfaceName> <b>input output</b> <b>[logging [on off]]</b>
---------------------------------------	--

### Create an IPX GNS Access Control List

IPX GNS access control lists control which SAP services the SSR can reply with to a get nearest server (GNS) request. To create an IPX GNS access control list, enter the following command in Configure mode:

Create an IPX GNS access control list.	<b>acl</b> <name> <b>permit deny ipxgns</b> <ServerNetworkNode> <ServiceType> <ServiceName>
--	---

Once an IPX GNS access control list has been created, you must apply the access control list to an IPX interface. To apply an IPX GNS access control list, enter the following command in Configure mode:

Apply an IPX GNS access control list.	<b>acl</b> <name> <b>apply interface</b> <InterfaceName> <b>output</b> <b>[logging [on off]]</b>
---------------------------------------	--

### Create an IPX RIP Access Control List

IPX RIP access control lists control which RIP updates are allowed. To create an IPX RIP access control list, perform the following task in the Configure mode:

Create an IPX RIP access control list.	<b>acl</b> <name> <b>permit deny ipxrip</b> <FromNetwork> <ToNetwork>
--	--

Once an IPX RIP access control list has been created, you must apply the access control list to an IPX interface. To apply an IPX RIP access control list, enter the following command in Configure mode:

Apply an IPX RIP access control list.	<b>acl</b> <name> <b>apply interface</b> <Interface Name> <b>input output</b> <b>[logging [on off]]</b>
---------------------------------------	---

## Monitor an IPX Network

The SSR reports IPX interface information and RIP or SAP routing information.

To display IPX information, enter the following command in Enable mode:

Show a RIP entry in the IPX RIP table.	<b>ipx find rip</b> <DstNetwork>
Show a SAP entry in the IPX SAP table.	<b>ipx find sap</b> <type> <ServiceType> <ServiceName> <ServerNetwork>
Show IPX interface information.	<b>ipx show interfaces</b> <interface-name>
Show IPX RIP table.	<b>ipx show tables rip</b>
Show IPX routing table.	<b>ipx show tables routing</b>
Show IPX SAP table.	<b>ipx show tables sap</b>
Show IPX RIP/SAP table summary	<b>ipx show tables summary</b>

## Configuration Examples

This example performs the following configuration:

- Creates IPX interfaces
- Adds static RIP routes
- Adds static SAP entries7.pdf.zip
- Adds a RIP access list

- Adds a SAP access list
- Adds a GNS access list

```
! Create interface ipx1 with ipx address AAAAAAAA
interface create ipx ipx1 address AAAAAAAA port et.1.1 output-mac-
encapsulation ethernet_802.2_IPX
!
! Create interface ipx2 with ipx addressBBBBBBBB
interface create ipx ipx2 addressBBBBBBBB port et.1.2 output-mac-
encapsulation ethernet_802.3
!
!Add static route to network 9
ipx add route 9BBBBBBBB.01:02:03:04:05:06 1 1
!
!Add static sap
ipx add sap 0004 FILESERVER1 9.03:04:05:06:07:08 452 1 AAAAAAAA
!
!RIP Access List
acl 100 deny ipxrip 1 2
!
!RIP inbound filter
acl 100 apply interface ipx1 input
!
!SAP Access List
acl 200 deny ipxsap A.01:03:05:07:02:03 0004 FILESERVER2
!
!SAP outbound filter to interface ipx2
acl 200 apply interface ipx2 output
!
!IPX type 20 access list
acl 300 deny ipxtype20
!
!IPX type 20 inbound filter to interface ipx2
acl 300 apply interface ipx2 input
!
!GNS Access List
acl 300 deny ipxgns A.01:03:05:07:02:03 0004 FILESERVER2
acl 200 apply interface ipx2 output
```





# Chapter 10

## Security Configuration Guide

### Security Overview

The SSR provides security features that help control access to the SSR and filter traffic going through the SSR. Access to the SSR can be controlled by:

- Enabling RADIUS
- Enabling TACACS
- Enabling TACACS Plus
- Login authentication

Traffic filtering on the SSR enables:

- Layer-2 security filters - Perform filtering on source or destination MAC addresses.
- Layer3/4 Access Control Lists - Perform filtering on source or destination IP address, source or destination TCP/UDP port, TOS or protocol type for IP traffic. Perform filtering on source or destination IPX address, or source or destination IPX socket. Perform access control to services provided on the SSR, for example, Telnet server and HTTP server.

**Note:** Currently, Source Filtering is available on Cabletron Systems WAN cards, however application must take place on the entire WAN card.

## Configuring SSR Access Security

### Configure RADIUS

You can secure login or Enable mode access to the SSR by enabling a Remote Authentication Dial-In Service (RADIUS) client. A RADIUS server responds to the SSR RADIUS client to provide authentication.

You can configure up to five RADIUS server targets on the SSR. A timeout is set to tell the SSR how long to wait for a response from RADIUS servers.

To configure RADIUS security, enter the following commands in Configure mode:

Specify a RADIUS server.	<b>radius set host</b> <hostname or IP-addr>
Set the RADIUS time to wait for a RADIUS server reply.	<b>radius set timeout</b> <number>
Determine the SSR action if no server responds.	<b>radius set last-resort password succeed</b>
Enable RADIUS.	<b>radius enable</b>

### Monitor RADIUS

You can monitor RADIUS configuration and statistics within the SSR.

To monitor RADIUS, enter the following commands in Enable mode:

Show RADIUS server statistics.	<b>radius show stats</b>
Show all RADIUS parameters.	<b>radius show all</b>

### Configure TACACS

In addition, Enable mode access to the SSR can be made secure by enabling a Terminal Access Controller Access Control System (TACACS) client. Without TACACS, TACACS Plus, or RADIUS enabled, only local password authentication is performed on the SSR. The TACACS client provides user name and password authentication for Enable mode. A TACACS server responds to the SSR TACACS client to provide authentication.

You can configure up to five TACACS server targets on the SSR. A timeout is set to tell the SSR how long to wait for a response from TACACS servers.

To configure TACACS security, enter the following commands in the Configure mode:

Specify a TACACS server.	<b>tacacs set host</b> <hostname or IP-addr>
Set the TACACS time to wait for a TACACS server reply.	<b>tacacs set timeout</b> <number>
Determine SSR action if no server responds.	<b>tacacs set last-resort password succeed</b>
Enable TACACS.	<b>tacacs enable</b>

### Monitor TACACS

You can monitor TACACS configuration and statistics within the SSR.

To monitor TACACS, enter the following commands in Enable mode:

Show TACACS server statistics.	<b>tacacs show stats</b>
Show all TACACS parameters.	<b>tacacs show all</b>

### Configure TACACS Plus

You can secure login or Enable mode access to the SSR by enabling a TACACS Plus client. A TACACS Plus server responds to the SSR TACACS Plus client to provide authentication.

You can configure up to five TACACS Plus server targets on the SSR. A timeout is set to tell the SSR how long to wait for a response from TACACS Plus servers.

To configure TACACS Plus security, enter the following commands in Configure mode:

Specify a TACACS Plus server.	<b>tacacs-plus set host</b> <hostname or IP-addr>
Set the TACACS Plus time to wait for a TACACS Plus server reply.	<b>tacacs-plus set timeout</b> <number>
Determine the SSR action if no server responds.	<b>tacacs-plus set last-resort password succeed</b>
Enable TACACS Plus.	<b>tacacs-plus enable</b>

### Monitor TACACS Plus

You can monitor TACACS Plus configuration and statistics within the SSR.

To monitor TACACS Plus, enter the following commands in Enable mode:

Show TACACS Plus server statistics.	<b>tacacs-plus show stats</b>
Show all TACACS Plus parameters.	<b>tacacs-plus show all</b>

## Configure Passwords

The SSR provides password authentication for accessing the User and Enable modes. If TACACS is not enabled on the SSR, only local password authentication is performed.

To configure SSR passwords, enter the following commands in Configure mode:

Set User mode password.	<b>system set password login</b> <string>
Set Enable mode password.	<b>system set password enable</b> <string>

## Layer-2 Security Filters

Layer-2 security filters on the SSR allow you to configure ports to filter specific MAC addresses. When defining a Layer-2 security filter, you specify to which ports you want the filter to apply. You can specify the following security filters:

- Address filters
 

These filters block traffic based on the frame's source MAC address, destination MAC address, or both source and destination MAC addresses in flow bridging mode. Address filters are always configured and applied to the input port.
- Port-to-address lock filters
 

These filters prohibit a user connected to a locked port or set of ports from using another port.
- Static entry filters
 

These filters allow or force traffic to go to a set of destination ports based on a frame's source MAC address, destination MAC address, or both source and destination MAC addresses in flow bridging mode. Static entries are always configured and applied at the input port.
- Secure port filters
 

A secure filter shuts down access to the SSR based on MAC addresses. All packets received by a port are dropped. When combined with static entries, however, these filters can be used to drop all received traffic but allow some frames to go through.

## Configuring Layer-2 Address Filters

If you want to control access to a source or destination on a per-MAC address basis, you can configure an address filter. Address filters are always configured and applied to the input port. You can set address filters on the following:

- A source MAC address, which filters out any frame coming from a specific source MAC address.
- A destination MAC address, which filters out any frame destined to specific destination MAC address.
- A flow, which filters out any frame coming from a specific source MAC address that is also destined to a specific destination MAC address.

To configure Layer-2 address filters, enter the following commands in Configure mode:

Configure a source MAC based address filter.	<b>filters add address-filter name</b> <name> <b>source-mac</b> <MACaddr> <b>vlan</b> <VLAN-num> <b>in-port-list</b> <port-list>
Configure a destination MAC based address filter.	<b>filters add address-filter name</b> <name> <b>dest-mac</b> <MACaddr> <b>vlan</b> <VLAN-num> <b>in-port-list</b> <port-list>
Configure a Layer-2 flow address filter.	<b>filters add address-filter name</b> <name> <b>source-mac</b> <MACaddr> <b>dest-mac</b> <MACaddr> <b>vlan</b> <VLAN-num> <b>in-port-list</b> <port-list>

## Configuring Layer-2 Port-to-Address Lock Filters

Port address lock filters allow you to bind or “lock” specific source MAC addresses to a port or set of ports. Once a port is locked, only the specified source MAC address is allowed to connect to the locked port and the specified source MAC address is not allowed to connect to any other ports.

To configure Layer-2 port address lock filters, enter the following commands in Configure mode:

Configure a port address lock filter.	<b>filters add port-address-lock name</b> <name> <b>source-mac</b> <MACaddr> <b>vlan</b> <VLAN-num> <b>in-port-list</b> <port-list>
---------------------------------------	---

## Configuring Layer-2 Static Entry Filters

Static entry filters allow or force traffic to go to a set of destination ports based on a frame's source MAC address, destination MAC address, or both source and destination MAC addresses in flow bridging mode. Static entries are always configured and applied at the input port. You can set the following static entry filters:

- Source static entry, which specifies that any frame coming from source MAC address will be allowed or disallowed to go to a set of ports
- Destination static entry, which specifies that any frame destined to a specific destination MAC address will be allowed, disallowed, or forced to go to a set of ports
- Flow static entry, which specifies that any frame coming from a specific source MAC address that is destined to specific destination MAC address will be allowed, disallowed, or forced to go to a set of ports

To configure Layer-2 static entry filters, enter the following commands in Configure mode:

Configure a source static entry filter.	<b>filters add static-entry name &lt;name&gt; restriction allow disallow force source-mac &lt;MACaddr&gt; vlan &lt;VLAN-num&gt; in-port-list &lt;port-list&gt; out-port-list &lt;port-list&gt;</b>
Configure a destination static entry filter.	<b>filters add static-entry name &lt;name&gt; restriction allow disallow force dest-mac &lt;MACaddr&gt; vlan &lt;VLAN-num&gt; in-port-list &lt;port-list&gt; out-port-list &lt;port-list&gt;</b>

## Configuring Layer-2 Secure Port Filters

Secure port filters block access to a specified port. You can use a secure port filter by itself to secure unused ports. Secure port filters can be configured as source or destination port filters. A secure port filter applied to a source port forces all incoming packets to be dropped on a port. A secure port filter applied to a destination port prevents packets from going out a certain port.

You can combine secure port filters with static entries in the following ways:

- Combine a source secure port filter with a source static entry to drop all received traffic but allow any frame coming from specific source MAC address to go through
- Combine a source secure port filter with a flow static entry to drop all received traffic but allow any frame coming from a specific source MAC address that is destined to specific destination MAC address to go through
- Combine a destination secure port with a destination static entry to drop all received traffic but allow any frame destined to specific destination MAC address go through

- Combine a destination secure port filter with a flow static entry to drop all received traffic but allow any frame coming from specific source MAC address that is destined to specific destination MAC address to go through

To configure Layer-2 secure port filters, enter the following commands in Configure mode:

Configure a source secure port filter.	<b>filters add secure-port name</b> <name> <b>direction source vlan</b> <VLAN-num> <b>in-port-list</b> <port-list>
Configure a destination secure port filter.	<b>filters add secure-port name</b> <name> <b>direction destination vlan</b> <VLAN-num> <b>in-port-list</b> <port-list>

## Monitor Layer-2 Security Filters

The SSR provides display of Layer-2 security filter configurations contained in the routing table.

To display security filter information, enter the following commands in Enable mode.

Show address filters.	<b>filters show address-filter</b> <b>[all-source all-destination all-flow]</b> <b>[source-mac &lt;MACaddr&gt; dest-mac &lt;MACaddr&gt;]</b> <b>[ports &lt;port-list&gt;] [vlan &lt;VLAN-num&gt;]</b>
Show port address lock filters.	<b>filters show port-address-lock ports</b> <b>[ports &lt;port-list&gt;] [vlan &lt;VLAN-num&gt;]</b> <b>[source-mac &lt;MACaddr&gt;]</b>
Show secure port filters.	<b>filters show secure-port</b>
Show static entry filters.	<b>filters show static-entry</b> <b>[all-source all-destination all-flow]</b> <b>ports &lt;port-list&gt; vlan &lt;VLAN-num&gt;</b> <b>[source-mac &lt;MACaddr&gt; dest-mac &lt;MACaddr&gt;]</b>

## Layer-2 Filter Examples

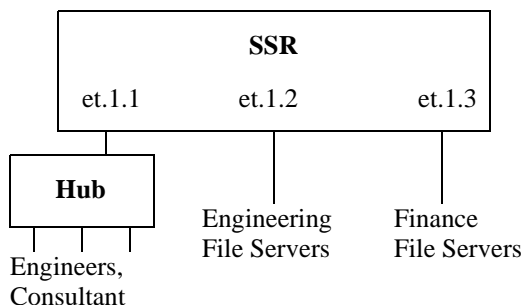

Figure 13. Source Filter Example

### Example 1: Address Filters

**Source filter:** The consultant is not allowed to access any file servers. The consultant is only allowed to interact with the engineers on the same Ethernet segment – port et.1.1. All traffic coming from the consultant’s MAC address will be dropped.

```
filters add address-filter name consultant source-mac 001122:334455
vlan 1 in-port-list et.1.1
```

**Destination filter:** No one from the engineering group (port et.1.1) should be allowed to access the finance server. All traffic destined to the finance server's MAC will be dropped.

```
filters add address-filter name finance dest-mac AABCC:DDEEFF vlan 1
in-port-list et.1.1
```

**Flow filter:** Only the consultant is restricted access to one of the finance file servers. Note that port et.1.1 should be operating in flow-bridging mode for this filter to work.

```
filters add address-filter name consult-to-finance source-mac
001122:334455 dest-mac AABCC:DDEEFF vlan 1 in-port-list et.1.1
```

### Static Entries Example

**Source static entry:** The consultant is only allowed to access the engineering file servers on port et.1.2.

```
filters add static-entry name consultant source-mac 001122:334455 vlan 1
in-port-list et.1.1 out-port-list et.1.2 restriction allow
```



**Destination static entry:** Restrict "login multicasts" originating from the engineering segment (port et.1.1) from reaching the finance servers.

```
filters add static-entry name login-mcasts dest-mac 010000:334455 vlan 1
  in-port-list et.1.1 out-port-list et.1.3 restriction disallow
```

or

```
filters add static-entry name login-mcasts dest-mac 010000:334455 vlan 1
  in-port-list et.1.1 out-port-list et.1.2 restriction allow
```

**Flow static entry:** Restrict "login multicasts" originating from the consultant from reaching the finance servers.

```
filters add static-entry name consult-to-mcasts source-mac
  001122:334455 dest-mac 010000:334455 vlan 1 in-port-list et.1.1
  out-port-list et.1.3 restriction disallow
```

### Port-to-Address Lock Examples

You have configured some filters for the consultant on port et.1.1. If the consultant plugs his laptop into a different port, he will bypass the filters. To lock him to port et.1.1, use the following command:

```
filters add port-address-lock name consultant source-mac 001122:334455
  vlan 1 in-port-list et.1.1
```

**Note:** If the consultant's MAC is detected on a different port, all of its traffic will be blocked.

### Example 2 : Secure Ports

**Source secure port:** To block all engineers on port 1 from accessing all other ports, enter the following command:

```
filters add secure-port name engineers direction source vlan 1
  in-port-list et.1.1
```

To allow ONLY the engineering manager access to the engineering servers, you must "punch" a hole through the secure-port wall. A "source static-entry" overrides a "source secure port".

```
filters add static-entry name eng_mgr source-mac 080060:123456 vlan 1
  in-port-list et.1.1 out-port-list et.1.2 restriction allow
```

**Destination secure port:** To block access to all file servers on all ports from port et.1.1 use the following command:

```
filters add secure-port name engineers direction dest vlan 1
in-port-list et.1.1
```

To allow all engineers access to the engineering servers, you must "punch" a hole through the secure-port wall. A "dest static-entry" overrides a "dest secure port".

```
filters add static-entry name eng-server dest-mac 080060:abcdef vlan 1
in-port-list et.1.1 out-port-list et.1.2 restriction allow
```

## Layer-3 Access Control Lists (ACLs)

### Layer-3 & Layer-4 Traffic Filters (Access Control List)

Access Control Lists (ACLs) allow you to restrict Layer-3/4 traffic going through the router. Each ACL or each list consists of one or more rules describing a particular type of IP or IPX traffic. An ACL can be simple, consisting of only one rule, or complicated with many rules. Each rule tells the router to either permit or deny the packet that matches the rule's packet description.

### Anatomy of an ACL Rule

Each ACL is identified by a name. The name can be a meaningful string, such as *denyftp* or *noweb* or it can be a number such as 100 or 101.

Each rule has an action, that is, to permit or to deny the packet if a packet satisfies the criterion defined by the rule.

A criterion describes one or more characteristics about a packet. In an ACL rule, these characteristics are described as fields of a rule. Not all characteristics (fields) of a packet (rule) need to be specified. If a particular field is not specified, it is treated as a wildcard or "don't care" condition. However, if a field is specified, that particular field will be matched against the packet. Each protocol can have a number of different fields to match. For example, TCP can use socket port numbers while IPX can use a network node address to define a rule. For IP, TCP and UDP ACLs, the following fields can be specified:

- Source IP address
- Destination IP address
- Source port number
- Destination port number

- Type of Service (TOS)

For IPX ACLs, the following fields can be specified:

- Source network address
- Destination network address
- Source IPX socket
- Destination IPX socket

When defining an ACL rule, each field in the rule is position sensitive. For example, for TCP, the source address must be followed by the destination address, followed by the source socket and the destination socket and so on. For example, the following describes the syntax of a TCP ACL:

```
acl name permit tcp source-addr dest-addr source-port dest-port tos
```

Not all the fields are required. If a field is not specified, it is treated as don't care. However, since each field is position sensitive, it may be necessary to "skip" some fields in order to specify a value for another field. To skip a field, the keyword **any** is used. For example, the following rule denies SMTP traffic between any two hosts:

```
acl nosmtp deny tcp any any smtp smtp
```

Note that in the above example, the **tos** field (Type of Service) is not specified and is treated as don't care. The keyword **any** is needed only to skip a don't care field in order to explicitly specify another field that is further down in the rule. If there are no other fields to specify, the keyword **any** is not really needed. For example, the following ACL permits all IP traffic to go through:

```
acl yesip permit ip
```

## Ordering of ACL Rules

For an ACL with multiple rules, the ordering of the rules is very important. When the router looks at an ACL to determine whether a packet should be forwarded or not, it goes through each rule in the ACL sequentially. When the router finds a rule that matches the packet, all subsequent rules are ignored. That is, a first match algorithm is used. The action defined by this ACL, to permit or deny, is used to forward or drop the packet. There are no hidden or implied ordering of these rules. Nor is there precedence attached to each field. The router simply goes down the list, one rule at a time until there is a match. Consequently, rules that are more specific (i.e. with more details) should always be listed

ahead of rules that are less specific. For example, the following ACL permits all TCP traffic except those from subnet 10.2.0.0/16:

```
ac1 101 deny tcp 10.2.0.0/16 any any any
ac1 101 permit tcp any any any any
```

When a TCP packet comes from subnet 10.2.0.0/16, it finds a match with the first rule. This causes the packet to be dropped. A TCP packet coming from other subnets will not match the first rule. Instead, it matches the second rule which allows the packet to go through.

If you were to reverse the order of the two rules:

```
ac1 101 permit tcp any any any any
ac1 101 deny tcp 10.2.0.0/16 any any any
```

then all TCP packets will be allowed to go through, including traffic from subnet 10.2.0.0/16. This is because TCP traffic coming from 10.2.0.0/16 will match the first rule and be allowed to go. The second rule will not be looked at since the first match determines the action on the packet.

## Implicit Deny Rule

At the end of each ACL, the system automatically appends an implicit deny rule. This implicit deny rule denies all traffic. For a packet that doesn't match any of the user specified rules, the implicit deny rule acts as a catch all rule. All packets match correctly with this rule. The default behavior for a packet that doesn't match any rules in an ACL can be either to permit or to deny. The SSR chooses to deny a packet as the default behavior. This is done for security reasons. If an ACL is misconfigured and a packet that should be allowed to go through is now blocked because of the implicit deny rule, the worse that could happen is inconvenience. On the other hand, if a packet that should not be allowed to go through is instead sent through, there is now a security breach. Basically, the implicit deny rule is the last line of defense against accidental mis-configuration of ACLs that could result in a security breach.

To describe how the implicit deny rule is used, considering the following example. Suppose someone created the following ACL:

```
ac1 101 permit ip 1.2.3.4/24
ac1 101 permit ip 4.3.2.1/24 any nntp
```

With the implicit deny rule, this ACL actually has three rules:

```
ac1 101 permit ip 1.2.3.4/24 any any any
ac1 101 permit ip 4.3.2.1/24 any nntp any
ac1 101 deny any any any any any
```

If a packet comes in and doesn't match the first two rules, the packet will be dropped. This is because the third rule (implicit deny) will match all packets.

Although the implicit deny rule seems obvious in the above example, this is not always the case. For example, consider the following ACL rule:

```
ac1 102 deny ip 10.1.20.0/24 any any any
```

If a packet comes in from a network other than 10.1.20.0/24, one might expect the packet to go through because it doesn't match the first rule. However, that is not the case because of the implicit deny rule. With the implicit deny rule attached, the rule looks like this:

```
ac1 102 deny ip 10.1.20.0/24 any any any
ac1 102 deny any any any any any
```

A packet coming from 10.1.20.0/24 will not match the first rule, but will match the implicit deny rule. As a result, no packets will be allowed to go through. Rule 1 is simply a subset of Rule 2. To allow packets from subnets other than 10.1.20.0/24 to go through, the administrator must explicitly define a rule to permit other packets to go through.

To fix the above example and let packets from other subnets enter the router, one must add a new rule to permit packets to go through:

```
ac1 101 deny ip 10.1.20.0/24 any any any
ac1 101 permit ip
ac1 101 deny any any any any any
```

The second rule will forward all packets that are not denied by the first rule.

Due to the nature of the implicit deny rule, when creating an ACL, one should take the approach where a firewall is elected to deny all traffic. "Holes" are then punched into the firewall to permit specific types of traffic, for example, traffic from a specific subnet or traffic from a specific application.

## Applying ACLs to Interfaces

Defining an ACL specifies what sort of traffic to permit or deny. However, an ACL has no effect unless it is applied to an interface. An ACL can be applied to examine either inbound or outbound traffic. Inbound traffic is traffic coming into the router. Outbound traffic is traffic going out of the router. For each interface, only one ACL can be applied for the same protocol in the same direction. For example, you cannot apply two or more IP ACLs to the same interface in the inbound direction. You can apply two ACLs to the same interface if one is for inbound traffic and one is for outbound traffic, but not in the same direction. However, this restriction does not prevent you from specifying many rules in an ACL. You just have to put all of these rules into one ACL and apply it to an interface.

When a packet comes into a router at an interface where an inbound ACL is applied, the router compares the packet with the rules specified by that ACL. If it is permitted, the packet is allowed into the router. If not, the packet is dropped. If that packet is to be forwarded to go out of another interface (that is, the packet is to be routed) then a second ACL check is possible. At the output interface, if an outbound ACL is applied, the packet will be compared with the rules specified in this outbound ACL. Consequently, it is possible for a packet to go through two separate checks, once at the inbound interface and once more at the outbound interface.

In general, you should try to apply ACLs at the inbound interfaces instead of the outbound interfaces. If a packet is to be denied, you want to drop the packet as early as possible, at the inbound interface. Otherwise, the router will have to process the packet, determine where the packet should go only to find out that the packet should be dropped at the outbound interface. In some cases, however, it may not be simple or possible for the administrator to know ahead of time that a packet should be dropped at the inbound interface. Nonetheless, for performance reason, whenever possible, one should create and apply an ACL to the inbound interface.

## Applying ACLs to Services

ACLs can also be created to permit or deny access to system services provided by the router; for example, HTTP server or Telnet server. This type of ACL is known as a Service ACL. By definition, a Service ACL is for controlling inbound packets to a service on the router. For example, you can grant Telnet server access from a few specific hosts or deny Web server access from a particular subnet. It is true that one can do the same thing with ordinary ACLs and apply them to all interfaces. However, the Service ACL is created specifically to control access to some of the services on the router. As a result, the syntax of a Service ACL is much simpler than that of the ordinary ACL.

**Note:** If a service does not have an ACL applied then that service is accessible to everyone. To control access to a service, an ACL must be used.

## ACL Logging

To see whether incoming packets are permitted or denied because of an ACL, one can enable ACL Logging when applying the ACL. When ACL Logging is turned on, the router prints out a message on the console about whether a packet is forwarded or dropped. If you have a Syslog server configured for the SSR then the same information will also be sent to the Syslog server.

Before enabling ACL Logging, one should consider its impact on performance. With ACL Logging enabled, the router prints out a message at the console before the packet is actually forwarded or dropped. Even if the console is connected to the router at a high baud rate, the delay caused by the console message is still significant. This can get worse if the console is connected at a low baud rate, for example, 1200 baud. Furthermore, if a Syslog server is configured then a Syslog packet must also be sent to the Syslog server,

creating additional delay. Therefore, one should consider the potential performance impact before turning on ACL Logging.

## Maintaining ACLs Offline Using TFTP or RCP

The SSR provides two mechanisms to maintain and manipulate ACLs. The traditional method used by some of the other popular routers require the use of TFTP or RCP. With this mechanism, the administrator is encouraged to create and modify ACLs on a remote host. The administrator can use his or her favorite editor to edit, delete, replace or reorder ACL rules in a file. Once the changes are made, the administrator can then download the ACLs to the router using TFTP or RCP and make them take effect on the running system.

The following example describes how one can use TFTP to help maintain ACLs on the SSR. Suppose the following ACL commands are stored in a file on some hosts:

```
no acl *
acl 101 deny tcp 10.11.0.0/16 10.12.0.0/16
acl 101 permit tcp 10.11.0.0 any
acl 101 apply interface ssr12 input
```

The first command, **no acl \***, negates all commands that start with the keyword, "acl". This tells the router to remove the application and the definition of any ACL. The administrator can be more selective if he or she wants to remove only ACL commands related to, for instance, ACL 101 by saying, **no acl 101 \***. The negation of all related ACL commands is important because it removes any potential confusion caused by the addition of new ACL rules to existing rules. Basically, the **no acl** command cleans up the system for the new ACL rules.

Once the negation command is executed, the second and the third commands proceed to redefine ACL 101. The final command applies the ACL to interface ssr12.

If the changes are accessible from a TFTP server, one can download and make the changes take effect by issuing commands like the following:

```
copy tftp://10.1.1.12/config/acl.changes to scratchpad
copy scratchpad to active
```

The first *copy* command downloads the file *acl.changes* from a TFTP server and puts the commands into the temporary configuration area, *scratchpad*. The administrator can re-examine the changes if necessary before committing the changes to the running system. The second *copy* command make the changes take effect by copying from the *scratchpad* to the active running system.

If the administrator needs to re-order or modify the ACL rules, one must make the changes in the *acl.changes* file on the remote host, download the changes and make them effective again.

## Maintaining ACLs Using the ACL Editor

In addition to the traditional method of maintaining ACLs using TFTP or RCP, the SSR provides a simpler and more user-friendly mechanism to maintain ACL: the ACL Editor.

The ACL Editor can only be accessed within Configure mode using the **acl-edit** command. You can specify the ACL you want to edit by specifying its name together with the **acl-edit** command. For example, to edit ACL "101", you issue the command **acl-edit 101**. The only restriction is that when you edit a particular ACL, you cannot add rules for a different ACL. You can only add new rules for the ACL that you are currently editing. When the editing session is over, that is, when you are done making changes to the ACL, you can save the changes and make them take effect immediately. Within the ACL editor, you can add new rules (**add** command), delete existing rules (**delete** command) and re-order the rules (**move** command). To save the changes, use the **save** command or simply exit the editor.

If you edit and save changes to an ACL that is currently being used or applied to an interface, the changes will take effect immediately. There is no need to remove the ACL from the interface before making changes and re-apply after changes are made. The whole process is automatic.

## Configure ACL

To configure an ACL, perform the following tasks:

1. Determine the access control criteria you want to impose on traffic going to or through the router.
2. Determine where (which interface) you want to set up these controls.

### Defining an IP ACL

To define an IP ACL, perform the following in the Configure mode:

Define an IP ACL.	<pre> <b>acl</b> &lt;name&gt; <b>permit deny</b> <b>ip tcp udp icmp igmp</b> &lt;srcaddr/mask&gt; <b>any</b> &lt;dstaddr/mask&gt; <b>any</b> </pre> <p><b>Note:</b> Additional fields depend on the protocol type you select.</p>
-------------------	---



### Defining an IPX ACL

To define an IPX ACL, perform the following in the Configure mode:

Define an IPX ACL.	<b>acl</b> <name> <b>permit deny ipx ipxrip ipxsap</b> <b>Note:</b> Additional fields depend on the protocol type you select.
--------------------	--

### Applying an ACL to an Interface

To apply an ACL to an interface, perform the following in the Configure mode:

Apply ACL to an interface.	<b>acl</b> <name> <b>apply interface</b> <Interface Name> <b>input output [logging [on off]]</b>
----------------------------	---

### Applying an ACL to a Service

To apply an ACL to a service, perform the following in the Configure mode:

Apply ACL to a service.	<b>acl</b> <name> <b>apply service</b> <Service Name> <b>[logging [on off]]</b>
-------------------------	--

### Edit an ACL with the ACL Editor

To edit an ACL, perform the following in the Configure mode:

Edit an ACL using the ACL Editor	<b>acl-edit</b> <acl name>
----------------------------------	----------------------------

## Monitoring Access Control Lists

The SSR provides display of ACL configurations contained in the system.

To display ACL information, enter the following command in Enable mode.

Show all ACLs.	<b>acl show all</b>
Show a specific ACL.	<b>acl show aclname</b> <Name>   <b>all</b>
Show an ACL on a specific interface.	<b>acl show interface</b> <Name>
Show ACLs on all IP interfaces.	<b>acl show interface all-ip</b>

Show ACLs on all IPX interfaces.	<code>acl show interface all-ipx</code>
Show static entry filters.	<code>acl show service</code>

# Chapter 11

## QoS Configuration Guide

### QoS & Layer-2/Layer-3/Layer-4 Flow Overview

The SSR allows network managers to identify traffic and set Quality of Service (QoS) policies without compromising wire speed performance. The SSR can guarantee bandwidth on an application by application basis, thus accommodating high-priority traffic even during peak periods of usage. QoS policies can be broad enough to encompass all the applications in the network, or relate specifically to a single host-to-host application flow.

Within the SSR, QoS policies are used to classify Layer-2, Layer-3, and Layer-4 traffic into the following priorities:

- Control
- High
- Medium
- Low

By assigning priorities to network traffic, you can ensure that critical traffic will reach its destination even if the exit ports for the traffic are experiencing greater-than-maximum utilization.

### Layer-2, Layer-3 & Layer-4 Flow Specification

For Layer-2 traffic, you can define a flow based on the MAC packet headers.

- The MAC fields are source MAC address, destination MAC address and VLAN IDs. A list of incoming ports can also be specified

For Layer-3 (IP and IPX) traffic, you can define “flows”, blueprints or templates of IP and IPX packet headers.

- The IP fields are source IP address, destination IP address, UDP/TCP source port, UDP/TCP destination port, TOS (Type of Service), transport protocol (TCP or UDP), and a list of incoming interfaces
- The IPX fields are source network, source node, destination network, destination node, source port, destination port, and a list of incoming interfaces

The flows specify the contents of these fields. If you do not enter a value for a field, a wildcard value (all values acceptable) is assumed for the field.

## Precedence for Layer-3 Flows

A precedence from 1 - 7 is associated with each field in a flow. The SSR uses the precedence value associated with the fields to break ties if packets match more than one flow. The highest precedence is 1 and the lowest is 7. Here is the default precedence of the fields:

- IP - destination port (1), destination address (2), source port (3), source IP address (4), TOS (5), interface (6), protocol (7)
- IPX - destination network (1), source network (2), destination node (3), source node (4), destination port (5), source port (6), interface (7)

Use the **qos precedence ip** and **qos precedence ipx** commands to change the default precedence.

## SSR Queuing Policies

You can use one of two queuing policies on the SSR:

- **strict priority** – assures the higher priorities of throughput but at the expense of lower priorities. For example, during heavy loads, low-priority traffic can be dropped to preserve throughput of control-priority traffic, and so on.
- **weighted fair queuing** – distributes priority throughput among the four priorities (control, high, medium, and low) based on percentages.

The SSR can use only one queuing policy at a time. The policy is used on the entire SSR. The default queuing policy is strict priority.

## Configure Layer-2 QoS

QoS policies applied to layer-2 flows allow you to assign priorities based on source and destination MAC addresses. A QoS policy set for a layer-2 flow allows you to classify the priority of traffic from:

- A specific source MAC address to a specific destination MAC address (use only when the port is in flow bridging mode)
- Any source MAC address to a specific destination MAC address

Before applying a QoS policy to a layer-2 flow, you must first determine whether a port is in address-bridging mode or flow-bridging mode. If a port operates in address-bridging mode (default) then you can specify the priority based on the destination MAC address and a VLAN ID. You can also specify a list of ports to apply the policy.

If a port operates in flow-bridging mode, the user can be more specific and configure priorities for frames that match both a source AND a destination MAC address and a VLAN ID. You can also specify a list of ports to apply the policy.

**Note:** In flow mode, you can also ignore the source MAC address and configure the priority based on the destination MAC address only.

When applying QoS to a layer-2 flow, priority can be assigned as follows:

- The frame gets assigned a priority within the switch. Select “low, medium, high or control”.
- The frame gets assigned a priority within the switch, AND if the exit ports are trunk ports, the frame is assigned an 802.1Q priority. Select a number from 0 to 7. The mapping of 802.1Q to internal priorities is the following: (0 = low) (1,2,3 =medium) (4,5,6 = high) (7 = control)

To set a QoS policy on a layer-2 flow, enter the following command in Configure mode:

Set a Layer-2 QoS policy.	<pre>qos set 12 name &lt;name&gt; source-mac &lt;MACaddr&gt; dest-mac &lt;MACaddr&gt; vlan &lt;vlanID&gt; in-port-list &lt;port-list&gt; priority control high medium low &lt;trunk-priority&gt;</pre>
---------------------------	--

## Configuring Layer-3 & Layer-4 QoS

QoS policies applied at layer-3 and 4 allow you to assign priorities based on specific fields in the IP and IPX headers. You can set QoS policies for IP flows based on source IP address, destination IP address, source TCP/UDP port, destination TCP/UDP port, type of service (TOS) and transport protocol (TCP or UCP). You can set QoS policies for IPX flows based on source network, source node, destination network, destination node, source port and destination port. A QoS policy set on an IP or IPX flow allows you to classify the priority of traffic based on:

- Layer-3 source-destination flows
- Layer-4 source-destination flows
- Layer-4 application flows

## Configuring IP QoS Policies

To configure an IP QoS policy, perform the following tasks:

1. Identify the Layer-3 or 4 flow and set the IP QoS policy.
2. Specify the precedence for the fields within an IP flow.

### Setting an IP QoS Policy

To set a QoS policy on an IP traffic flow, enter the following command in Configure mode:

Set an IP QoS policy	<b>qos set ip</b> <name> <priority> <srcaddr/mask> any <dstaddr/mask> any <srcport> any <dstport> any <tos> any <interface-list> any <protocol>
----------------------	---

### Specifying Precedence for an IP QoS Policy

To specify the precedence for an IP QoS policy, enter the following command in Configure mode:

Specify precedence for an IP QoS policy.	<b>qos precedence ip</b> [sip <num>] [dip <num>] [srcport <num>] [destport <num>] [tos <num>] [protocol <num>] [intf <num>]
--	---

## Configuring IPX QoS Policies

To configure an IPX QoS policy, perform the following tasks:

1. Identify the Layer-3 or 4 flow and set the IPX QoS policy.
2. Specify the precedence for the fields within an IPX flow.

### Setting an IPX QoS Policy

To set a QoS policy on an IPX traffic flow, enter the following command in Configure mode:

Set an IPX QoS policy.	<b>qos set ipx</b> <name> <priority> <srcnet> any <srcmask> any <srcport> any <dstnet> any <dstmask> any <dstport> any <interface-list> any
------------------------	---

### Specifying Precedence for an IPX QoS Policy

To specify the precedence for an IPX QoS policy, enter the following command in Configure mode:

Specify precedence for an IPX QoS policy.	<b>qos precedence ipx</b> [srcnet <num>] [srcnode <num>] [srcport <num>] [dstnet <num>] [dstnode <num>] [dstport <num>] [intf <num>]
---	--

## Configuring SSR Queuing Policy

The SSR queuing policy is set on a system-wide basis. The SSR default queuing policy is strict priority. To change the queuing policy to weighted-fair queuing on the SSR, enter the following command in Configure mode:

Set queuing policy to weighted-fair	<b>qos set queuing-policy weighted-fair</b>
-------------------------------------	---

If you want to revert the SSR queuing policy from weighted-fair to strict priority (default), enter the following command in Configure mode:

Revert the SSR queuing policy to strict priority.	<b>negate</b> <line within active-configuration containing qos set queuing-policy weighted-fair>
---	--

### Allocating Bandwidth for a Weighted-Fair Queuing Policy

If you enable the weighted-fair queuing policy on the SSR, you can allocate bandwidth for the queues on the SSR. To allocate bandwidth for each SSR queue, enter the following command in Configure mode:

Allocate bandwidth for a weighted-fair queuing policy.	<b>qos set weighted-fair control</b> <percentage> high <percentage> medium <percentage> low <percentage>
--	--

## Monitoring QoS

The SSR provides display of QoS statistics and configurations contained in the SSR.

To display QoS information, enter the following command in Enable mode:

Show all IP QoS flows	<b>qos show ip</b>
Show all IPX QoS flows.	<b>qos show ipx</b>
Show all Layer-2 QoS flows.	<b>qos show 12 all-destination all-flow ports &lt;port-list&gt; vlan &lt;vlanID&gt; source-mac &lt;MACaddr&gt; dest-mac &lt;MACaddr&gt;</b>



# Chapter 12

## Performance Monitoring Guide

### Performance Monitoring Overview

The SSR is a full wire-speed layer-2, 3 and 4 switching router. As packets enter the SSR, layer-2, 3, and 4 flow tables are populated on each line card. The flow tables contain information on performance statistics and traffic forwarding. Thus the SSR provides the capability to monitor performance at Layer 2, 3, and 4. Layer-2 performance information is accessible to SNMP through MIB-II and can be displayed by using the **l2-tables** command in the CLI. Layer-3 and 4 performance statistics are accessible to SNMP through RMON/RMON2 and can be displayed by using the **statistics show** command in the CLI. In addition to the monitoring commands listed, you can find more monitoring commands listed in each chapter of the *SmartSwitch Router User Reference Manual*.

To access statistics on the SSR, enter the following commands in Enable mode:

Show DVMRP routes.	<b>dvmrp show routes</b>
Show HTTP statistics.	<b>http show statistics</b>
Show all TCP/UDP connections and services.	<b>ip show connections</b>
Show all IP routes.	<b>ip show routes</b>
Show all IPX routes.	<b>ipx show tables routing</b>
Show all MAC addresses currently in the L2 tables.	<b>l2-tables show all-macs</b>
Show info about MACs residing in a port's L2 table.	<b>l2-tables show port-macs</b> <i>&lt;port-list&gt;</i>

Show all L2 flows (for ports in flow-bridging mode).	<b>12-tables show all-flows</b>
Show information about the master MAC table.	<b>12-tables show mac-table-stats</b>
Show information about a particular MAC address.	<b>12-tables show mac</b>
Show info about multicasts registered by IGMP.	<b>12-tables show igmp-mcast-registrations</b>
Show whether IGMP is on or off on a VLAN.	<b>12-tables show vlan-igmp-status</b>
Show info about MACs registered by the system.	<b>12-tables show bridge-management</b>
Show SNMP statistics.	<b>snmp show statistics</b>
Show ICMP statistics.	<b>statistics show icmp</b>
Show IP interface's statistics.	<b>statistics show ip</b>
Show unicast routing statistics.	<b>statistics show ip-routing</b>
Show IPX statistics.	<b>statistics show ipx</b>
Show IPX interface's statistics.	<b>statistics show ipx-interface</b>
Show IPX routing statistics.	<b>statistics show ipx-routing</b>
Show multicast statistics.	<b>statistics show multicast</b>
Show port error statistics.	<b>statistics show port-errors</b>
Show port normal statistics.	<b>statistics show port-stats</b>
Show RMON statistics.	<b>statistics show rmon</b>
Show traffic summary statistics.	<b>statistics show summary-stats</b>
Show TCP statistics.	<b>statistics show tcp</b>
Show UDP statistics.	<b>statistics show udp</b>
Show TACACS server statistics.	<b>tacacs show stats</b>
Show all VLANs.	<b>vlan list</b>

## Configuring the SSR for Port Mirroring

The SSR allows you to monitor port activity with Port Mirroring. Port Mirroring allows you to monitor the performance and activities of one or more ports on the SSR through just a single, separate port. While in Configure mode, you can configure your SSR for port mirroring with a simple command line like the following:

Configure Port Mirroring	<code>port mirroring monitor-port &lt;port number&gt; target-port &lt;port list&gt;</code>
--------------------------	--

**Note:** Port Mirroring is available for WAN ports, however, you cannot configure Port Mirroring on a port-by-port basis. (You can only configure Port Mirroring for the entire WAN card).



# Chapter 13

## Hot Swapping Line Cards and Control Modules

### Hot Swapping Overview

This chapter describes the hot swapping functionality of the SSR. Hot swapping is the ability to replace a line card or Control Module while the SSR is operating. Hot swapping allows you to remove or install line cards without switching off or rebooting the SSR. Swapped-in line cards are recognized by the SSR and begin functioning immediately after they are installed.

On the SSR 8000 and 8600, you can hot swap line cards and secondary control modules. On the SSR 8600, you can also hot swap the secondary switching fabric module.

This chapter provides instructions for the following tasks:

- Hot swapping line cards
- Hot swapping secondary Control Modules
- Hot swapping the secondary Switching Fabric Module (SSR 8600 only)

### Hot Swapping Line Cards

The procedure for hot swapping a line card consists of deactivating the line card, removing it from its slot in the SSR chassis, and installing a new line card in the slot.

## Deactivating the Line Card

To deactivate the line card, do one of the following:

- Press the Hot Swap button on the line card. The Hot Swap button is recessed in the line card's front panel. Use a pen or similar object to reach it.

When you press the Hot Swap button, the Offline LED lights. [Figure 14](#) shows the location of the Offline LED and Hot Swap button on a 1000 Base-SX line card.

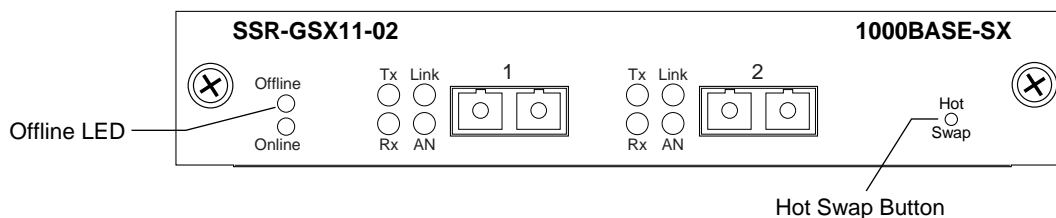

**Figure 14.** Location of Offline LED and Hot Swap button on a 1000 BASE-SX line card

- Use the **system hotswap out** command in the CLI. For example, to deactivate the line card in slot 7, enter the following command in Enable mode:

```
ctron-ssr-1# system hotswap out slot 7
```

After you enter this command, the Offline LED on the line card lights, and messages appear on the console indicating the ports on the line card are inoperative.

- Note:** If you have deactivated a line card and want to activate it again, simply pull it from its slot and push it back in again. (Make sure the Offline LED is lit before you pull out the line card.) The line card is activated automatically.

Alternately, if you have not removed a line card you deactivated with the **system hotswap out** command, you can reactivate it with the **system hotswap in** command. For example, to reactivate a line card in slot 7, enter the following command in Enable mode:

```
ctron-ssr-1# system hotswap in slot 7
```

## Removing the Line Card

To remove a line card from the SSR:

- Make sure the Offline LED on the line card is lit.



**Warning:** Do not remove the line card unless the Offline LED is lit. Doing so can cause the SSR to crash.

2. Loosen the captive screws on each side of the line card.
3. Carefully remove the line card from its slot in the SSR chassis.

## Installing a New Line Card

### To install a new line card:

1. Slide the line card all the way into the slot, firmly but gently pressing the line card fully in place to ensure that the pins on the back of the line card are completely seated in the backplane.

**Note:** Make sure the circuit card (and not the metal plate) is between the card guides. Check both the upper and lower tracks.

2. Tighten the captive screws on each side of the line card to secure it to the chassis.

Once the line card is installed, the SSR recognizes and activates it. The Online LED button lights.

## Hot Swapping One Type of Line Card With Another

You can hot swap one type of line card with another type. For example, you can replace a 10/100BASE-TX line card with a 1000BASE-SX line card. The SSR can be configured to accommodate whichever line card is installed in the slot. When one line card is installed, configuration statements for that line card are used; when you remove the line card from the slot and replace it with a different type, configuration statements for the new line card take effect.

To set this up, you include configuration statements for **both** line cards in the SSR configuration file. The SSR determines which line card is installed in the slot and uses the appropriate configuration statements.

For example, you may have an SSR with a 10/100BASE-TX line card in slot 7 and want to hot swap it with a 1000BASE-SX line card. If you include statements for both line cards in the SSR configuration file, the statements for the 1000BASE-SX take effect immediately after you install it in slot 7.

## Hot Swapping a Secondary Control Module

If you have a secondary control module installed on the SSR, you can hot swap it with another Control Module or line card.

**Note:** You can only hot swap an **inactive** Control Module. You should never remove the active Control Module from the SSR. Doing so will crash the system.

The procedure for hot swapping a control module is similar to the procedure for hot swapping a line card. You must deactivate the Control Module, remove it from the SSR, and insert another Control Module or line card in the slot.

## Deactivating the Control Module

### To deactivate the Control Module:

1. Determine which is the secondary Control Module.

Control Modules can reside in slot CM or slot CM/1 on the SSR. Usually slot CM contains the primary Control Module, and slot CM/1 contains the secondary Control Module. On the primary Control Module, the Online LED is lit, and on the secondary Control Module, the Offline LED is lit.

**Note:** The Offline LED on the Control Module has a different function from the Offline LED on a line card. On a line card, it means that the line card has been deactivated. On a Control Module, a lit Offline LED means that it is standing by to take over as the primary Control Module if necessary; it **does not** mean that the Control Module has been deactivated.

2. Press the Hot Swap button on the secondary Control Module.

When you press the Hot Swap button, all the LEDs on the Control Module (including the Offline LED) are deactivated. [Figure 15](#) shows the location of the Offline LED and Hot Swap button on a Control Module.

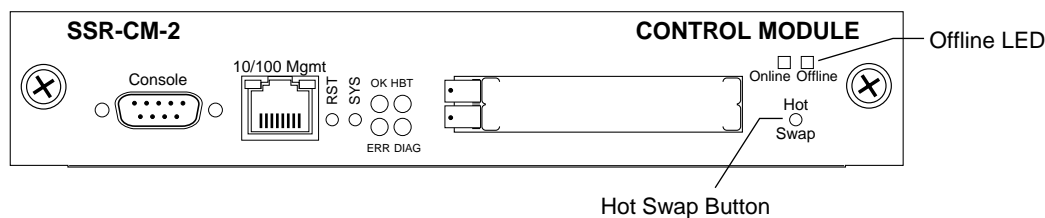

Figure 15. Location of Offline LED and Hot Swap button on a Control Module

## Removing the Control Module

### To remove a Control Module from the SSR:

1. Make sure that **none** of the LEDs on the Control Module are lit.
2. Loosen the captive screws on each side of the Control Module.
3. Carefully remove the Control Module from its slot in the SSR chassis.



## Installing the Control Module

**To install a new Control Module or line card into the slot:**

**Note:** You can install either a line card or a Control Module in slot CM/1, but you can install **only** a Control Module in slot CM.

1. Slide the Control Module or line card all the way into the slot, firmly but gently pressing it fully in place to ensure that the pins on the back of the card are completely seated in the backplane.

**Note:** Make sure the circuit card (and not the metal plate) is between the card guides. Check both the upper and lower tracks.

2. Tighten the captive screws on each side of the Control Module or line card to secure it to the chassis.

On a line card, the Online LED lights, indicating it is now active.

On a secondary Control Module, the Offline LED lights, indicating it is standing by to take over as the primary Control Module if necessary.

## Hot Swapping a Switching Fabric Module (SSR 8600 only)

The SSR 8600 has slots for two Switching Fabric Modules. While the SSR 8600 is operating, you can install a second Switching Fabric Module. If two Switching Fabric Modules are installed, you can hot swap one of them.

When you remove one of the Switching Fabric Modules, the other goes online and stays online until it is removed or the SSR 8600 is powered off. When the SSR 8600 is powered on again, the Switching Fabric Module in slot "Fabric 1", if one is installed there, becomes the active Switching Fabric Module.



**Warning:** You can only hot swap a Switching Fabric Module if two are installed on the SSR 8600. If only one Switching Fabric Module is installed, and you remove it, the SSR 8600 will crash.

The procedure for hot swapping a Switching Fabric Module is similar to the procedure for hot swapping a line card or Control Module. You deactivate the Switching Fabric Module, remove it from the SSR, and insert another Switching Fabric Module in the slot.

**Note:** You cannot deactivate the Switching Fabric Module with the **system hotswap** command.

**To deactivate the Switching Fabric Module:**

1. Press the Hot Swap button on the Switching Fabric Module you want to deactivate.

The Online LED goes out and the Offline LED lights. Figure 16 shows the location of the Offline LED and Hot Swap button on a Switching Fabric Module.



**Figure 16. Location of Offline LED and Hot Swap button on a Switching Fabric Module**

**To remove the Switching Fabric Module:**

1. Loosen the captive screws on each side of the Switching Fabric Module.
2. Pull the metal tabs on the Switching Fabric Module to free it from the connectors holding it in place in the chassis.
3. Carefully remove the Switching Fabric Module from its slot.

**To install a Switching Fabric Module:**

1. Slide the Switching Fabric Module all the way into the slot, firmly but gently pressing to ensure that the pins on the back of the module are completely seated in the backplane.

**Note:** Make sure the circuit card (and not the metal plate) is between the card guides. Check both the upper and lower tracks.

2. Tighten the captive screws on each side of the Switching Fabric Module to secure it to the chassis.

# Chapter 14

## VRRP Configuration Guide

### VRRP Overview

This chapter explains how to set up and monitor the Virtual Router Redundancy Protocol (VRRP) on the SSR. VRRP is defined in RFC 2338.

End host systems on a LAN are often configured to send packets to a statically configured default router. If this default router becomes unavailable, all the hosts that use it as their first hop router become isolated on the network. VRRP provides a way to ensure the availability of an end host's default router.

This is done by assigning IP addresses that end hosts use as their default route to a "virtual router." A Master router is assigned to forward traffic designated for the virtual router. If the Master router should become unavailable, a Backup router takes over and begins forwarding traffic for the virtual router. As long as one of the routers in a VRRP configuration is up, the IP addresses assigned to the virtual router are always available and the end hosts can send packets to these IP addresses without interruption.

### Configuring VRRP

This section presents three sample VRRP configurations:

- A basic VRRP configuration with one virtual router
- A symmetrical VRRP configuration with two virtual routers
- A multi-backup VRRP configuration with three virtual routers

## Basic VRRP Configuration

Figure 17 shows a basic VRRP configuration with a single virtual router. Routers R1 and R2 are both configured with one virtual router (VRID=1). Router R1 serves as the Master and Router R2 serves as the Backup. The four end hosts are configured to use 10.0.0.1/16 as the default route. IP address 10.0.0.1/16 is associated with virtual router VRID=1.

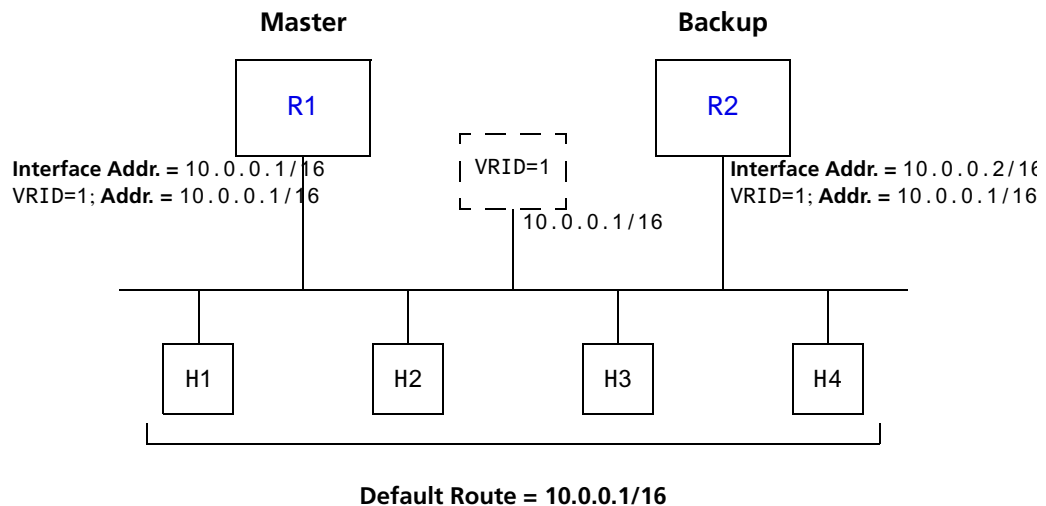

Figure 17. Basic VRRP Configuration

If Router R1 should become unavailable, Router R2 would take over virtual router VRID=1 and its associated IP addresses. Packets sent to 10.0.0.1/16 would go to Router R2. When Router R1 comes up again, it would take over as Master, and Router R2 would revert to Backup.

### Configuration of Router R1

The following is the configuration file for Router R1 in Figure 17.

```
1: interface create ip test address-netmask 10.0.0.1/16 port et.1.1
2: ip-redundancy create vrrp 1 interface test
3: ip-redundancy associate vrrp 1 interface test address 10.0.0.1/16
4: ip-redundancy start vrrp 1 interface test
```

Line 1 adds IP address 10.0.0.1/16 to interface test, making Router R1 the owner of this IP address. Line 2 creates virtual router VRID=1 on interface test. Line 3 associates IP address 10.0.0.1/16 with virtual router VRID=1. Line 4 starts VRRP on interface test.

In VRRP, the router that owns the IP address associated with the virtual router is the Master. Any other routers that participate in this virtual router are Backups. In this configuration, Router R1 is the Master for virtual router VRID=1 because it owns 10.0.0.1/16, the IP address associated with virtual router VRID=1.

### Configuration for Router R2

The following is the configuration file for Router R2 in [Figure 17](#).

```
1: interface create ip test address-netmask 10.0.0.2/16 port et.1.1
2: ip-redundancy create vrrp 1 interface test
3: ip-redundancy associate vrrp 1 interface test address 10.0.0.1/16
4: ip-redundancy start vrrp 1 interface test
```

The configuration for Router R2 is nearly identical to Router R1. The difference is that Router R2 does not own IP address 10.0.0.1/16. Since Router R2 does not own this IP address, it is the Backup. It will take over from the Master if it should become unavailable.

## Symmetrical Configuration

[Figure 18](#) shows a VRRP configuration with two routers and two virtual routers. Routers R1 and R2 are both configured with two virtual routers (VRID=1 and VRID=2).

Router R1 serves as:

- Master for VRID=1
- Backup for VRID=2

Router R2 serves as:

- Master for VRID=2
- Backup for VRID=1

This configuration allows you to load-balance traffic coming from the hosts on the 10.0.0.0/16 subnet and provides a redundant path to either virtual router.

**Note:** This is the recommended configuration on a network using VRRP.

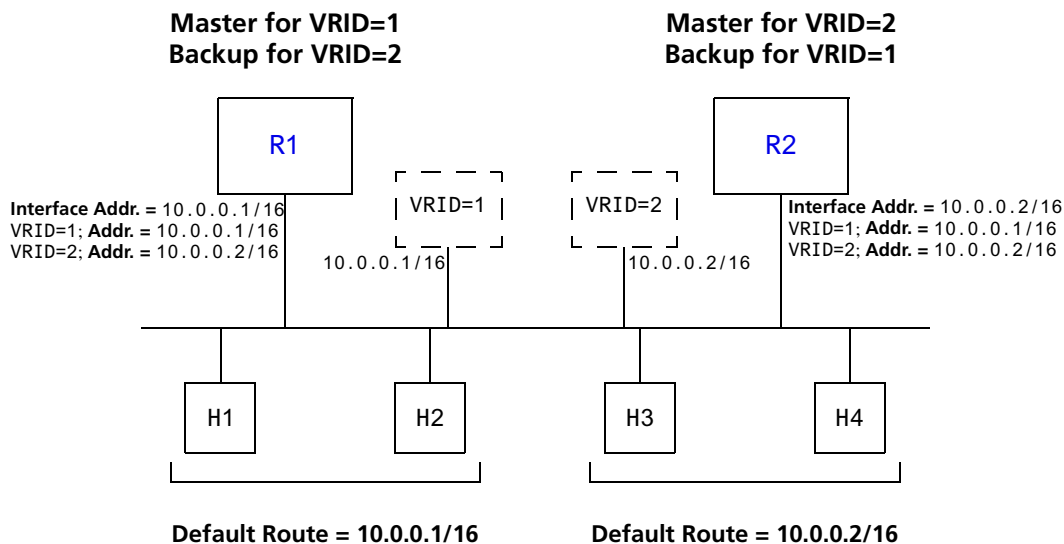

Figure 18. Symmetrical VRRP Configuration

In this configuration, half the hosts use 10.0.0.1/16 as their default route, and half use 10.0.0.2/16. IP address 10.0.0.1/16 is associated with virtual router VRID=1, and IP address 10.0.0.2/16 is associated with virtual router VRID=2.

If Router R1, the Master for virtual router VRID=1, goes down, Router R2 would take over the IP address 10.0.0.1/16. Similarly, if Router R2, the Master for virtual router VRID=2, goes down, Router R1 would take over the IP address 10.0.0.2/16.

### Configuration of Router R1

The following is the configuration file for Router R1 in [Figure 18](#).

```

1: interface create ip test address-netmask 10.0.0.1/16 port et.1.1
!
2: ip-redundancy create vrrp 1 interface test
3: ip-redundancy create vrrp 2 interface test
!
4: ip-redundancy associate vrrp 1 interface test address 10.0.0.1/16
5: ip-redundancy associate vrrp 2 interface test address 10.0.0.2/16
!
6: ip-redundancy start vrrp 1 interface test
7: ip-redundancy start vrrp 2 interface test

```

Router R1 is the owner of IP address 10.0.0.1/16. Line 4 associates this IP address with virtual router VRID=1, so Router R1 is the Master for virtual router VRID=1.

On line 5, Router R1 associates IP address 10.0.0.2/16 with virtual router VRID=2. However, since Router R1 does not own IP address 10.0.0.2/16, it is not the default Master for virtual router VRID=2.

### Configuration of Router R2

The following is the configuration file for Router R2 in [Figure 18](#).

```

1: interface create ip test address-netmask 10.0.0.2/16 port et.1.1
   !
2: ip-redundancy create vrrp 1 interface test
3: ip-redundancy create vrrp 2 interface test
   !
4: ip-redundancy associate vrrp 1 interface test address 10.0.0.1/16
5: ip-redundancy associate vrrp 2 interface test address 10.0.0.2/16
   !
6: ip-redundancy start vrrp 1 interface test
7: ip-redundancy start vrrp 2 interface test

```

On line 1, Router R2 is made owner of IP address 10.0.0.2/16. Line 5 associates this IP address with virtual router VRID=2, so Router R2 is the Master for virtual router VRID=2. Line 4 associates IP address 10.0.0.1/16 with virtual router VRID=1, making Router R2 the Backup for virtual router VRID=1.

### Multi-Backup Configuration

[Figure 19](#) shows a VRRP configuration with three routers and three virtual routers. Each router serves as a Master for one virtual router and as a Backup for each of the others. When a Master router goes down, one of the Backups takes over the IP addresses of its virtual router.

In a VRRP configuration where more than one router is backing up a Master, you can specify which Backup router takes over when the Master goes down by setting the priority for the Backup routers.

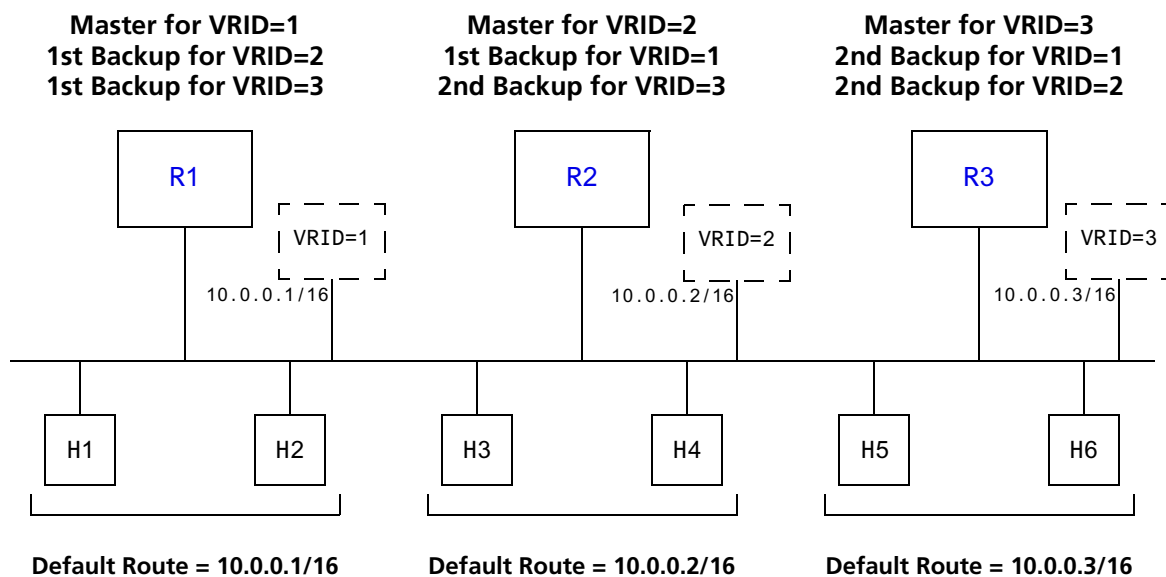

**Figure 19. Multi-Backup VRRP Configuration**

In this configuration, Router R1 is the Master for virtual router VRID=1 and the primary Backup for virtual routers VRID=2 and VRID=3. If Router R2 or R3 were to go down, Router R1 would assume the IP addresses associated with virtual routers VRID=2 and VRID=3.

Router R2 is the Master for virtual router VRID=2, the primary backup for virtual router VRID=1, and the secondary Backup for virtual router VRID=3. If Router R1 should fail, Router R2 would become the Master for virtual router VRID=1. If both Routers R1 and R3 should fail, Router R2 would become the Master for all three virtual routers. Packets sent to IP addresses 10.0.0.1/16, 10.0.0.2/16, and 10.0.0.3/16 would all go to Router R2.

Router R3 is the secondary Backup for virtual routers VRID=1 and VRID=2. It would become a Master router only if both Routers R1 and R2 should fail. In such a case, Router R3 would become the Master for all three virtual routers.



## Configuration of Router R1

The following is the configuration file for Router R1 in [Figure 19](#).

```

1: interface create ip test address-netmask 10.0.0.1/16 port et.1.1
   !
2: ip-redundancy create vrrp 1 interface test
3: ip-redundancy create vrrp 2 interface test
4: ip-redundancy create vrrp 3 interface test
   !
5: ip-redundancy associate vrrp 1 interface test address 10.0.0.1/16
6: ip-redundancy associate vrrp 2 interface test address 10.0.0.2/16
7: ip-redundancy associate vrrp 3 interface test address 10.0.0.3/16
   !
8: ip-redundancy set vrrp 2 interface test priority 200
9: ip-redundancy set vrrp 3 interface test priority 200
   !
10: ip-redundancy start vrrp 1 interface test
11: ip-redundancy start vrrp 2 interface test
12: ip-redundancy start vrrp 3 interface test

```

Router R1's IP address on interface test is 10.0.0.1. There are three virtual routers on this interface:

- VRID=1 – IP address=10.0.0.1/16
- VRID=2 – IP address=10.0.0.2/16
- VRID=3 – IP address=10.0.0.3/16

Since the IP address of virtual router VRID=1 is the same as the interface's IP address (10.0.0.1), then the router automatically becomes the address owner of virtual router VRID=1.

A priority is associated with each of the virtual routers. The priority determines whether the router will become the Master or the Backup for a particular virtual router. Priorities can have values between 1 and 255. When a Master router goes down, the router with the next-highest priority takes over the virtual router. If more than one router has the next-highest priority, the router that has the highest-numbered interface IP address becomes the Master.

If a router is the address owner for a virtual router, then its priority for that virtual router is 255 and cannot be changed. If a router is *not* the address-owner for a virtual-router, then its priority for that virtual router is 100 by default, and can be changed by the user.

Since Router R1 is the owner of the IP address associated with virtual router VRID=1, it has a priority of 255 (the highest) for virtual router VRID=1. Lines 8 and 9 set Router R1's priority for virtual routers VRID=2 and VRID=3 at 200. If no other routers in the VRRP configuration have a higher priority, Router R1 will take over as Master for virtual routers VRID=2 and VRID=3, should Router R2 or R3 go down.

The following table shows the priorities for each virtual router configured on Router R1.

Virtual Router	Default Priority	Configured Priority
VRID=1 – IP address=10.0.0.1/16	255 (address owner)	255 (address owner)
VRID=2 – IP address=10.0.0.2/16	100	200 (see line 8)
VRID=3 – IP address=10.0.0.3/16	100	200 (see line 9)

### Configuration of Router R2

The following is the configuration file for Router R2 in [Figure 19](#).

```

1: interface create ip test address-netmask 10.0.0.2/16 port et.1.1
   !
2: ip-redundancy create vrrp 1 interface test
3: ip-redundancy create vrrp 2 interface test
4: ip-redundancy create vrrp 3 interface test
   !
5: ip-redundancy associate vrrp 1 interface test address 10.0.0.1/16
6: ip-redundancy associate vrrp 2 interface test address 10.0.0.2/16
7: ip-redundancy associate vrrp 3 interface test address 10.0.0.3/16
   !
8: ip-redundancy set vrrp 1 interface test priority 200
9: ip-redundancy set vrrp 3 interface test priority 100
   !
10: ip-redundancy start vrrp 1 interface test
11: ip-redundancy start vrrp 2 interface test
12: ip-redundancy start vrrp 3 interface test

```

Line 8 sets the backup priority for virtual router VRID=1 to 200. Since this number is higher than Router R3's backup priority for virtual router VRID=1, Router R2 is the primary Backup and Router R3 is the secondary Backup for virtual router VRID=1.

On line 9, the backup priority for virtual router VRID=3 is set to 100. Since Router R1's backup priority for this virtual router is 200, Router R1 is the primary Backup and Router R2 is the secondary Backup for virtual router VRID=3.

The following table shows the priorities for each virtual router configured on Router R2.

Virtual Router	Default Priority	Configured Priority
VRID=1 – IP address=10.0.0.1/16	100	200 (see line 8)
VRID=2 – IP address=10.0.0.2/16	255 (address owner)	255 (address owner)
VRID=3 – IP address=10.0.0.3/16	100	100 (see line 9)

**Note:** Since 100 is the default priority, line 9, which sets the priority to 100, is actually unnecessary. It is included for illustration purposes only.

### Configuration of Router R3

The following is the configuration file for Router R3 in [Figure 19](#).

```

1: interface create ip test address-netmask 10.0.0.3/16 port et.1.1
   !
2: ip-redundancy create vrrp 1 interface test
3: ip-redundancy create vrrp 2 interface test
4: ip-redundancy create vrrp 3 interface test
   !
5: ip-redundancy associate vrrp 1 interface test address 10.0.0.1/16
6: ip-redundancy associate vrrp 2 interface test address 10.0.0.2/16
7: ip-redundancy associate vrrp 3 interface test address 10.0.0.3/16
   !
8: ip-redundancy set vrrp 1 interface test priority 100
9: ip-redundancy set vrrp 2 interface test priority 100
   !
10: ip-redundancy start vrrp 1 interface test
11: ip-redundancy start vrrp 2 interface test
12: ip-redundancy start vrrp 3 interface test

```

Lines 8 and 9 set the backup priority for Router R3 at 100 for virtual routers VRID=1 and VRID=2. Since Router R1 has a priority of 200 for backing up virtual router VRID=2, and Router R2 has a priority of 200 for backing up virtual router VRID=1, Router R3 is the secondary Backup for both virtual routers VRID=1 and VRID=2.

The following table shows the priorities for each virtual router configured on Router R3.

Virtual Router	Default Priority	Configured Priority
VRID=1 – IP address=10.0.0.1/16	100	100 (see line 8)
VRID=2 – IP address=10.0.0.2/16	100	100 (see line 9)
VRID=3 – IP address=10.0.0.3/16	255 (address owner)	255 (address owner)

**Note:** Since 100 is the default priority, lines 8 and 9, which set the priority to 100, are actually unnecessary. They are included for illustration purposes only.

### Additional Configuration

This section covers settings you can modify in a VRRP configuration, including backup priority, advertisement interval, pre-empt mode, and authentication key.

### Setting the Backup Priority

As described in “Multi-Backup Configuration” on page 199, you can specify which Backup router takes over when the Master router goes down by setting the priority for the Backup routers. To set the priority for a Backup router, enter the following command in Configure mode:

Set the Backup priority for a virtual router.	<b>ip-redundancy set vrrp &lt;vrid&gt; interface &lt;interface&gt; priority &lt;number&gt;</b>
---	--

The priority can be between 1 (lowest) and 254. The default is 100. The priority for the IP address owner is 255 and cannot be changed.

### Setting the Advertisement Interval

The VRRP Master router sends periodic advertisement messages to let the other routers know that the Master is up and running. By default, advertisement messages are sent once each second. To change the VRRP advertisement interval, enter the following command in Configure mode:

Set the Advertisement interval for a virtual router.	<b>ip-redundancy set vrrp &lt;vrid&gt; interface &lt;interface&gt; adv-interval &lt;seconds&gt;</b>
--	---

### Setting Pre-empt Mode

When a Master router goes down, the Backup with the highest priority takes over the IP addresses associated with the Master. By default, when the original Master comes back up again, it takes over from the Backup router that assumed its role as Master. When a VRRP router does this, it is said to be in *pre-empt mode*. Pre-empt mode is enabled by default on the SSR. You can prevent a VRRP router from taking over from a lower-priority Master by disabling pre-empt mode. To do this, enter the following command in Configure mode:

Disable pre-empt mode for a virtual router.	<b>ip-redundancy set vrrp &lt;vrid&gt; interface &lt;interface&gt; preempt-mode disabled</b>
---	--

**Note:** If the IP address owner is available, then it will always take over as the Master, regardless of whether pre-empt mode is on or off.

## Setting an Authentication Key

By default, no authentication of VRRP packets is performed on the SSR. You can specify a clear-text password to be used to authenticate VRRP exchanges. To enable authentication, enter the following command in Configure mode:

Set an authentication key for a virtual router.	<b>ip-redundancy set vrrp &lt;vrid&gt; interface &lt;interface&gt; auth-type text auth-key &lt;key&gt;</b>
---	--

where <key> is a clear-text password.

**Note:** The SSR does not currently support the IP Authentication Header method of authentication.

## Monitoring VRRP

The SSR provides two commands for monitoring a VRRP configuration: **ip-redundancy trace**, which displays messages when VRRP events occur, and **ip-redundancy show**, which reports statistics about virtual routers.

### ip-redundancy trace

The **ip-redundancy trace** command is used for troubleshooting purposes. This command causes messages to be displayed when certain VRRP events occur on the SSR. To trace VRRP events, enter the following commands in Enable mode:

Display a message when any VRRP event occurs. (Disabled by default.)	<b>ip-redundancy trace vrrp events enabled</b>
Display a message when a VRRP router changes from one state to another; for example Backup to Master. (Enabled by default.)	<b>ip-redundancy trace vrrp state-transitions enabled</b>
Display a message when a VRRP packet error is detected. (Enabled by default.)	<b>ip-redundancy trace vrrp packet-errors enabled</b>
Enable all VRRP tracing.	<b>ip-redundancy trace vrrp all enabled</b>

## ip-redundancy show

The **ip-redundancy show** command reports information about a VRRP configuration. To display VRRP information, enter the following commands in Enable mode.

Display information about all virtual routers.	<b>ip-redundancy show vrrp</b>
Display information about all virtual routers on a specified interface.	<b>ip-redundancy show vrrp interface &lt;interface&gt;</b>
Display detailed statistics about a specific virtual router	<b>ip-redundancy show vrrp &lt;vrid&gt; interface &lt;interface&gt; verbose</b>

## VRRP Configuration Notes

- The Master router sends keep-alive advertisements. The frequency of these keep-alive advertisements is determined by setting the Advertisement interval parameter. The default value is 1 second.
- If a Backup router doesn't receive a keep-alive advertisement from the current Master within a certain period of time, it will transition to the Master state and start sending advertisements itself. The amount of time that a Backup router will wait before it becomes the new Master is based on the following equation:

$$\text{Master-down-interval} = (3 * \text{advertisement-interval}) + \text{skew-time}$$

The skew-time depends on the Backup router's configured priority:

$$\text{Skew-time} = ((256 - \text{Priority}) / 256)$$

Therefore, the higher the priority, the faster a Backup router will detect that the Master is down. For example:

- Default advertisement-interval = 1 second
- Default Backup router priority = 100
- Master-down-interval = time it takes a Backup to detect the Master is down
  - = (3 \* adv-interval) + skew-time
  - = (3 \* 1 second) + ((256 - 100) / 256)
  - = 3.6 seconds

- If a Master router is manually rebooted, or if its interface is manually brought down, it will send a special keep-alive advertisement that lets the Backup routers that a new Master is needed immediately.

- A virtual router will respond to ARP requests with a virtual MAC address. This virtual MAC depends on the virtual router ID:

virtual MAC address = 00005E:0001XX

where XX is the virtual router ID

This virtual MAC address is also used as the source MAC address of the keep-alive Advertisements transmitted by the Master router.

- If multiple virtual routers are created on a single interface, the virtual routers must have unique identifiers. If virtual routers are created on different interfaces, you can reuse virtual router IDs .

For example, the following configuration is valid:

```
ip-redundancy create vrrp 1 interface test-A
ip-redundancy create vrrp 1 interface test-B
```

- As specified in RFC 2338, a Backup router that has transitioned to Master will not respond to pings, accept telnet sessions, or field SNMP requests directed at the virtual router's IP address.

Not responding allows network management to notice that the original Master router (i.e., the IP address owner) is down.

## Free Manuals Download Website

<http://myh66.com>

<http://usermanuals.us>

<http://www.somanuals.com>

<http://www.4manuals.cc>

<http://www.manual-lib.com>

<http://www.404manual.com>

<http://www.luxmanual.com>

<http://aubethermostatmanual.com>

Golf course search by state

<http://golfingnear.com>

Email search by domain

<http://emailbydomain.com>

Auto manuals search

<http://auto.somanuals.com>

TV manuals search

<http://tv.somanuals.com>