

# Reciprocating Liquid Chillers (60 Hz)

All 208/230-volt units have extended-voltage compressor motors.

All units have suction-cutoff unloading system.

## CONTENTS

	Page
<b>SAFETY CONSIDERATIONS</b> .....	1
<b>INSTALLATION</b> .....	1-6
<b>Step 1 — Inspect Shipment</b> .....	1
<b>Step 2 — Rig and Place Unit</b> .....	1
• RIGGING	
• PLACEMENT	
<b>Step 3 — Check Compressor Mounting and Connections</b> .....	3
• SERVICE ACCESS	
<b>Step 4 — Make Piping Connections</b> .....	3
• CONDENSER DESCRIPTION	
• CONDENSER PIPING	
• COOLER DESCRIPTION	
• COOLER PIPING	
<b>Step 5 — Make Electrical Connections</b> .....	4
• ELECTRICAL BOX, CONTROL SECTION	
• UNBALANCED 3-PHASE SUPPLY VOLTAGE	
• ELECTRICAL BOX, POWER SECTION	
<b>START-UP AND SERVICE</b> .....	6
<b>Initial Check</b> .....	6
<b>Check Refrigerant Charge</b> .....	6
• LIQUID CHARGING METHOD	
<b>Check Oil Charge</b> .....	7
• TO ADD OIL	
• TO REMOVE OIL	
<b>START-UP</b> .....	7-10
<b>Check Refrigerant Feed Components</b> .....	7
• THERMOSTATIC EXPANSION VALVE	
• FILTER DRIER	
• MOISTURE-LIQUID INDICATOR	
• LIQUID-LINE SERVICE VALVE	
• LIQUID-LINE SOLENOID VALVE	
• PRESSURE RELIEF DEVICES	
• CHECK VALVE	
<b>Check Compressor Protection Devices</b> .....	8
• CIRCUIT BREAKER	
• MOTOR OVERTEMPERATURE THERMOSTAT	
• CRANKCASE HEATER	
• TIME GUARD® CONTROL	
• FOUR-FUNCTION TIMER	
• OIL PRESSURE SAFETY SWITCH (OPS)	
<b>Check Unit Safety Devices</b> .....	9
• SAFETY THERMOSTAT	
• HIGH-PRESSURE SWITCH	
• LOW-PRESSURE SWITCH	
<b>Check Capacity Control System</b> .....	10
• DESCRIPTION	
• 3-STEP TEMPERATURE CONTROLLER	
• DESIGN SET POINT ADJUSTMENT	
• CYLINDER UNLOADING SYSTEM	

	Page
<b>UNIT OPERATION</b> .....	10-11
<b>Control Power</b> .....	10
<b>Control Sequence</b> .....	11
<b>Unit Stoppage and Restart</b> .....	11
<b>SERVICING COOLER</b> .....	11-13
<b>Tube Plugging</b> .....	12
<b>Retubing</b> .....	12
<b>Tightening Cooler Head Bolts</b> .....	12
• GASKET PREPARATION	
• BOLT TORQUES	
• BOLT TIGHTENING SEQUENCE	
<b>TROUBLESHOOTING GUIDE</b> .....	14,15

## SAFETY CONSIDERATIONS

Installation, start-up and servicing of this equipment can be hazardous due to system pressures, electrical components and equipment location (roofs, elevated structures, etc.).

Only trained, qualified installers and service mechanics should install, start-up and service this equipment.

When working on the equipment, observe precautions in the literature, tags, stickers and labels attached to the equipment and any other safety precautions that apply.

- Follow all safety codes.
- Wear safety glasses and work gloves.
- Use care in handling, rigging and setting bulky equipment.

**WARNING:** Be sure power to equipment is shut off before performing maintenance or service.

## INSTALLATION

### Step 1 — Inspect Shipment

Inspect unit for damage or missing parts. If damage is detected, or if shipment is incomplete, file a claim immediately with the shipping company.

### Step 2 — Rig and Place Unit

#### RIGGING

On each end of cooler, a steel loop is provided for the preferred method of lifting unit. *Use spreader bars to keep cables away from compressor enclosure and control box.* If unit is to be moved by fork truck, use the following methods:

1. From front or rear, lift under the cooler rails. Unit can be either on or off skid.
2. When moving from ends, *leave unit on skid.* Lift from under skid.

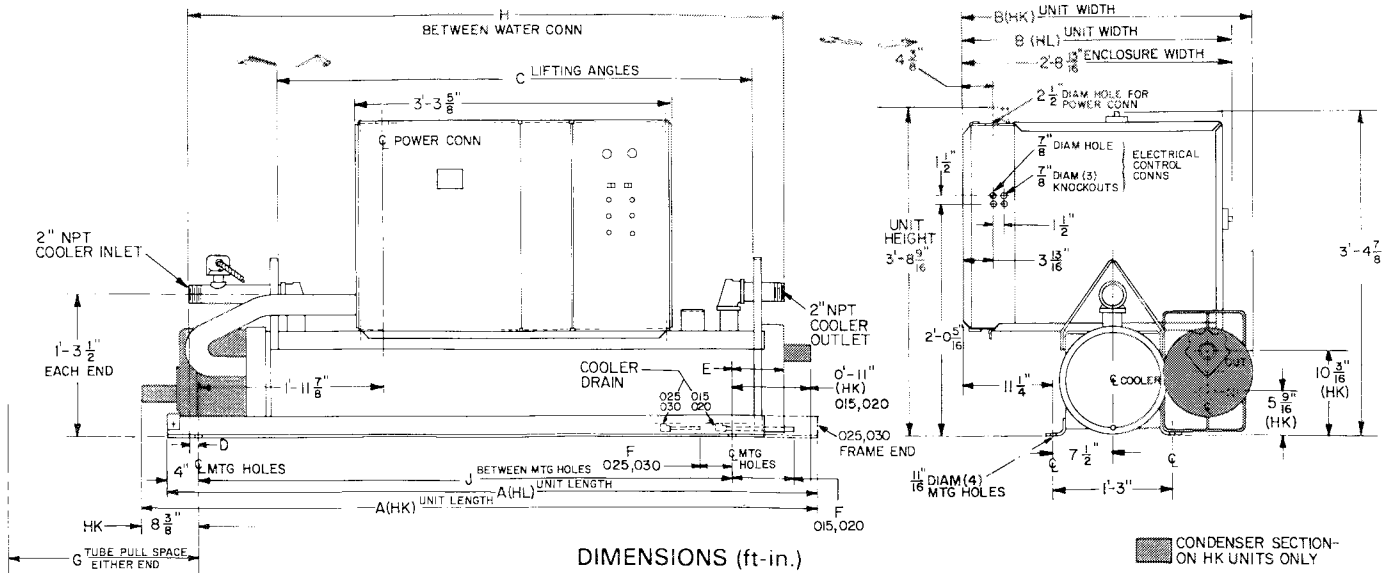

SIZE		015,020		025,030	
UNIT		HK	HL	HK	HL
A	Length	7- 2 <sup>1</sup> / <sub>4</sub>	6- 7 <sup>3</sup> / <sub>8</sub>	9-6 <sup>3</sup> / <sub>4</sub>	9- 2 <sup>5</sup> / <sub>16</sub>
B	Width	3-0	2-10 <sup>5</sup> / <sub>16</sub>	3-0	2-10 <sup>5</sup> / <sub>16</sub>
LIFTING ANGLE					
C	Inside	4-11 <sup>1</sup> / <sub>8</sub>	4-11 <sup>1</sup> / <sub>8</sub>	6-10	6-10
WATER CONN.					
D	Cooler Inlet	0- 1 <sup>5</sup> / <sub>16</sub>	0- 1 <sup>5</sup> / <sub>16</sub>	0-1	0-1
E	Cooler Outlet	0- 6 <sup>1</sup> / <sub>2</sub>	0- 6 <sup>1</sup> / <sub>2</sub>	0-6 <sup>3</sup> / <sub>8</sub>	0- 6 <sup>3</sup> / <sub>8</sub>
F	Cooler Drain	0- 8 <sup>1</sup> / <sub>2</sub>	0- 8 <sup>1</sup> / <sub>2</sub>	0-4	0-4
TUBE PULL SPACE					
G	Cooler	6-0	6-0	7-0	7-0
	Condenser	6-6	—	6-6	—
H		6-2 <sup>11</sup> / <sub>16</sub>		8-0 <sup>29</sup> / <sub>32</sub>	
J		5-6 <sup>7</sup> / <sub>8</sub>		8-6 <sup>3</sup> / <sub>32</sub>	

Fig. 1 — Unit Dimensions

Table 1 — Weight Distribution (lb)

UNIT 30( )	APPROX OPER WT	HK				HL				
		HK	HL	A	B	C	D	A	B	C
015	1637	1016	142	201	755	539	266	266	242	242
020	1787	1136	182	240	790	575	296	296	272	272
025	1980	1310	303	205	592	880	367	285	285	373
030	1985	1334	303	205	592	885	377	290	290	377

Location of mounting holes:

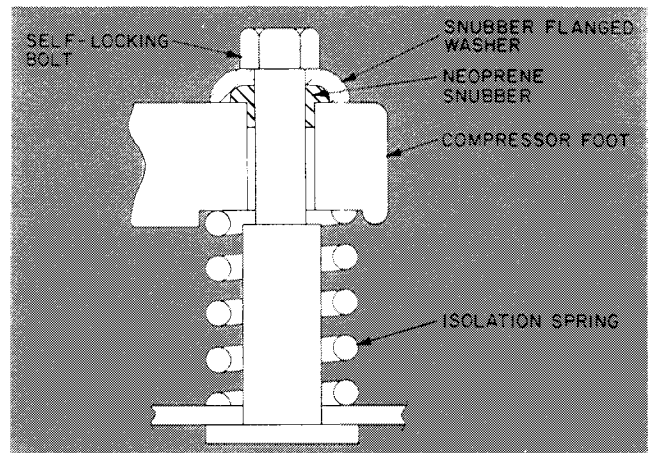
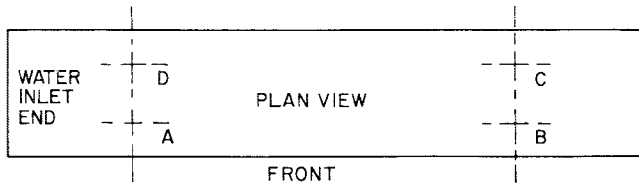

Fig. 2 — Compressor Mounting

To ensure safe moving, unit should remain on shipping skid until final placement. If unit is moved on rollers, use minimum of 3. Unit can also be dragged into final position (*must be on skid*).

When rolling or dragging, apply force to the skid, not the unit. Use care to avoid damage to piping and control box.

#### PLACEMENT

When unit is in final position, remove skid, level unit with a spirit level and bolt to floor or pad.

These units are not suitable for unprotected outdoor use.

Carrier recommends that these units be located in the basement or on the ground floor. However, if it is necessary to locate unit on an upper floor, be sure the structure has been designed to support the weight. If necessary, add structural support to floor. Also, be sure surface for installation is level. Refer to Fig. 1 for space requirements and Table 1 for weight distribution.

→ **Table 2 — Physical Data**

UNIT AND COMPRESSOR					
UNIT 30HK,HL		015	020	025	030
APPROXIMATE OPERATING WT (lb)	HK	1637	1787	1980	1985
	HL	1016	1136	1310	1334
REFRIGERANT (R-22) CHARGE (lb)	HK	34	38	40	45
	HL	Holding Charge			
COMPRESSOR 06*	HK	DC537	E2150	E7265	E7175
	HL	DC537	E2250	E7265	E7275
No. Cylinders		6	4	6	6
Oil Charge (pt)†		8.5	14	19	19
No. of Unloaders		2	1	2	2
Cap. Control Steps		3	3	3	3
CONDENSER, 09RP (HK)		022		027	
MAX DESIGN WORKING PRESSURE (psig)					
Cooler	Water Side	150			
	Refrig Side	235			
Condenser	Water Side	250			
	Refrig Side	385			

COOLER		
COOLER 10HA400	774	784
UNIT 30HK,HL	015,020	025,030
SHELL, Net Vol. (Gal.)‡	6.8	9.9
TUBES (Copper)		
	Internal Fins,	
	5/8-in. OD x 0.020 wall	
Number	81	81
Length (in.)	62.5	85.5
Eff. Outside Surface (sq ft)	66.3	91.7
REFRIGERANT CIRCUITS	1	1
CONNECTIONS (in.)		
Water	In and Out (MPT)	2
	Drain (MPT)	¾
Refrig	Liquid (ODM)	1.125
	Suction	1.625 ODM
WEIGHTS (lb)		
Cooler (Net)	354	446
Water	75	100
Refrigerant	8	12
Total	437	558

CONDENSER		
09RP	022	027
TUBES		
Copper, Integral Fins		
OD (in.)	¾	
Wall Thickness (in.)		
Plain End	0.043	
Finned Section	0.028	
Length (in.)	70 <sup>3/2</sup>	
Fins/in.	40	
Number**	36	44
Surface Area (sq ft)	Inside	32.9
	Outside	133.6
NO. WATER PASSES	3	
CONNECTIONS (in.)		
Water	In (IPS)	2½ Sched 40
	Out (IPS)	2½ Sched 40
Relief Valve Outlet (SAE)	⅝	
Water Regulating Valve	¼	
Liquid Outlet (ODF)	⅞	
Hot Gas (ODF)	1⅜	

\*Prefix: 2 = 1 electric unloader; C, 7 = 2 electric unloaders.  
 †See Check Oil Charge for Carrier-approved oil.  
 ‡Includes nozzles.  
 \*\*Includes 5 subcooler tubes.

Only electrical power connections and water connections for condenser and cooler are required for HK installation. Installation of HL units varies only in field piping required for the remote condenser.

**Step 3 — Check Compressor Mounting and Connections**

As shipped, compressor is held down by special self-locking bolts and plain lock washers. After unit is installed, remove self-locking bolts one at a time and reassemble with flanged washers and neoprene snubbers as shown in Fig. 2. Special flanged washers and neoprene snubbers are shipped in a cloth bag tied to one of the compressor feet. Tighten all 4 bolts. Then loosen each until flanged washer can be moved sideways with finger pressure.

**CAUTION:** Be sure interconnecting piping and electrical conduits are suspended free of contact with any adjacent walls, and be sure unit capillaries are not rubbing against anything.

**SERVICE ACCESS**

Remove combination top and back cover over compressor. Servicing can be performed from either top or back. For rear access, allow approximately 3 ft of clear space behind unit.

**Step 4 — Make Piping Connections**

**CONDENSER DESCRIPTION**

The condenser is a shell-and-tube type with removable heads for easy tube servicing. Condenser has an internal subcooler designed for 12- 15 F total liquid subcooling at average tower water conditions. For further condenser data refer to Table 2, Physical Data.

**CONDENSER PIPING**

*Provide a means for draining system in winter and for maintenance.*

**IMPORTANT:** Condenser water must enter at bottom for proper operation of the internal subcooler in condenser bottom (Fig. 1).

Keep water supply lines as short as possible. Size lines according to available head pressure, rather than by connection size, especially on cooling tower applications. Use flexible connections to reduce vibration transmission. Refer to Carrier System Design Manual, Part 3, Piping Design.

The 30HL units using air-cooled or evaporative condenser should have adequate means for head pressure control when operating below 60 F outdoor ambient temperature.

→ A water regulating valve *must* be installed on cooling tower application when any of the following conditions exists:

1. Low outdoor ambient temperatures affect head pressure.
2. Entering chilled water temperature is below 70 F.

3. A specific head pressure must be maintained.

Set water regulating valve to maintain design head pressure. Do not adjust to compensate for high head pressures caused by fouled condenser tubes, excess refrigerant or the presence of non-condensables. Due to changes in water temperature, it may be necessary to adjust valve seasonally. After adjusting for design head pressure, shut unit down. Water regulating valve should shut off flow of water in a few minutes. If it does not, raise head pressure setting. Make sure that capillary tube from water regulating valve is connected to condenser purge valve.

→ Instead of water regulating valve(s), a bypass arrangement may be used. This permits leaving condenser water to mix with condenser supply water, in order to maintain entering chilled water temperature above 70 F or an appropriate temperature necessary to maintain a specific head pressure.

**CAUTION:** Retighten all condenser head bolts before filling system with water. Torque bolts to a maximum of 45 ft-lb.

Water leaving condenser is under pressure and should not be connected directly into sewer lines. Check local codes. A 3/8-in. drain plug is located in the head at each condenser end.

Refer to PRESSURE RELIEF DEVICES and CHECK VALVE, page 8, concerning piping connections for these components.

### COOLER DESCRIPTION

The cooler is a direct-expansion type with removable heads and is partitioned for multi-pass refrigerant flow. Water flow across the tube bundle is directed by baffles designed for minimum water-pressure drop. The tubes have integral internal fins for maximum heat transfer efficiency.

Viewed from unit front, the return chilled water enters at left end of cooler and leaves at right end. The sensing bulb for the water temperature controller is in the return-water nozzle, the return-water temperature being the control point. The sensor for the low water-temperature cutout is located in the leaving-water nozzle.

The cooler is insulated with a flexible, closed-cell plastic foam insulation of suitable thickness. Water vapor cannot penetrate the cellular structure to condense either within cells or on the cooler shell. Thus, the insulation itself is a vapor barrier. Because of the toughness of insulation, a protective sheet metal covering is not necessary.

The standard cooler can be used for all glycol brines down to -20 F. However, for calcium or sodium chloride brines, it is important that the proper inhibitors be carefully selected for protection of the copper tubes. Refer to publications of the

Calcium Institute or the Mutual Chemical Division of Allied Chemical Corporation for information on corrosion control in calcium or sodium chloride systems.

### COOLER PIPING

Plan piping for minimum number of changes in elevation. Install manual or automatic vent valve at high points in line. Maintain system pressure by using a pressure tank or combination relief and reducing valve.

See Carrier System Design Manual, Part 3, Piping Design, for chilled-water piping details.

Install thermometers in entering and leaving water lines. Provide drain connections at all low points to permit complete drainage of system. Connect shutoff valve to drain line before operating unit. Install shutoff valves near entering and leaving water connections. Use flexible connections to reduce vibration transmission.

Insulate piping *after leak testing* to prevent heat transfer and sweating. Cover insulation with moisture seal.

A chilled water flow switch is factory installed in the line entering the cooler. See Table 3 for minimum recommended cooler and condenser flow rates and loop volume.

→ **Table 3 — Minimum Cooler and Condenser Water Flow Rates and Minimum Loop Volume**

UNIT	MINIMUM FLOW (GPM)		PRESSURE DROP (ft wg)		MINIMUM VOLUME† (Gal)
	Cooler	Condenser*	Cooler	Condenser	
30HK,HL015	25	34	3.2	2.1	47
020	32	34	5.1	2.1	60
025	38	41	5.5	2.1	81
030	38	41	5.5	2.1	88

\*Applicable to 30HK units only.  
†Minimum system water volumes:

Gallons = V x ARI Capacity in Tons

APPLICATION	V
Normal Air Conditioning	3
Process Type Cooling	6
Low Ambient Operation	6

NOTE: Minimum condenser water flow based on 3 ft/sec to minimize condenser fouling. Flow rates below 3 ft/sec may require more frequent tube cleaning.

### Step 5 — Make Electrical Connections

All field wiring must conform with local code requirements. Control circuit is 115 volts on all 60-Hertz units. Control power is supplied from a separate source, thru a 15-amp fused disconnect.

Inside the control box, provisions are made to connect the ground wires which must be installed with each field power supply.

The 30HK,HL015 units are factory supplied with across-the-line start at all voltages and cannot be converted to part-winding start. The 30HK, HL020,025,030 units are factory supplied with part-winding start at 208/230 volts and across-the-line start at 460,575 volts.

Refer to Tables 4 and 5 for electrical data on individual compressors and complete units. Compressor usage is given in Tables 2 and 5.

### ELECTRICAL BOX, CONTROL SECTION

Inside this section are relays, high- and low-pressure cutouts, low water-temperature cutout, timer, terminal strips and a 3-step temperature controller. On the outside (control panel) are control circuit ON-OFF switch, partial load switch (DLS), compressor run light, safety trip lights and control circuit fuse. The control panel is hinged to provide easy access to the controls inside.

→ **Table 4 — Unit Voltage and Model Number\***

VOLTS	UNIT 30HK,HL
	015,020,025,030
208/230	5--
460	6--
575	1--

\*Complete number has 10 digits.  
Example: 30HK020530.

### UNBALANCED 3-PHASE SUPPLY VOLTAGE

Never operate a motor where a phase imbalance in supply voltage is greater than 2%. Use the following formula to determine the % voltage imbalance:

$$\% \text{ Voltage Imbalance} = 100 \times \frac{\text{max voltage deviation from average voltage}}{\text{average voltage}}$$

Example: Supply voltage is 240-3-60.

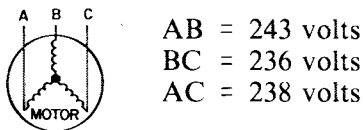

$$\begin{aligned} \text{Average Voltage} &= \frac{243 + 236 + 238}{3} \\ &= \frac{717}{3} = 239 \text{ volts} \end{aligned}$$

Determine maximum deviation from average voltage:

$$\begin{aligned} \text{(AB)} \quad 243 - 239 &= 4 \text{ volts} \\ \text{(BC)} \quad 239 - 236 &= 3 \text{ volts} \\ \text{(AC)} \quad 239 - 238 &= 1 \text{ volt} \end{aligned}$$

Maximum deviation is 4 volts.

Determine % voltage imbalance:

$$\% \text{ Voltage Imbalance} = 100 \times \frac{4}{239} = 1.7\%$$

This amount of phase imbalance is satisfactory as it is below the maximum allowable 2%.

**IMPORTANT:** If the supply voltage phase imbalance is more than 2%, contact your local electric utility company immediately.

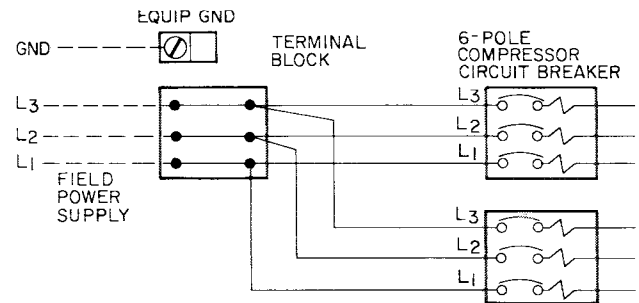

Control circuit power is from separate source, incoming wires are connected directly to terminals 1 and 2 on TB2.

EQUIP GND — Equipment Ground

**Fig. 3 — Wiring Schematic — Unit and Control Power Supply**

### ELECTRICAL BOX, POWER SECTION

The main electrical power supply is brought in thru the top of the electrical box, on the left-hand side (see Fig. 1). The hole accommodates up to a 3-in. conduit. Pressure-lug connections on terminal block are suitable for copper, copper-clad aluminum or aluminum wire, unless otherwise noted on a label near the terminal block.

The power section contains: main power terminal block, compressor circuit breaker with calibrated magnetic trip (for compressor motor overload and locked rotor protection), and compressor motor contactors. The panel over this section is secured with screws as a safety measure against casual entry for purposes other than service.

→ **Table 5 — Electrical Data; 3-Phase, 60-Hertz**

COMPLETE UNIT

VOLTS	Nameplate		208/230*		460		575		COMPRESSOR 06E USAGE‡
	Supply Range†		187-253		414-508		518-632		
UNIT 30		MKW	MCA	Max Fuse Amps	MCA	Max Fuse Amps	MCA	Max Fuse Amps	
HK	015	16.4	69	110	34	60	29	50	C537**
	020	21.8	79	125	36	60	34	60	2150
	025	29.0	103	175	50	90	45	80	7265
	030	31.0	115	200	50	90	49	80	7175
HL	015	19.1	80	125	38	60	30	50	C537**
	020	25.2	90	150	42	70	38	60	2250
	025	31.8	115	200	50	90	45	80	7265
	030	35.9	140	250	62	110	53	90	7275

INDIVIDUAL COMPRESSORS

UNIT 30		COMPRESSOR		208/230 V*			460 V			575 V		
		06‡	Kw	RLA	LRA	MTA	RLA	LRA	MTA	RLA	LRA	MTA
HK	015	C537**	16.4	55	266	77	27	120	37	23	96	31
	020	2150	21.8	63	283	88	29	142	40	27	98	37
	025	7265	29.0	82	446	114	40	223	56	36	164	50
	030	7175	31.0	92	446	128	40	223	56	39	164	54
HL	015	C537**	19.1	64	266	89	30	120	41	24	96	33
	020	2250	25.2	72	345	100	33	173	45	30	120	42
	025	7265	31.8	92	446	128	40	223	56	36	164	50
	030	7275	35.9	112	506	156	49	253	68	42	176	58

- KW** — Maximum Power Input (compressor)
- LRA** — Locked Rotor Amps
- MCA** — Minimum Circuit Amps (for wire sizing). Complies with National Electrical Code (NEC) Section 430-24.
- MKW** — Unit power input at operating conditions of 50F Leaving Chilled Water Temperature (44F Saturated Suction Temperature) and 120F (HK) or 145F (HL) Saturated Discharge Temperature.
- MTA** — Must Trip Amps (factory-installed circuit breaker)
- RLA** — Rated Load Amps

- \*Compressors in all models have extended voltage motor.
- †Units are suitable for use on electrical systems where voltage supplied to the unit terminals is not below or above the range limits shown.
- ‡Prefix: 2 = 1 electric unloader; C, 7 = 2 electric unloaders.
- \*\*30HK,HL015 models use 06D compressor instead of 06E compressors.

**START-UP AND SERVICE**

**WARNING:** Shut off all power to unit before proceeding with any service work.

**Initial Check**

Do not attempt to start the liquid chiller even momentarily until the following steps have been completed.

1. Check all auxiliary components such as chilled liquid circulating pump, cooling tower if used, air handling equipment, or other equipment to which chiller supplies liquid. Consult manufacturer's instructions.
2. Check safety thermostat. See Safety Thermostat.
3. Determine if there is a refrigerant charge in the system. Refer to Check Refrigerant Charge.
4. Backseat (open) compressor suction and discharge shutoff valves.
5. Open liquid line shutoff valves.
6. Open valves to capillaries of water-regulating valve (when used).

7. Fill chilled liquid circuit with clean water or other noncorrosive fluid to be cooled. Bleed all air out of high points of system.
8. Open supply valve (or fill cooling tower if used) for condenser cooling water.
9. Set temperature controller.
10. Check tightness of all electrical connections.
11. Be sure compressor is floating freely on the isolation springs. See Installation, Step 3.
12. Check compressor oil (should be visible in bull's-eye). Refer to Check Oil Charge.
13. Be sure crankcase of each compressor is warm (heaters should be on for 24 hours before starting compressors).

**Check Refrigerant Charge**

**IMPORTANT:** Do not open liquid valve or compressor discharge valve until there is a charge in remainder of system. A positive pressure will indicate a charge in system.

The 30HK units are shipped with a full refrigerant charge (see Table 2). However, if it is necessary to add refrigerant, operate the unit for some time at full capacity and then add charge until the sight glass is clear of bubbles. For maximum liquid subcooling, liquid level should be up to condenser liquid level test cock located on shell, near condenser end. This usually requires additional refrigerant charge beyond amount to clear sight glass.

30HL units (condenserless) are shipped with a holding charge only. After chiller assembly is completed in the field, system must be fully charged. While unit is running at full capacity, add refrigerant until sight glass is clear.

If there is no refrigerant vapor pressure in the system, the entire system must be leak tested. After repair of leaks, evacuate system before recharging. See Carrier Standard Service Techniques Manual, Chapter 1, Refrigerants, for leak testing, evacuation and charging procedures.

**CAUTION:** When adjusting refrigerant charge, circulate water thru the condenser and cooler at all times to prevent freezing. Freezing damage is considered abuse and may affect the Carrier warranty.

The liquid charging method is recommended for complete charging or when additional charge is required.

#### LIQUID CHARGING METHOD

**CAUTION:** Be careful not to overcharge system. Overcharging results in higher discharge pressure with higher cooling water consumption, possible compressor damage, and higher power consumption.

Charge thru 1/4-in. flare connection on liquid line shutoff valve. *Never charge liquid into low-pressure side of system.*

1. Frontseat (close) liquid line shutoff valve.
2. Connect a refrigerant cylinder loosely to charging valve connection. Purge charging line and tighten connections.
3. Open liquid line shutoff valve.
4. If system has been dehydrated and is under vacuum, break vacuum with refrigerant (gas charge). Build up system pressure to 58 psi for R-22 (32 F). Invert refrigerant cylinder so that liquid refrigerant will be charged.
5. a. For complete charge, see Charging in Carrier Standard Service Techniques Manual, Chapter 1, Refrigerants. Follow Charging By Weight procedure. (When charge is nearly full, complete process by observing sight glass for clear liquid flow.)  
b. For complete charge where refrigerant cylinder cannot be weighed, or for adding refrigerant, follow the procedure Charging By Sight Glass in manual.

6. To ensure maximum subcooler performance on 30HK units, check liquid level in condenser by means of test cock located on condenser shell near right end tube sheet. Liquid discharge from test cock indicates fully charged subcooler.

**Check Oil Charge** — All units are factory charged with oil. If oil is visible in sight glass, check unit for operating readiness as described in the section, Initial Check; then start compressor. Observe level and add oil, if required, to bring level in crankcase 1/8 to 3/8 of bull's-eye during steady operation. To add or remove oil, see Carrier Standard Service Techniques Manual, Chapter 1, Refrigerants.

→ *Use only Carrier-approved compressor oil:*  
Witco Chemical Co. . . . . Suniso 3GS  
Texaco, Inc. . . . . Capella WF-32

*Do not reuse oil that has been drained and do not use oil that has been exposed to atmosphere.*

#### TO ADD OIL

Close suction shutoff valve and pump down crankcase to 2 psig (low-pressure cutout must be bypassed with a jumper). Wait a few minutes and repeat as needed until pressure remains at 2 psig. Close discharge shutoff valve. Remove oil fill plug above bull's-eye, add oil thru plug hole and replace plug. Reopen suction and discharge valves. Run compressor for about 20 minutes and check oil level.

#### TO REMOVE OIL

Pump down compressor to 2 psig. Close suction and discharge valves. Loosen the 1/4-in. pipe plug in compressor base and allow oil to seep out past plug threads. *The crankcase will be under slight pressure. Be careful not to remove plug; the entire oil charge may be lost.* Small amounts of oil can be removed thru oil pump discharge connection while compressor is running.

#### START-UP

*Start-up should be performed only under supervision of experienced refrigeration mechanic. Be sure crankcase heaters have been energized for 24 hours.*

1. Open all system valves that may have been closed during or after charging.
2. Check air handling equipment, chilled water and condenser water pumps, and any other equipment connected to chiller.
3. Start unit by firmly pushing ON button.
4. Check all controls for proper operation. Refer to Check Unit Safety Devices.
5. Adjust water-regulating valve (if used) to most economical head pressure (based on relative cost of water and electricity). Head pressure is normally 200 to 230 psi for R-22.

6. Check leaving chilled water temperature to see that it remains well above freezing.
7. Recheck compressor oil level. See Check Oil Charge.

### Check Refrigerant Feed Components

#### THERMOSTATIC EXPANSION VALVE (TXV)

This valve controls refrigerant flow. Valve is activated by a temperature sensing bulb clamped to suction line. The valve is factory set to maintain a superheat of 8F to 10F. *Do not change setting unless absolutely necessary.*

#### FILTER DRIER

The 30HK,HL015 thru 030 units (single compressor) have sealed-type driers. When a drier must be changed, the entire drier must be replaced. The function of the filter drier is to maintain a clean, dry system. The moisture indicator (below) can indicate any need to change filter drier.

#### MOISTURE-LIQUID INDICATOR

The indicator is located immediately ahead of the TXV to provide a constant indication of refrigerant moisture content. It also provides a sight glass for refrigerant liquid. Clear flow of liquid refrigerant indicates sufficient charge in system. Bubbles indicate under-charged system or presence of noncondensables. Moisture in the system, measured in parts per million (ppm), will change color of indicator.

*Unit must be in operation at least 12 hours before moisture indicator will give an accurate reading. With unit running, indicating element must be in contact with liquid refrigerant to give true moisture indication.*

At first sign of moisture in the system, change the filter drier. The tables below indicate when the change is required.

30HK,HL015,020

COLOR	CONDITION
Green	Dry: moisture is below 45 ppm
Chartreuse	Caution: 45 ppm
Yellow	Wet: above 130 ppm

30HK,HL025,030

COLOR	CONDITION
Blue	Safe, dry
Light violet	First sign of moisture
Pink	Dangerous moisture level

#### LIQUID-LINE SERVICE VALVE

This valve provides a refrigerant charging port and, in combination with the compressor discharge service valve, allows the refrigerant to be pumped into the high side.

#### LIQUID-LINE SOLENOID VALVE (HL only)

The solenoid valve closes when its circuit is inoperative, either from capacity control or from any safety trip.

### PRESSURE RELIEF DEVICES

On HK units, a high-side pressure-relief valve is factory installed on the condenser. The valve is set to open at a maximum pressure of 385 psig (maximum design working pressure of the condenser).

→ For 30HL units, pressure relief device, designed to relieve at 450 psig, is field supplied and installed in the discharge line after the muffler according to ANSI.B9.1 code requirements.

Additional pressure relief valves, properly selected, must be field installed to protect field-installed high-side equipment as may be required by applicable codes.

A fusible plug is factory installed on the suction line for low-side protection. This plug will relieve on temperature rise to 170 F.

Most local codes require that a relief valve be vented directly to outdoors. *The vent line must not be smaller than the relief valve outlet (5/8-in. SAE).*

#### CHECK VALVE

A discharge-line check valve is supplied with each condenserless (HL) unit as standard equipment. This valve should be located downstream from, but close to, the hot gas muffler. The valve can be mounted in either horizontal or vertical position.

The valve prevents migration of refrigerant from condenser to compressor and cooler during off-cycle of compressor.

### Check Compressor Protection Devices

#### CIRCUIT BREAKER

The compressor is protected against an over-current condition by a manual-reset calibrated-trip circuit breaker.

**IMPORTANT:** Do not bypass connections or increase breaker size to correct trouble. Determine the cause and correct before resetting breaker.

### MOTOR OVERTEMPERATURE

#### THERMOSTAT

On size 015 units, a sensor embedded in motor windings protects against overtemperature.

On all other sizes, a sensor in the discharge side of the compressor reacts to excessively high discharge gas temperature and shuts off the compressor. A high discharge gas temperature indicates an overtemperature condition in motor windings.

#### CRANKCASE HEATER

The heater prevents absorption of liquid refrigerant by oil when compressor is not operating.

On size 015 units, the heater is secured by a clip; on all other sizes, it is held in place by a bracket.

**CAUTION:** The heater must be tight to prevent it from backing out of the crankcase. The heater will burn out if exposed to air for an extended time.



The electric heater is wired into the 115-volt control circuit thru normally closed contacts of control relay in such a way that it is energized only when compressor is not operating.

All heaters are 125 watts.

**CAUTION:** Never open any switch or disconnect that will de-energize crankcase heater unless unit is being serviced or will be shut down for a prolonged period. After such service or prolonged shutdown, energize crankcase heater for 24 hours before starting compressor.

#### TIME GUARD® CONTROL

This control protects compressor against short cycling (Switch A on four-function timer).

#### FOUR-FUNCTION TIMER

Refer to Fig. 4 — Timer Cycle. The functions are as follows:

Switch A (Contacts A-A1, A-A2) runs timer motor. This provides a minimum of 5-1/2 minutes after compressor stops before it can restart, to prevent short cycling (Time Guard control).

Switch B (Contacts B-B1, B-B2) provides 1-second time delay for part-winding start and also provides a lock-out function.

Switch D (Contacts D-D1) provides a 2-1/2 minute bypass of the low-pressure switch at start-up to prevent nuisance trips under cold-start conditions.

Switch E (Contacts E-E1) provides a 35-second bypass of the oil safety switch (OPS) at compressor start-up (when OPS is used). If sufficient oil pressure does not build up in this time, compressor stops.

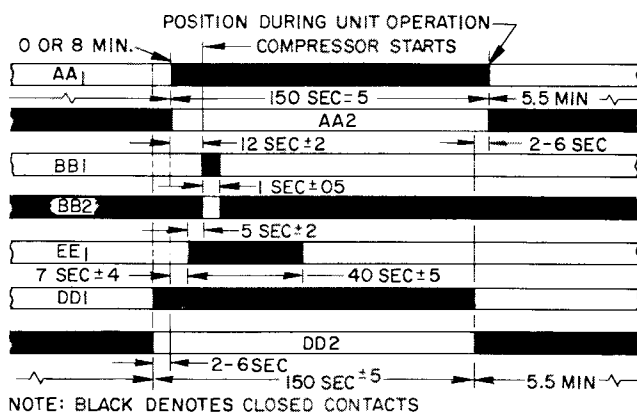

Fig. 4 — Timer Cycle

#### OIL PRESSURE SAFETY SWITCH (OPS)

This control is standard on 30HL (condenserless) units (020-030) and is available as an accessory for 30HK units (020-030). Refer to Fig. 5 for field wiring connections. It is not available for the 015 unit.

The pressure switch is factory set at the following pressures and should not be adjusted in the field.

SWITCH POSITION	PRESSURE SETTING
Close on rise	9 - 12 psi diff
Open on fall	4 - 6 psi diff

The oil pressure safety switch is wired in parallel with Switch E of the 4-function timer. This arrangement allows approximately 35 seconds for oil pressure to reach normal operating level after compressor starts. If the oil safety switch does not close within 35 seconds, the compressor shuts down.

To restart the compressor, the control circuit ON-OFF switch must be pressed to OFF and then to ON. The timer will start and after approximately 5-1/2 minutes compressor will start. If normal oil pressure is established within the next 35 seconds, the compressor continues to run. If, however, the oil pressure does not reach a safe level, the compressor stops at the end of the 35 seconds and locks out.

**CAUTION:** Do not attempt to restart the compressor for a second time until the problem has been determined and corrected.

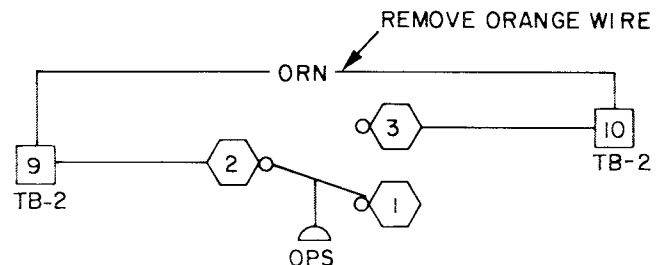

OPS — Oil Pressure Safety Switch  
TB — Terminal Board

Fig. 5 — Oil Pressure Safety Switch to Control Box Wiring Connections (020-030 Only)

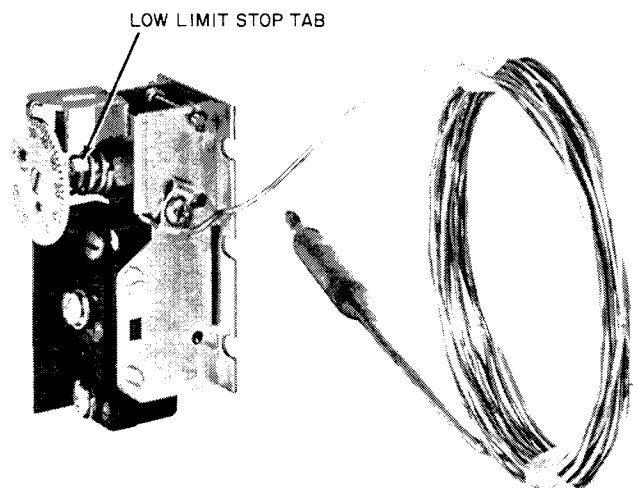

Fig. 6 — Safety Thermostat (No. HH22CC050 Shown)

## Check Unit Safety Devices

### SAFETY THERMOSTAT (Fig. 6)

The low water temperature cutout (LWTC) protects the unit against freeze-up due to operating malfunction. The sensing bulb is inserted into a well located in the *leaving* water nozzle. As installed, the standard control is factory set to open at  $36 \pm 2$  F, breaking the control circuit and locking out unit. The contacts remake at  $5 \pm 2$  F above cutout point, but the control circuit switch must be pressed to OFF and then to ON for unit restart. This action re-energizes the control circuit and starts the timer under Time Guard® control.

The thermostat cuts out in a range down to  $-30$  F, but to obtain this range, the low-limit stop tab on the underside of dial must be either cut or bent. *Make this adjustment only if necessary* (when cooling glycols or brines).

### HIGH-PRESSURE SWITCH (HPS)

The HPS settings are nonadjustable. Table 6 shows factory settings for this switch.

If HPS cuts out while unit is in normal operation (2-1/2 minutes or more after compressor start-up), compressor will stop and lock out. To restart compressor, the ON-OFF control circuit switch must be manually pressed to OFF and then to ON. The timer will start, and after approximately 5-1/2 minutes, the compressor will start under Time Guard control. If the pressure has not dropped to the HPS cut-in point (see Table 6), the compressor will stop again immediately and again lock out. *Do not attempt to restart until trouble is found and corrected.* Unless control circuit switch is pressed to OFF at this time, timer will continue to run.

**Table 6 — Pressure Switch Specifications**

UNIT 30		HK		HL	
PRESSURE RANGE (psig)	High	Fixed		Fixed	
	Low	10 to 90 Adjustable			
DIFFERENTIAL SETTING (psi)	High	96 $\pm$ 17 (Fixed)		103 $\pm$ 19 (Fixed)	
	Low	13 to 50 Adjustable			
		Cutout	Cut-in	Cutout	Cut-in
FACTORY SETTING (psig)	High	260 $\pm$ 10	—	335 $\pm$ 10	—
	Low	29 $\pm$ 4	44 $\pm$ 4	29 $\pm$ 4	44 $\pm$ 4

### LOW-PRESSURE SWITCH (LPS)

The LPS is bypassed for 2-1/2 minutes after compressor start on all start-ups. The LPS has an adjustable range from 10 to 90 psig and a differential of 13 to 50 psi. See Fig. 7. Table 6 shows factory settings for this switch.

If LPS cuts out while unit is in normal operation (any time after 2-1/2 minutes from compressor start-up) timer starts and runs for approximately 5-1/2 minutes. The compressor then starts, bypassing the LPS for 2-1/2 minutes under Time Guard control. If the LPS cut-in pressure is reached

within 2-1/2 minutes, compressor continues to run; if, on the other hand, the required pressure has not built up, compressor stops at end of 2-1/2 minutes and locks out.

Do not attempt to restart unit until trouble has been found and corrected. *The LPS contacts must be closed before compressor can be restarted after lockout.*

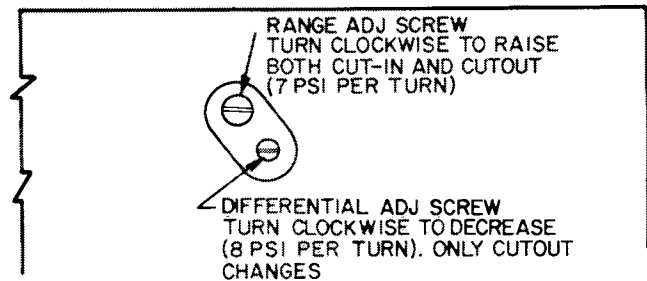

(RIGHT SIDE OF CONTROL BOX, VIEWED FROM TOP)

**Fig. 7 — Low-Pressure Switch (LPS) Adjustment**

## Check Capacity Control System

### DESCRIPTION

Capacity control is a system which loads and unloads compressor cylinders and starts and stops compressor to maintain load requirements. System includes a 3-step temperature controller and cylinder unloaders (see Table 2). Table 7 shows capacity control steps.

**Table 7 — Capacity Control Steps**

UNIT 30HK, 30HL	CONTROL STEPS	% CAP.	OPER CYL
015	1	33	2
	2	67	4
	3	100	6
020	1	35	2*
	2	50	2
	3	100	4
025, 030	1	33	2
	2	67	4
	3	100	6

\*Uses hot gas bypass.

### 3-STEP TEMPERATURE CONTROLLER

This controller consists of 3 load switches actuated by pressures developed in a temperature-sensing bulb located in return water line of chilled water system. The controller is factory set to control from *return* water temperature thru a cooling range of 10 F. Sequence switches are factory calibrated and sealed and should not require any field changes.

**IMPORTANT:** If a different return-water cooling range or *leaving-water* control is specified, or if brine below 10 F is to be used, controller must be changed. Consult local Carrier representative for proper control device.

The return water temperature at which the last step of capacity unloads is indicated by the leaving water temperature design set point on the adjustable dial (Fig. 8).

Example:

Design set point is at 44 F. On a reduction in load, the capacity of the unit will be reduced to zero when return water temperature drops to 44 F, and unit will cycle off.

**WARNING:** Any alteration of factory settings, except design set point, without Carrier authorization, may void the Carrier Warranty.

### DESIGN SET POINT ADJUSTMENT

When unit is ready for operation, insert small screwdriver in adjusting slot (Fig. 8) and rotate to turn dial (dial may also be turned by hand). Rotate until design set point for installation appears directly under pointer. Insert a thermometer in the *return* chilled water connection and allow unit to run thru a cycle. At instant the last step of capacity unloads (switch no. 1 opens), read temperature. If it is not same as dial reading, variation can be compensated by shifting control point slightly.

**CAUTION:** Do not force dial past stop. This can cause loss of control point and damage instrument.

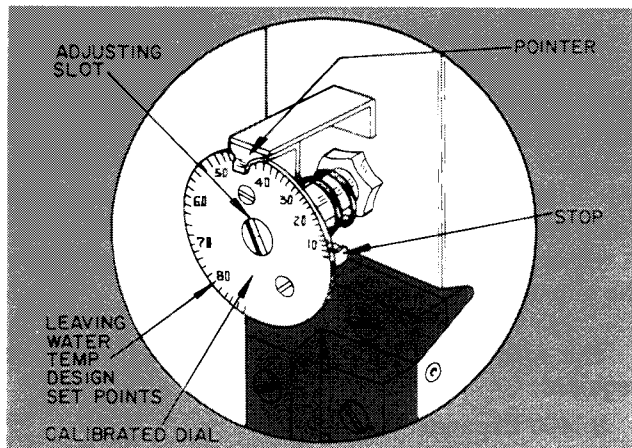

Fig. 8 — Set Point Adjustment

### CYLINDER UNLOADING SYSTEM

Each unloading device is the cylinder head suction cutoff type, which unloads 2 cylinders (one bank) when the control solenoid is energized. Load switches in the temperature controller energize and de-energize the cylinder unloaders.

## UNIT OPERATION

**Control Power** (115 volts) can be from a separate source, thru a 15-amp fused disconnect or can be taken from the main unit power source, thru a field-supplied transformer shown on wiring label.

**Control Sequence** — At initial start-up, assume all safety devices are satisfied and the chilled water temperature controller switches are all in position for maximum cooling capacity.

Close compressor circuit breaker and press control circuit ON-OFF switch to ON. The timer starts and, depending on position of timer the compressor starts in approximately 12 seconds to 8 minutes. At compressor start-up, D-D1 contacts (see Four-Function Timer and Fig. 4) are closed, bypassing low-pressure switch for 2-1/2 minutes. In addition, the E-E1 contacts are closed, bypassing the oil safety switch (if used) for approximately 35 seconds. Both these bypass functions protect against compressor continuing to run under conditions that could cause damage to the compressor. Barring any malfunction, when timer contacts A-A2 close, approximately 2-1/2 minutes after start-up, unit is in normal operation. The timer stops when A-A2 contacts close and holds in this position while the temperature controller regulates the cooling capacity by loading and unloading compressor cylinders, and by stopping and starting the compressor, under Time Guard® control, in response to load requirements.

**Unit Stoppage and Restart** — After each description of a possible cause for unit stoppage is a short description of the normal method of restart.

#### 1. CONTROL POWER INTERRUPTION (INCLUDES BLOWN FUSE).

After power is restored, or fuse replaced, restart is automatic thru normal timer cycle.

#### 2. CONTROL CIRCUIT ON-OFF SWITCH IS OPENED.

The timer motor starts automatically, runs for approximately 5-1/2 minutes, and then stops. To restart, press ON-OFF switch to ON. Compressor will start in approximately 12 seconds.

#### 3. CONTACTS OF ANY AUXILIARY INTERLOCK ARE OPEN.

After trouble has been corrected, restart is automatic thru the normal timer cycle.

#### 4. LOW WATER TEMPERATURE CUTOFF CONTACTS ARE OPEN.

Allow time for water temperature to rise 5 F; then press the control circuit ON-OFF switch to OFF, and back to ON. This restarts timer. Unit restarts automatically on the normal timer cycle.

#### 5. CONTROL CIRCUIT FUSE BLOWS.

Refer to Stoppage Cause No. 1 above for normal restart description.

## 6. ANY SAFETY DEVICE TRIPS.

If device is low-pressure switch, reset is automatic and unit restart is thru normal timer cycle. In the case of low, or lost, refrigerant charge, charge must be increased to normal level before restart.

If device is one of the following, high-pressure switch, overtemperature switch or oil pressure safety switch, press control circuit ON-OFF switch to OFF, then to ON. Restart occurs thru normal timer cycle.

If chilled water flow has stopped, locate and correct cause, restart water flow. Unit will restart automatically thru normal timer cycle.

**IMPORTANT:** If stoppage by a safety device repeats once, do not attempt another restart until cause is determined and corrected.

Refer also to Troubleshooting section for additional information on unit malfunctions.

## SERVICING COOLER

When cooler heads and partition plates are removed, tube sheets are exposed showing tube ends shown in Fig. 9.

**CAUTION:** Four tubes in the bundle are secured inside cooler at baffles and *cannot be removed*. These are identified on the tube sheets by a drill mark horizontally adjacent to each of the 4 tubes. If leakage occurs in any of these 4 tubes, plug tube as described under Tube Plugging.

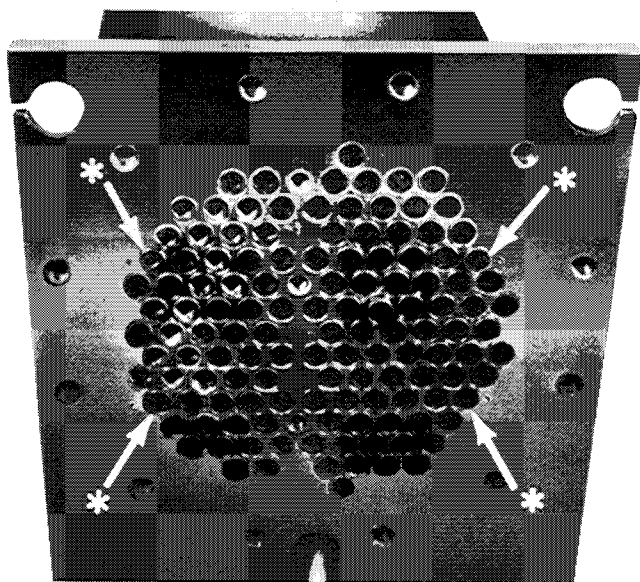

\*Four fixed tubes (cannot be removed) identified by adjacent drill points.

**Fig. 9 — Typical Tube Sheet**

**Tube Plugging** — Leaky tube(s) can be plugged until retubing can be done. The number of plugged tubes determines how soon cooler *must* be retubed. If several tubes require plugging, check with your local Carrier representative to find out how number and location will affect unit capacity.

Figure 10 shows an Elliott tube plug and a cross-sectional view of a plug in place. Table 8 lists the components for plugging.

**CAUTION:** Use extreme care when installing plugs to prevent damaging the tube sheet sections between holes.

Clean parts with Locquic "N" and apply a few drops of Loctite #75 to obtain a tight seal without using too much force to set pin.

Usually plugs can be removed by heating projecting end of pin to approximately 1000 F and chilling quickly with water. Apply heating flame to side of the pin to prevent overheating tube sheet.

**Table 8 — Plugs and Tubes**

UNIT 30HK,HL	015,020	025,030
<b>COMPONENTS FOR PLUGGING</b>	<b>PART NUMBER</b>	
<b>For Tubes</b>		
Brass Pin	853103-500*	
Brass Ring	853002-570*	
<b>For Holes without Tubes</b>		
Brass Pin	853103-1*	
Brass Ring	853002-631*	
Loctite	No. 75†	
Locquic	"N"†	

\*Order directly from Elliott Tube Co.  
Dayton, Ohio.

†Can be obtained locally.

**Retubing** (See Table 8) — When retubing is to be done, obtain service of qualified personnel experienced in boiler maintenance and repair. Most standard procedures can be followed when retubing the 10HA coolers. A 6% crush is recommended when rolling replacement tubes into the tube sheet. A 6% crush can be achieved by setting the torque on the gun at 48 to 50 in. lbs.

The following Elliott Co. tube rolling tools are required:

- B3400 Expander Assembly
- B3401 Cage
- B3405 Mandrel
- B3408 Rolls

Place one drop of Loctite No. 67541, or equivalent, on top of tube prior to rolling.

Tube information:

	in.	(mm)
• Tube sheet hole diameter .....	0.631	(16.03)
• Tube OD .....	0.625	(15.87)
• Tube ID after rolling.....	0.581	(14.76 to
(includes expansion due	to	14.94)
to clearance)	0.588	

NOTE: Tubes next to gasket webs must be flush with tube sheet (both ends).

### Tightening Cooler Head Bolts

#### GASKET PREPARATION

When reassembling, use new gaskets. Compressed asbestos, neoprene gaskets, Carrier Material Specification ZA00-24, are to be momentarily dipped in compressor break-in oil prior to assembly. Do not soak gaskets in oil as gasket deterioration results. Use dipped gaskets within 30 minutes to prevent deterioration.

#### → BOLT TORQUES

Apply the following torques during bolt tightening sequence described below:

1/2-in. diameter flange bolts..... 70 - 90 lb ft

#### → BOLT TIGHTENING SEQUENCE (Fig. 11)

The following is a recommended bolt tightening sequence:

Step 1 — Tighten moderately (without torquing) all the flange bolts in sequence shown.

Step 2 — Repeat Step 1, tightening bolts to specified torque.

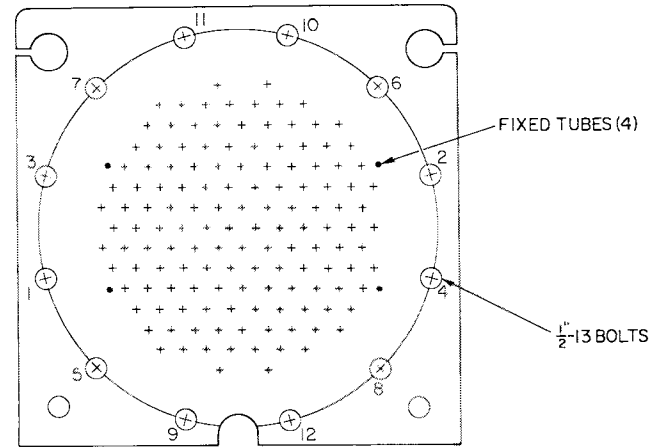

→ Fig. 11 — Tightening Sequence, Cooler Head Bolts

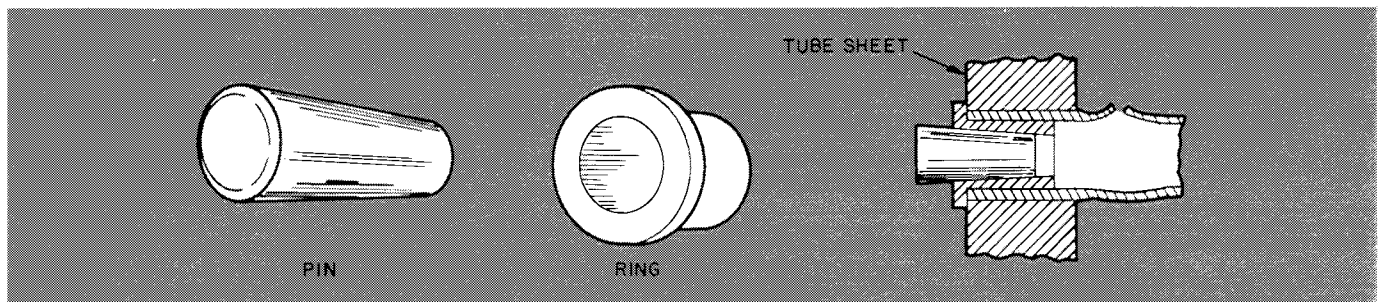

Fig. 10 — Elliott Tube Plug

## TROUBLESHOOTING GUIDE

SYMPTOMS	PROBABLE CAUSE	REMEDY
Compressor does not run	Power line open	Reset circuit breaker.
	Control circuit breaker tripped	Check control circuit for ground or short.
		Reset breaker.
	Safety tripped	Reset.
	Tripped power breaker	Check the controls. Find cause of trip and reset breaker.
	Condenser circulating pump not running	Power off — restart.
		Pump binding — free pump.
		Incorrect wiring — rewire.
		Pump motor burned out — replace.
	Loose terminal connection	Check connections.
	Improperly wired controls	Check wiring and rewire.
Low line voltage	Check line voltage — determine location of voltage drop and remedy deficiency.	
Compressor motor defective	Check motor winding for open or short. Replace compressor, if necessary.	
Seized compressor	Replace compressor.	
Compressor cycles on low-pressure control	Low-pressure control erratic in action	Raise differential setting.
		Check capillary for pinches.
		Replace control.
	Compressor suction valve leaking	Replace valve plate.
	Compressor suction shutoff valve partially closed	Open valve.
	Low refrigerant charge	Add refrigerant.
Plugged compressor suction strainer	Clean strainer or replace.	
Compressor loses oil	Leak in system	Repair leak.
	Mechanical damage (blown piston or broken discharge valve)	Repair damage or replace compressor.
	Oil trapped in line	Check piping for oil traps.
	Crankcase heaters not energized during shutdown	Check wiring and crankcase heater relay. Replace heater if necessary.
Frosted suction line	Expansion valve admitting excess refrigerant	Adjust expansion valve. Replace valve if defective.
Compressor cycles on high-pressure control	High-pressure control erratic in action	Check capillary tube for pinches.
		Set control as required.
	Compressor discharge valve partially closed	Open valve, or replace if defective.
	Air in system	Purge.
	Condenser scaled	Clean condenser.
Condenser water pump or fans not operating	Start pump — repair or replace if defective.	
Unit operates long or continuously	Low refrigerant charge	Add refrigerant.
	Control contacts fused	Replace control.
	Air in system	Purge.
	Partially plugged or plugged expansion valve or strainer	Clean or replace.
	Defective insulation	Replace or repair.
	Service load too high	Keep doors and windows closed.
Inefficient compressor	Check valves, replace if necessary.	

## TROUBLESHOOTING GUIDE (cont)

SYMPTOM	PROBABLE CAUSE	REMEDY
System noises	Piping vibration	Support piping as required.
		Check for loose pipe connectors.
	Expansion valve hissing	Add refrigerant.
		Check for plugged liquid line strainer.
	Compressor noisy	Check valve plates for valve noise.
		Replace compressor (worn bearings).
Check for loose compressor holddown bolts.		
Freeze-up	Improper charging	Make sure that a full quantity of water is flowing thru the cooler while charging and that suction pressure in cooler is equal to or greater than that corresponding to 32 F (58 psig for Refrigerant 22).
	Improperly set safety thermostat	Check safety thermostat for proper setting at beginning of each season.
	Operating with safety thermostat bypassed	If thermostat was bypassed for checking, be sure it is back in the circuit before starting the unit.
	Improper circulation of chilled water	Use ample size cleanable strainer in the chilled water circuit. Make sure strainer is clean. It may sometimes be necessary to chemically treat the water to prevent formation of deposits.
	System not drained for winter shutdown	Remove drain plugs at end of cooling season. Blow out any residual water. Instead of draining, a suitable antifreeze may be added to the water. <i>Damage to the chiller due to freezing is considered abuse and may affect the warranty.</i>
Hot liquid line	Shortage of refrigerant due to leak	Repair leak and recharge.
Frosted liquid line	Restricted filter drier	Remove restriction or replace filter drier core.
→ Compressor will not unload	Burned-out coil	Replace coil.
	Defective capacity control valve	Replace valve.
	Miswired solenoid	Rewire correctly.
	Weak, broken or wrong valve body spring	Replace spring.
→ Compressor will not load	Miswired solenoid	Rewire correctly.
	Defective capacity control valve	Replace valve.
	Plugged strainer (high side)	Clean or replace strainer.
	Stuck or damaged unloader piston or piston rings.	Clean or replace necessary parts.

Manufacturer reserves the right to discontinue, or change at any time, specifications or designs without notice and without incurring obligations.

**Book** | 2  
**Tab** | 5c

Form 30HK,HL-10SI Supersedes 30HK,HL-8SI Printed in U.S.A. 1090 3-83 PC111 Catalog No. 533-064

Download from [Www.Somanuals.com](http://Www.Somanuals.com). All Manuals Search And Download.



## Free Manuals Download Website

<http://myh66.com>

<http://usermanuals.us>

<http://www.somanuals.com>

<http://www.4manuals.cc>

<http://www.manual-lib.com>

<http://www.404manual.com>

<http://www.luxmanual.com>

<http://aubethermostatmanual.com>

Golf course search by state

<http://golfingnear.com>

Email search by domain

<http://emailbydomain.com>

Auto manuals search

<http://auto.somanuals.com>

TV manuals search

<http://tv.somanuals.com>