



Operator's manual

FS 1000 E



Please read the Operator's manual carefully and make sure you understand the instructions before using the machine.

English

Compliance with EU directives

Husqvarna Construction Products Sweden AB, Box 2098, SE-550 02 Jönköping, Sweden, tel: +46 (0)36-570 60 00, hereby certifies that its FS-1000 floor saw, having serial numbers 01001 onwards, is manufactured in compliance with the Council's machines directive 98/37/EG, low-voltage directive 73/23/EEG and EMC directive 89/336/EEG, including amendments, and that the following standards were used for guidance: EN 55 014-1, EN 55 014-2, EN 61 000-3-2, EN 50 144-1.

Jönköping 1 February 2001



Christer Carlberg

CEO

Contents

General instructions	4
Description and purpose	4
Safety precautions	5
Rating plate, warning signs and their meanings	5
Preparations before starting	5
Starting and operating	6
Maintenance	7
Fitting and replacing diamond blades	8
Lifting and transport	9
Troubleshooting	9
Technical specifications. Noise and vibration measurement ..	10
Parts list	11
Exploded diagram	13

General instructions

The FS 1000 EM floor saw is a professional machine designed for cutting reinforced concrete, asphalt and stone.

This machine may only be used by those who have carefully read this instruction manual and follow its instructions.

If you are unsure about any point please consult the supplier before starting to use the machine.

You must not modify the saw in any way without obtaining written approval from Husqvarna Construction Products Sweden AB. Modifications that are not approved could lead to serious or fatal injury to yourself or others. Husqvarna Construction Products Sweden AB does not accept any liability if the machine is used in any way or for any purpose that does not comply with these instructions.

1. Description and purpose

The FS 1000 EM electric floor saw is designed for cutting reinforced concrete, asphalt and other stone material in the building industry.

The saw has a full-width blade shaft, as shown in figure 1.1.2. This permits a diamond blade to be fitted on either the right or left side of the machine to allow cutting into corners from either side. The blade guard can be divided as shown in figure 1.1.5.

The floor saw is equipped with a water-cooling system, as shown in figure 1.2.2. to ensure effective cooling of the diamond blade and prevent dust formation.

The FS 1000 EM floor saw has the following controls:

- Height adjustment wheel as shown in figure 1.1.1.
- Blade shaft as shown in figure 1.1.2.
- Alignment guide for cutting a straight line as shown in figure 1.1.4.
- Adjuster screw for the above, as shown in figure 1.1.3.
- Blade guard as shown in figure 1.1.5.
- Control panel with switch, phase inverter and emergency stop as shown in figure 1.1.8.
- Power socket as shown in figure 1.2.1.
- Water-cooling nozzle as shown in figure 1.2.2.
- Guard for exposed drive shaft as shown in figure 1.2.3.
- Parking brake as shown in 1.2.4.

Figure 1.1

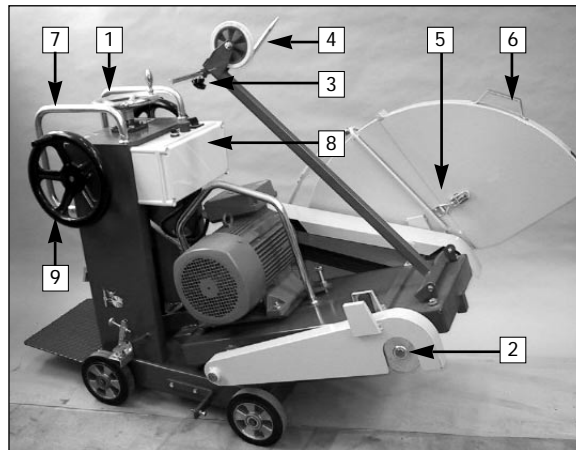

- 1.1.1. Height adjustment wheel.
- 1.1.2. Pulley shaft.
- 1.1.3. Adjuster screw for alignment guide.
- 1.1.4. Alignment guide.
- 1.1.5. Two-piece blade guard.
- 1.1.6. Lifting handle for blade guard.
- 1.1.7. Guide handle.
- 1.1.8. Control panel with switch, phase inverter and emergency stop.
- 1.1.9. Feed knobs.

Figure 1.2

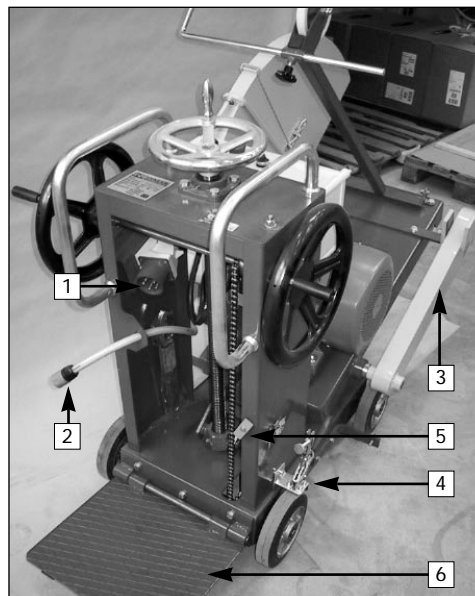

- 1.2.1. Power socket.
- 1.2.2. Water-cooling coupling.
- 1.2.3. Guard for exposed pulley shaft.
- 1.2.4. Parking brake.
- 1.2.5. Catch for base plate.
- 1.2.6. Base plate.

2. Safety precautions

You must follow the safety precautions before starting the machine. If the user does not follow these precautions then neither Husqvarna Construction Products Sweden AB nor its representative can accept any liability, whether direct or indirect.

The machine must not be used by any authorised person unless supervised by an authorised and experienced operator.





WARNING! Make sure you have read and understood the instructions in this manual before connecting the machine to the electrical supply.

- Check that the electrical connections are secure and that the power cable and plug comply with the specifications. See section 9 Technical specifications.
- Make sure that no-one comes closer than 4 metres to the front or side of the floor saw during operation.
- Check that the blade guard and blade flange guard are fitted correctly.
- The emergency stop must not be deactivated during start-up or operation.
- Before you start cutting, plan your work and clearly mark out the area you intend to cut so that you can carry out the work without risk of injury or damage to the machine. See figure 3.1.
- Check the building drawings to make sure there is no concealed wiring or plumbing in the area where you are cutting.
- Before you start cutting, make sure that any wiring in your working area is not carrying current.
- Before you start cutting, make sure that any plumbing in your working area has been shut off or disconnected.
- You must use the specified protective equipment and should wear protective clothing. See following page. Do not wear loose-fitting clothes that could catch on the machine or its moving parts.
- Anyone who has to remain nearby during cutting must wear hearing protection.
- Do not tilt, twist or carry the floor saw when the blade is turning.

2.1. Warning signs and their locations

The machine rating plate is located on the right side of the frame, as shown below.

Machine model: FS 1000 EM
Motor rating: 11 kW
Max. drive shaft rpm: 965 rpm
Max. blade diameter: 1000 mm
Max. peripheral blade speed: 63 m/s
Weight: (excl. blade) 285 kg
Year of manufacture:
Manufacturer: Husqvarna Construction Products Sweden AB

Warning signs and their locations	
The following decals on top of the frame explain that: you should read and follow the instruction manual before operating the floor saw you should wear safety equipment.	
	
CE	
The emergency stop is labelled	The control panel is labelled
NÖDSTOPP	
A decal on top of the blade guard shows the direction of rotation of the blade.	
Protective equipment	
The following protective equipment must be used when working with the floor saw.	
Helmet, hearing protection and eye protection	You must wear safety shoes
	

3. Preparations before starting

NOTE! Follow the safety precautions.

Do not fit a blade without first checking the direction of rotation of the drive shaft.

Plan your work and mark out the area to be cut.

- Check that the power cable and polarity match the specifications. See section 9 Technical specifications.
- Check that the water-cooling coupling matches the specifications. See section 9 Technical specifications.

- Set up a barrier or signs around the working area to prevent any unauthorised personnel from being injured or disturbing the operator while working.
- Check the belt tension as described in section 5.3. Adjust if necessary using the belt tensioning screw. Turning clockwise tightens the belts.
- Before you start cutting, plan your work and clearly mark out the area you intend to cut so that you can carry out the work without risk of injury or damage to the machine. See figure 3.1.
- To avoid interruptions and inconvenience during cutting, plan your work so that you fit the blade on the most suitable side of the saw right from the start.
- Check that you have the right diamond blade for the FS 1000 EM and the material you intend to cut. See section 9 Technical specifications.
- Check the direction of rotation before fitting the blade. Raise the blade guard on the side where you want to fit the blade. Secure the blade guard with the retaining strap. Connect the power cable and press the switch to start the machine. Check that the blade flange rotates in the direction shown by the arrow on the blade guard. If the flange rotates in the wrong direction, turn off the switch to stop the machine, then unplug the power cable from the machine. Change the setting of the phase inverter on the control panel. Stop the machine as described above and recheck.
- Check that the blade is not worn; each of the diamond segments must project at least 1 mm. They must also be wider than the body of the blade. See figure 6.3.
- Check that none of the diamond segments is damaged.
- Fit the blade so that the arrow on the body of the blade matches the direction of rotation of the shaft. Tighten the blade flange using the pin spanner supplied, while using the other spanner to prevent the blade shaft from turning. See the instructions in section 6, Fitting and replacing diamond blades.
- Lower the blade guard over the blade.
- Check that the blade is straight by turning the blade by hand and measuring the gap between the blade and the blade guard. If the blade is misaligned or uneven it must be replaced.
- Check that both the blade guard and the blade flange guard are correctly fitted, then lower them.
- Make sure the emergency stop is not deactivated. The emergency stop must not be deactivated during operation.
- Before starting the floor saw, raise the blade so that it rotates without touching the surface.

- Connect the power cable to the power socket.
- Connect the water-cooling hose to the coupling that runs from the blade guard.
- Check that the water supply is adequate and that the nozzle is not blocked.
- Make sure that the power cable and water-cooling hose from the floor saw will not get trapped underneath or in front of the machine when you start up or during cutting.
- Use the safety equipment specified in the safety precautions on page 5.

Figure 3.1.

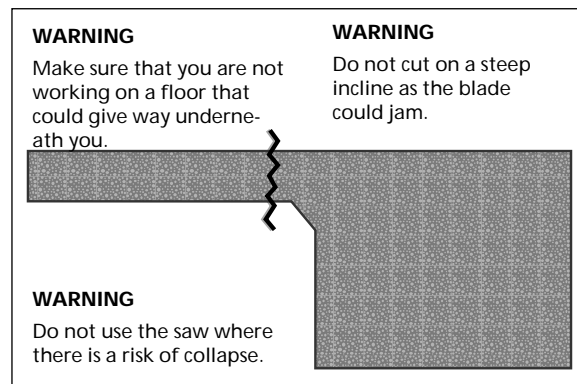

4. Starting and operating

Before starting and operating the saw follow the steps in section 3.

- Lower the alignment guide and adjust it so that the tip of the guide and the saw blade are in line.
- Clear away any objects from the path of the machine that could damage the machine or the surroundings.
- Check that there are no unauthorised people inside the working area, i.e. 4 metres in front of and to the side of the machine.
- Make sure that anyone who has to remain nearby is wearing hearing protection.
- Release the parking brake.
- Line up the floor saw with the cutting line you have marked on the floor.
- Check that the saw blade rotates freely.
- Check your safety equipment and any protective clothing you are wearing.
- Apply the parking brake.

- Lower the base plate by raising the safety catch.
- Turn on the cooling water to provide adequate cooling and prevent dust formation.
- Release the parking brake, while holding the guide handle on the machine with your other hand. (CAUTION! Do not hold the feed knob if you do not have full control over the machine.) NOTE! Do not stand in front of the machine.
- Turn the height adjustment wheel clockwise to lower the blade to a depth that is suitable for the material you are cutting, but no less than 20 mm.
- Cut a guide slot at this depth, moving steadily along your marked line. When you have completed the guide slot, turn the wheel to raise the blade, turn off the cooling water and stop the saw by pressing the red switch. Drag the machine back to the starting point.
- Realign the floor saw with the guide slot with the aid of the alignment guide, then start the machine as described above.
- Lower the saw blade to a suitable depth. The right cutting depth depends on the composition of the floor and the cutting speed. Generally, if the floor saw tries to climb up out of the slot then the cutting depth is too deep and/or the cutting speed is too high. The floor saw must not be advanced so fast that the blade tries to climb out of the slot. Adjust the cutting depth.
- Advance the machine smoothly and methodically, making sure that the alignment guide always follows the guide slot.

5. Maintenance

NOTE! Warning! Always disconnect the power cables before carrying out any maintenance, repairs or servicing.

- Clean the machine after completing a series of cuts. Note! Avoid spraying water at the electric motor and wiring.
- Lubricate the blade shaft bearing at the end of each day's use. During intensive cutting the blade shaft must be lubricated several times a day. Always use high quality water-resistant grease.
- Lubricate all other grease points at least once a week, or more often if necessary. See figure 5.1.1-4. Grease the wheel bearings if necessary. See figure 5.1.5.
- The safety devices are provided for your safety, so it is extremely important that you check all safety equipment regularly. If you discover a fault, contact your supplier. NOTE! Do not start the saw if you know that any of the machine's safety devices is faulty.

- Keep the machine's drive belts free of oil, dirt and dust. Check the belt tension regularly as described below. If the belts require tensioning, use the adjuster screw in front of the drive motor. Turn this clockwise to tighten the belts. See figures 5.2.2 and 5.3.
- Check the condition of the diamond blade regularly to make sure it is not damaged or worn down. Replace the blade when the segments are worn down or have become narrower than the body of the blade.
- Check that the water supply is working correctly. If not, clean the nozzle. See figure 5.2.1.
- Regularly check that electrical wiring and couplings are in good condition and that all screws are tight.

Figure 5.1

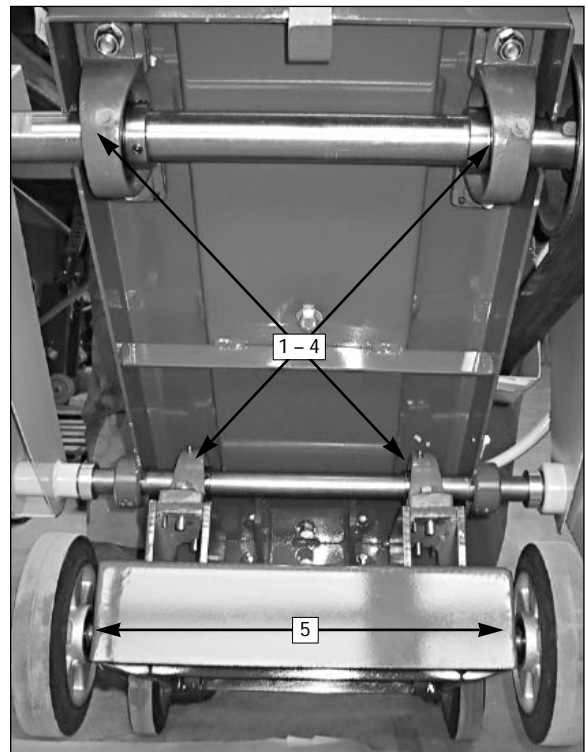

5.1.1-4. bearing housing grease points.

5.1.5. wheel bearings.

Figure 5.2

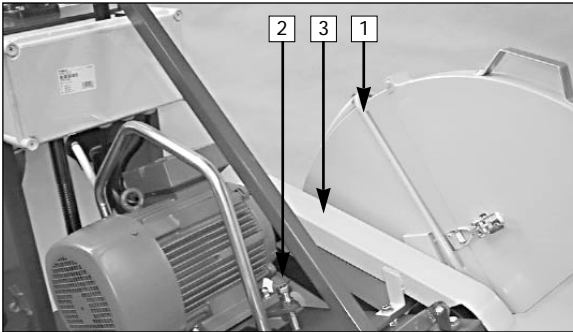

- 5.2.1. Water pipe for cooling blade
- 5.2.2. Belt tension adjuster screw.
- 5.2.3. Belt guard

Figure 5.3

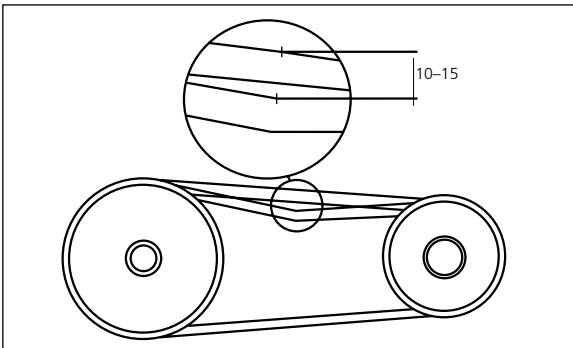

5.3. Sketch of drive belt arrangement.

Figure 5.4

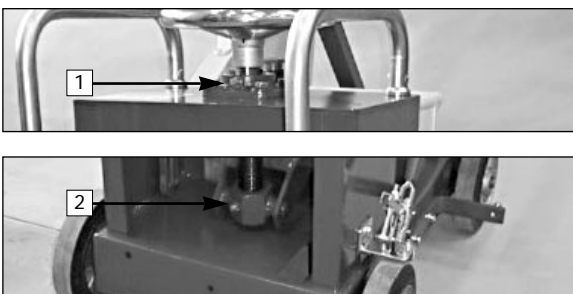

5.4.1-2 Grease points for height adjustment screw

6. Fitting and replacing diamond blades

WARNING! Before attempting to fix a fault you must make sure that the power cables are disconnected to prevent the machine from starting up while you are working.

- Raise the blade guard and secure it with the retaining strap.
- Clean the blade flanges and the blade shaft.

- Fit the blade. **NOTE!** Direction of rotation. See arrow on body of blade.
- Use the smaller of the two spanners supplied to prevent the blade shaft from turning, and use the larger spanner to undo or tighten the blade flange nut. See figure 6.1.
- Lower the blade guard.

Figure 6.1

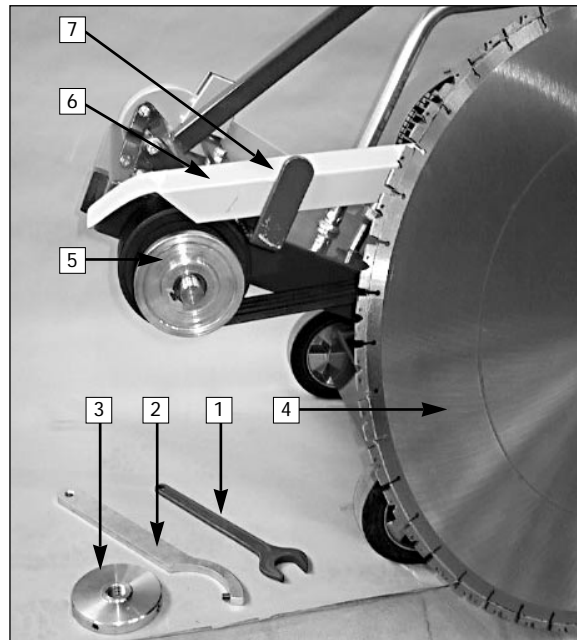

- 6.1.1. Spanner 36 mm.
- 6.1.2. Pin spanner.
- 6.1.3. Outer blade flange.
- 6.1.4. Diamond blade.
- 6.1.5. Inner blade flange (on pulley shaft).
- 6.1.6. Belt guard.
- 6.1.7. Support for blade guard.

Figure 6.3

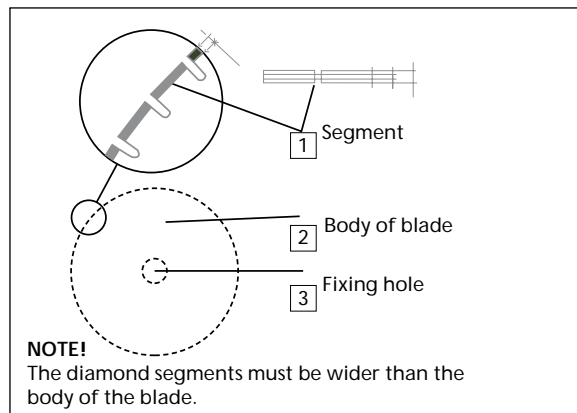

7. Lifting and transporting the floor saw

The FS 1000 EM floor saw has a lifting eye, which must be used when lifting the machine. Don't lift using any other parts, as this could cause damage to the machine and personal injury. If using a lifting strap, attach it to the lifting eye so that the machine cannot tip over during lifting. See figure 7.1. When transporting the floor saw, apply the parking brake and use anchor straps or the like to prevent it from moving about. See figure 7.3.

Figure 7.1

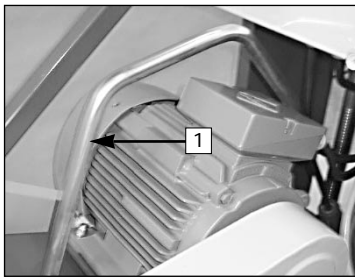
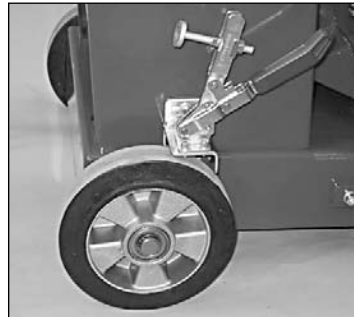
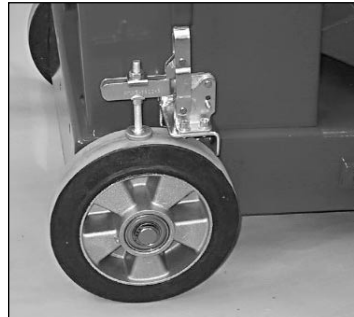

Figure 7.2



7.2. Parking brake off



7.3. Parking brake on

8. Troubleshooting

WARNING! Before attempting to fix a fault you must make sure that the power cables are disconnected to prevent the machine from starting up while you are working.

If there is a fault with the machine check first whether it matches any of the faults described in the troubleshooting chart below.

If you cannot localise the fault and it does not match any of the faults described in the troubleshooting chart you should contact your supplier for additional information.

FAULT	CAUSE	REMEDY
Blade turns wrong way.	Phases from power cable are inverted.	Change polarity using phase inverter.
Drive belt is slipping.	Belt is too slack. Drive belt is worn. Drive belt is oily.	Adjust belt tension. Replace the drive belt. Clean the drive belt.
Motor cuts out.	Cutting depth too large. Cutting speed too high. Diamond segments are worn. Blade gets jammed.	Reduce cutting depth. Advance more slowly. Replace diamond blade. Support floor from below using props or a jack.
No cooling water.	Nozzles are blocked. Water pressure too low.	Clean nozzles. Increase water pressure.
Blade gets jammed.	Blade is worn. Blade gets jammed.	Replace blade. Support floor from below using props or a jack.
Motor does not start.	Electrical fault. Emergency stop activated.	Contact your electrician. Determine cause. When fault is fixed, pull up emergency stop.

NOTE! Do not start the machine before rectifying the cause of the fault.

Technical specifications

The table below gives the technical specifications for the floor saw. It is extremely important that you check these before:

- Choosing a floor saw.
- Choosing and fitting a diamond blade.
- Connecting to the mains supply.
- Choosing a power cable.
- Choosing the cutting depth.
- Transporting the machine.

If you are unsure about the meaning of the technical specifications or ordering spare parts, please contact your supplier.

FS 1000 EM ART. NO. 50040		
Motor rating	kw	11
Voltage and type of supply	V/phase/Hz 220/3/50	400/3/50 or
Power cable	REVE	5x6
Polarity	Europa plug	32 Amp.
Phase inverter		separate knob
Drive shaft speed	rpm	965
Max. peripheral speed.	m/s	63
Max. diamond blade diameter	mm	1000
Parking brake		yes
Base plate equipment		standard
Chain drive equipment		standard
Max. Cutting depth	mm	420
Length approx.	mm	1750
Width approx.	mm	780
Height approx.	mm	1120
Weight (excl. blade) approx.	kg	275
Noise	noise power Lw rel. pw according to ISO 744 dB(A)	<101.7
Noise	noise pressure Lp rel. 0µPa at ear during operation B(A)	<84.8
Vibration	according to ISO 7505	0.8 m/s ² (H/A)

Pos. no.	Part No.	Quantity	Description
1	501351301	1	Frame
2	531072098	2	Wheel axle
3	531072193	4	Wheel FS800E & FS1000E
4	531072152	8	Slow fuse Sga 20
5	531072099	4	Cover sleeve
6	501353701	1	Angle
7	531072155	1	Screw M8x40 M6S 8.8 FZB
8	531072144	1	Nut M8 M6M GR8 FZB
9	531072153	1	Screw M8x25 M6S 8.8 FZB
10	531072203	2	Bearing UCP 204
11	531072133	4	Washer SRB 12.5 FZB
12	531072161	4	Screw M12x40 M6S 8.8 FZB
13	531072164	4	Screw M12x60 M6S 8.8 FZB
14	531072133	4	Washer SRB 12.5 FZB
15	531072205	2	Bearing UCP 205
16	531072101	2	Guide handle
17	531072159	4	Screw M12x30 M6S 8.8 FZB
18	531072102	1	Height adjustment screw
19	531072202	1	Bearing UCP 205
20	531072160	4	Screw M12x35 M6S 8.8 FZB
21	531072133	4	Washer SRB 12.5 FZB
22	531072146	4	Nut M12 M6M GR8 FZB
23	531072103	1	Spacer
24	531072142	2	Locking screw M8x10 MSK PGSS
25	531072149	1	Tube 6x45 CP
26	531072104	1	Height adjustment wheel
27	531072105	1	Pin spanner
28	531072192	1	Spanner 41 mm FS800E & FS1000E
29	531072048	1	Pulley shaft 675 mm
30	531072106	1	Shaft 30x745
31	531072142	2	Locking screw M8x10 MSK PGSS
32	531072107	1	Sleeve
33	501352101	1	Shaft guard
34	501356501	1	Cutting block
35	501353801	1	Bracket
36	531072159	2	Screw M12x30 M6S 8.8 FZB
37	531072109	1	Shaft 235x20
38	501352201	1	Motor block
39	531072176	1	Electric motor 11 kW
40	531072052	1	Lifting eye
41	531072146	4	Nut M12 M6M GR8 FZB
42	531072135	4	Spring washer FBB 12.2
43	531072133	4	Washer SRB 12.5 FZB

Pos. no.	Part No.	Quantity	Description
44	531072162	4	Screw M12x45 M6S 8.8 FZB
45	531072165	1	Screw M16x110 M6S 8.8 FZB
46	531072147	1	Nut M16 M6M GR8 FZB
47	531072191	7	Drive belt A61
48	531072053	1	Motor pulley
49	501352301	1	Belt guard
50	531072154	1	Screw M8x30 M6S 8.8 FZB
51	501352401	1	Angle bracket
52	531072164	4	Screw M12x60 M6S 8.8 FZB
53	531072133	4	Washer SRB 12.5 FZB
54	501353901	2	Angle
55	531072133	4	Washer SRB 12.5 FZB
56	531072146	4	Nut M12 M6M GR8 FZB
57	531072206	2	Bearing UCF 209
58	531072056	1	Shaft pulley
59	531072140	2	Locking screw M6x10 MSK PGSS
60	531072057	1	Wedge 90x40
61	531072058	2	Wedge 32x12
62	531072111	1	Outer blade flange, left-hand thread
63	531072059	2	Inner blade flange
64	531072112	1	Outer blade flange, right-hand thread
65	501352501	1	Blade guard, lower half
66	531072061	2	Brush
67	531072113	1	Sleeve
68	501352601	1	Front blade guard
69	501352701	1	Rear blade guard
70	531072199	1	Cooling hose 1/2" 1.3 m FS1000E
71	531072114	1	Catch
72	501352801	1	Support for alignment guide
73	531072153	2	Screw M8x25 M6S 8.8 FZB
74	531072131	2	Washer SRB 9 FZB
75	531072144	2	Nut M8 M6M GR8 FZB
76	531072115	1	Alignment guide
77	531072116	1	Locking screw spec.
78	531072158	1	Screw M10x60 M6S 8.8 FZB
79	531072195	1	Wheel for alignment guide
80	531072132	1	Washer SRB 11FZB
81	531072139	1	Locking nut M10 nylon
82	531072180	1	Socket 32 Amp
83	531072183	1	Automatic fuse
84	531072169	2	Relay FS1000E
85	531072185	1	Phase inverter FS1000E
86	531072178	1	Two-position switch FS1000E

Pos. no.	Part No.	Quantity	Description
87	531072186	1	Emergency stop FS1000E
88	531072179	1	Terminal box FS1000E
89	501354001	1	Base plate mounting
90	501354101	1	Base plate
91	531072121	1	Base plate shaft
92	531072156	3	Screw M10x30 M6S 8.8 FZB
93	531072132	3	Washer SRB 11FZB
94	531072138	1	Allen screw M8x40 MC6 S8.8 FZB
95	531072144	1	Nut M8 M6M GR8 FZB
96	531072122	1	Base plate catch
97	531072197	1	Chain 3/16" FS800 & FS1000E
98	531072150	1	Tube 6x50 CP
99	531072123	1	Toothed belt 3/16" Z15
100	531072124	1	Control wheel shaft
101	531072200	2	Bearing FL002
102	531072151	2	Tube 6x30 CP
103	531072125	1	Control wheel
104	531072144	2	Nut M8 M6M GR8 FZB
105	531072126	2	Knob
106	531072155	2	Screw M8x40 M6S 8.8 FZB
107	531072137	4	Allen screw M6x20 MC6 S8.8 FZB
108	531072127	2	Chain tensioner
109	531072132	2	Washer SRB 11 FZB
110	531072139	2	Locking nut M10 nylon
111	531072130	2	Washer SRB 7 FZB
112	531072143	2	Nut M6 M6M GR8 FZB
113	531072128	1	Drive shaft
114	531072129	1	Toothed belt 3/16" Z19
115	531072090	1	Pulley shaft assembly
116	501383501	1	Alignment guide assembly
117	531072117	1	Height adjustment screw assembly
118	531072182	1	Control panel assembly FS1000E
119	531072118	1	Parking brake
120	531072136	4	Allen screw M6x12 MC6 S8.8 FZB
121	531072152	2	Slow fuse Sga 20
122	531072161	2	Screw M12x40 M6S 8.8 FZB

Part No.	Quantity	Description
Parts no longer stocked up to serial no. 9405		
531072093	1	Pulley shaft earlier version
531072094	1	Pulley shaft assembly earlier version
52G37207	4	Older version of wheel
531072092	2	Older version of wheel axle
531072208	2	Rear wheel for drive
52G0708N	2	Chain 3/16" DFS-3EM for feed
531072209	1	Drive shaft
531072203	2	Bearing UCP 204 for drive
Accessories		
531072095	1	Flush cutting flange FS1000E
504006201	1	Flush cutting guard FS1000E

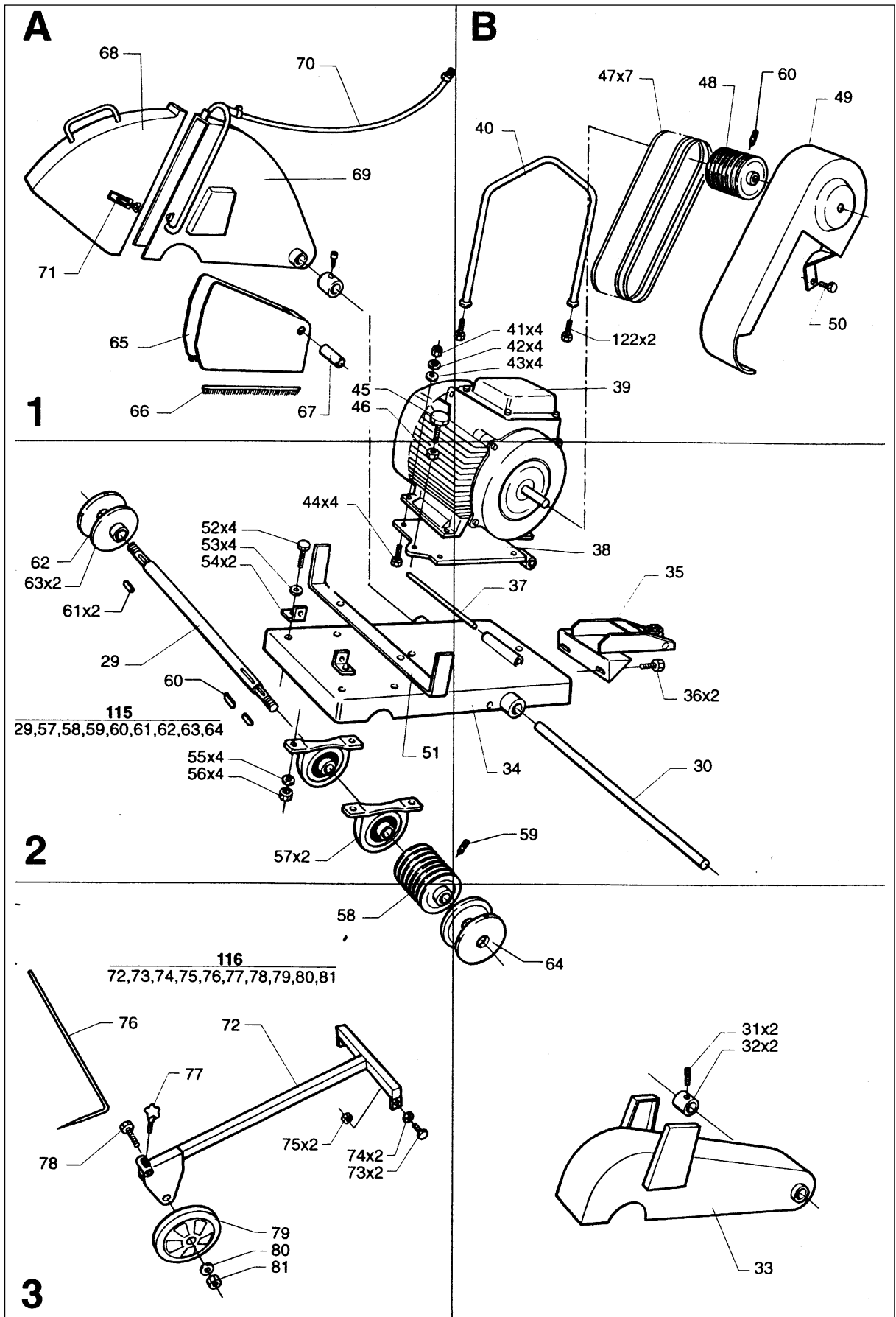

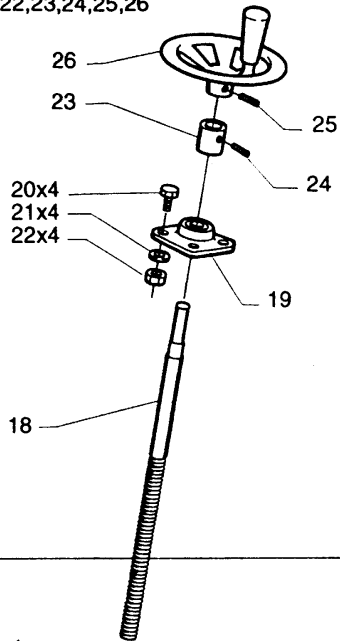
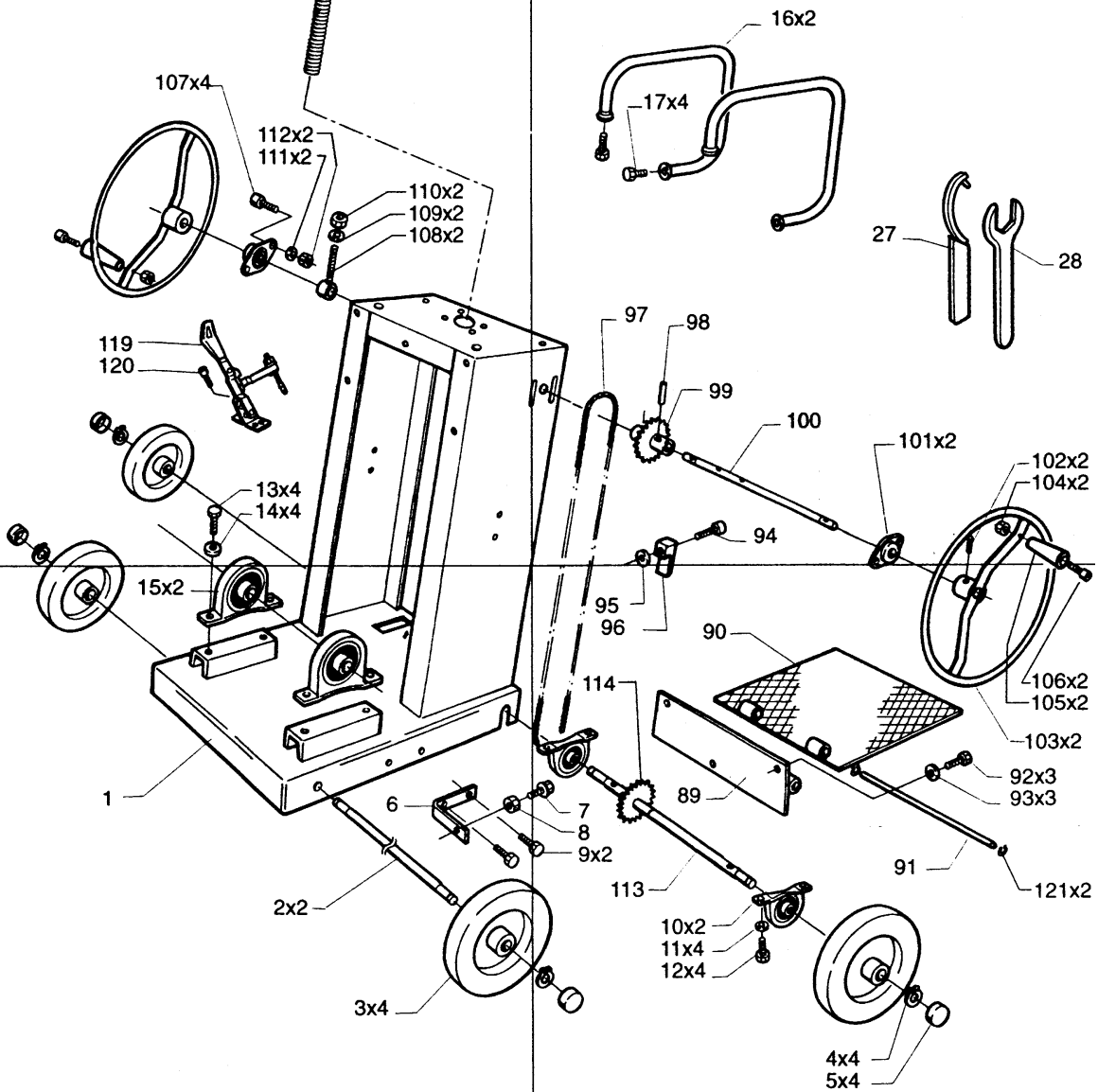
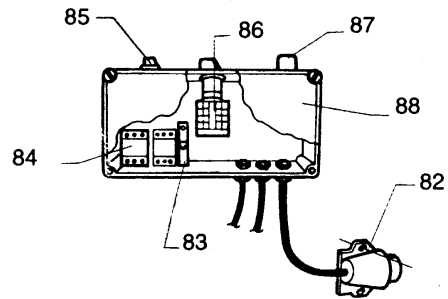
C**117**
18,19,20,21,22,23,24,25,26**D****118**
82,83,84,85,86,87,88



www.husqvarnacp.com

5040596-02

2006-12-12

Free Manuals Download Website

<http://myh66.com>

<http://usermanuals.us>

<http://www.somanuals.com>

<http://www.4manuals.cc>

<http://www.manual-lib.com>

<http://www.404manual.com>

<http://www.luxmanual.com>

<http://aubethermostatmanual.com>

Golf course search by state

<http://golfingnear.com>

Email search by domain

<http://emailbydomain.com>

Auto manuals search

<http://auto.somanuals.com>

TV manuals search

<http://tv.somanuals.com>